

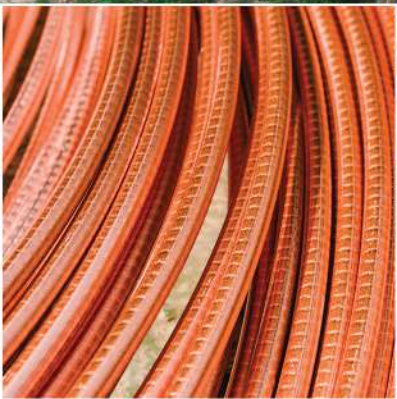

Product Catalogue
**Medium Voltage
Cables**

TRUSTED NOT TO COMPROMISE







Contents

List of Tables	01
Specification & Construction	02
Conductor Data	04
Correction Factors	21
Group Correction Factors	22
Cables installed in single way ducts	23
Group Correction Factors	24
Short Circuit Rating (Copper)	26
Short Circuit Rating (Aluminium)	27
Laying, Handling and Storage	28



List of Tables

TABLE #	TABLE TITLE	PAGE #
01	CONDUCTOR DATA Diameters of stranded circular compacted copper and aluminium conductors	04
02	CONSTRUCTION DETAILS AND ELECTRICAL PARAMETERS 6.35 / 11 kV, Single Core, Copper Conductors, XLPE Insulated to IEC 60502-2, Unarmoured	05
03	6.35 / 11 kV, Single Core, Copper Conductors, XLPE Insulated to IEC 60502-2, Aluminium Wire Armoured	06
04	6.35 / 11 kV, Three Core, Copper Conductors, XLPE Insulated to IEC 60502-2, Unarmoured	07
05	6.35 / 11 kV, Three Core, Copper Conductors, XLPE Insulated to IEC 60502-2, Steel Wire Armoured	08
06	6.35 / 11 kV, Single Core, Aluminium Conductors, XLPE Insulated to IEC 60502-2, Unarmoured	09
07	6.35 / 11 kV, Single Core, Aluminium Conductors, XLPE Insulated to IEC 60502-2, Aluminium Wire Armoured	10
08	6.35 / 11 kV, Three Core, Aluminium Conductors, XLPE Insulated to IEC 60502-2, Unarmoured	11
09	6.35 / 11 kV, Three Core, Aluminium Conductors, XLPE Insulated to IEC 60502-2, Steel Wire Armoured	12
10	8.7 / 15 kV, Single Core, Copper Conductors, XLPE Insulated to IEC 60502-2, Unarmoured	13
11	8.7 / 15 kV, Single Core, Copper Conductors, XLPE Insulated to IEC 60502-2, Aluminium Wire Armoured	14
12	8.7 / 15 kV, Three Core, Copper Conductors, XLPE Insulated to IEC 60502-2, Unarmoured	15
13	8.7 / 15 kV, Three Core, Copper Conductors, XLPE Insulated to IEC 60502-2, Steel Wire Armoured	16
14	8.7 / 15 kV, Single Core, Aluminium Conductors, XLPE Insulated to IEC 60502-2, Unarmoured	17
15	8.7 / 15 kV, Single Core, Aluminium Conductors, XLPE Insulated to, IEC 60502-2, Aluminium Wire Armoured.	18
16	8.7 / 15 kV, Three Core, Aluminium Conductors, XLPE Insulated to IEC 60502-2, Unarmoured	19
17	8.7 / 15 kV, Three Core, Aluminium Conductors, XLPE Insulated to IEC 60502-2, Steel Wire Armoured	20
18	CORRECTION FACTORS Variation in Ground Temperature	21
19	Correction factors for depth of laying	21
20	Correction factors for variation in thermal resistivity of soil	21
21	GROUP CORRECTION FACTORS Group Correction Factors For Circuits of Three Single Core Cables in Trefoil and Laid Flat Touching, Horizontal Formation	22
22	Group Correction Factors For Multicore cables in Horizontal formation	22
23	CABLES INSTALLED IN SINGLE WAY DUCTS Variation in Ground Temperature	23
24	Correction factors for depth of laying	23
25	Correction factors for variation in thermal resistivity of soil	23
26	GROUP CORRECTION FACTORS Group Correction factors for single core cables in trefoil single way ducts, horizontal formation	24
27	Group correction factors for multicore cables in single way ducts, horizontal formation	24
28	Variation in Air Temperature	25

Specification and Construction

Specifications

Medium Voltage XLPE Cables mentioned in this catalogue are rated 6.35 / 11 kV & 8.7 / 15 kV manufactured in accordance with IEC 60502-2, "Cables for rated voltage from 6 kV ($U_m = 7.2$ kV) up to 30 kV ($U_m = 36$ kV)".

Conductors

All Cables are supplied with circular stranded conductors in Copper or Aluminium. These conductors comply with IEC 60228 "Conductors for Insulated Cables".

Conductor Screening

Conductor Screen comprise of an extruded layer of semi-conducting compound applied over the conductor.

Insulation

Pakistan Cables approach to the production of Medium Voltage XLPE Insulated Core is to extrude all the three layers (semi conducting conductor screen, XLPE Insulation and semi conducting core

screen) in one operation through a triple extrusion head. This process is combined with a fully enclosed material handling and drying system ensuring high cleanliness of material and excellent bonding of layers, which is of paramount importance to ensure long term electrical characteristics.

Core Screening

Core Screen comprises of an extruded layer of semi-conducting compound. This layer can be supplied either fully bonded to the insulation or readily strippable.

Metallic Layer

It comprises of a layer of Copper Tape applied over semi-conducting core screen with an overlap and in contact with each other in case of three core cables.

Separation Sheath (Bedding)

All armoured cables have an extruded layer of Black PVC Bedding conforming to type ST2 of IEC 60502-2.



Armouring

The armour of single core cables consists of a layer of Aluminium Wires.

Three core cables are armoured with a layer of galvanized steel wires.

Outer Sheath

Cables are supplied with an extruded Black PVC outer sheath complying with Type ST2 of IEC 60502-2. PCL also offers cables with PVC sheathing having low HCl emission and reduced flame propagation characteristics. LSF PVC Compound have oxygen index of more than 30.

Outer sheath with Anti-termite and Anti Rodent resistance characteristic can also be offered whenever required.

Other sheathing materials such as Polyethylene can also be supplied if required.

Cable Testing

Routine tests carried out on all cable lengths are:

- Spark Test on over sheath
- Conductor Resistance
- High Voltage Test on completed cable
- Partial Discharge Test on completed cable

Type Test Approval

MV Cable manufactured by Pakistan Cables have been fully type tested in accordance with IEC 60502-2 at prestigious High Voltage & Short Circuit Labs at Rawat, Pakistan.

Conductor Data

Diameters of stranded circular compacted copper and aluminium conductors

Table 1

Cross-sectional Area mm ²	Minimum diameter mm	Maximum diameter mm
25	5.6	6.5
35	6.6	7.5
50	7.7	8.6
70	9.3	10.2
95	11.0	12.0
120	12.3	13.5
150	13.7	15.0
185	15.3	16.8
240	17.6	19.2
300	19.7	21.6



6.35 / 11 kV
 Single Core
 Copper Conductors
 XLPE Insulated to
 IEC 60502-2
 Unarmoured

1. Copper conductor
2. Semiconductive conductor screen
3. XLPE insulation
4. Semiconductive insulation screen
5. Copper tape screen
6. Outer sheath

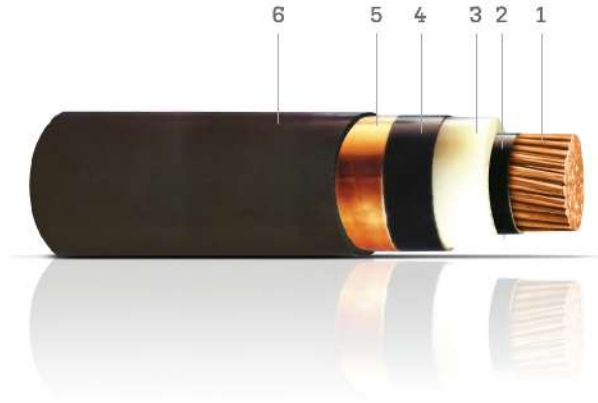

Table 2

Constructional Details:												
Nominal Area of Conductor	mm ²	50	70	95	120	150	185	240	300	400	500	630
Insulation Thickness (Nominal)	mm	3.4	3.4	3.4	3.4	3.4	3.4	3.4	3.4	3.4	3.4	3.4
Outersheath Thickness (Nominal)	mm	1.6	1.7	1.7	1.8	1.8	1.9	2.0	2.0	2.1	2.2	2.3
Approximate Overall Diameter	mm	22.0	23.5	25.5	27.0	28.5	30.0	32.5	35.0	40.0	43.5	47.5
Approximate Cable Weight	Kg/Km	834	1081	1380	1646	1947	2337	2965	3612	4488	5525	7003
Minimum Bending Radius of Cable (during installation)	mm	434	466	502	530	564	598	648	694	800	870	950

Electrical Parameters:												
Maximum DC resistance of Conductor at 20°C	ohm/Km	0.387	0.268	0.193	0.153	0.124	0.0991	0.0754	0.0601	0.047	0.0366	0.0283
Approximate AC resistance of Conductor at 90°C	ohm/Km	0.494	0.342	0.247	0.196	0.159	0.128	0.098	0.079	0.063	0.05	0.041
Approximate Reactance at 50 Hertz	ohm/Km	0.13	0.12	0.11	0.11	0.11	0.1	0.1	0.1	0.09	0.09	0.09
Approximate Capacitance of Cable	µf/Km	0.25	0.29	0.35	0.38	0.41	0.47	0.51	0.54	0.58	0.66	0.74
Continuous Current Ratings												
1. Laid Direct, Ground Temp. 30°C & g = 1.2°C m/W, depth of laying = 0.8m, laid singly	A	196	240	285	320	365	409	472	534	605	668	739
2. Drawn into Ducts, Ground Temp. 30°C & g=1.2°C m/W, depth of laying = 0.8m, laid singly	A	200	240	285	320	356	392	449	498	543	605	668
3. Laid singly in Air, Ambient temp.35°C	A	217	262	331	382	432	497	589	681	773	865	1021
One second Short Circuit Current Rating of Conductor	kA	7.15	10.01	13.60	17.20	21.50	26.50	34.30	42.90	57.20	71.50	90.10

6.35 /11 kV
Single Core
Copper Conductors
XLPE Insulated to
IEC 60502-2
Aluminium Wire
Armoured

1. Copper conductor
2. Semiconductive conductor screen
3. XLPE insulation
4. Semiconductive insulation screen
5. Copper tape screen
6. Bedding
7. Aluminium wire armour
8. Outer sheath



Table 3

Constructional Details:												
Nominal Area of Conductor	mm ²	50	70	95	120	150	185	240	300	400	500	630
Insulation Thickness (Nominal)	mm	3.4	3.4	3.4	3.4	3.4	3.4	3.4	3.4	3.4	3.4	3.4
Separation Sheath Thickness	mm	1.2	1.2	1.2	1.2	1.2	1.2	1.2	1.2	1.2	1.3	1.4
Armour Wire Diameter (Nominal)	mm	1.6	1.6	1.6	1.6	1.6	2	2	2	2	2.5	2.5
Outersheath Thickness (Nominal)	mm	1.8	1.8	1.9	1.9	2	2	2.1	2.2	2.3	2.5	2.6
Approximate Overall Diameter	mm	28	29.5	31.5	33	35.5	37	39.5	41.5	46.5	49.5	53
Approximate Cable Weight	Kg/Km	1261	1540	1873	2247	2580	3001	3687	4382	5483	6590	8200
Minimum Bending Radius of Cable (during installation)	mm	416	440	467	489	527	552	568	623	692	738	792

Electrical Parameters:												
Maximum DC resistance of Conductor at 20°C	ohm/Km	0.387	0.268	0.193	0.153	0.124	0.0991	0.0754	0.0601	0.047	0.0366	0.0283
Approximate AC resistance of Conductor at 90°C	ohm/Km	0.493	0.342	0.246	0.196	0.16	0.127	0.098	0.079	0.063	0.05	0.041
Approximate Reactance at 50 Hertz	ohm/Km	0.14	0.13	0.12	0.12	0.12	0.11	0.11	0.10	0.10	0.10	0.10
Approximate Capacitance of Cable	µf/Km	0.25	0.29	0.35	0.38	0.41	0.47	0.51	0.54	0.58	0.66	0.74
Continuous Current Ratings												
1. Laid Direct, Ground Temp. 30°C & g = 1.2°C m/W, depth of laying = 0.8m, laid in trefoil touching	A	196	240	285	320	365	405	463	516	579	632	676
2. Drawn into Ducts, Ground Temp. 30°C & g = 1.2°C m/W, depth of laying = 0.8m, laid singly	A	196	231	271	303	334	365	418	445	472	507	552
3. Laid in Air in trefoil touching, Ambient Temp. 35°C	A	230	285	345	396	451	506	598	681	773	856	957
One second Short Circuit Current Rating of Conductor	kA	7.15	10.01	13.6	17.2	21.5	26.5	34.3	42.9	57.2	71.5	90.1



6.35 /11 kV
 Three Core
 Copper Conductors
 XLPE Insulated to
 IEC 60502-2
 Unarmoured

1. Copper conductor
2. Semiconductive conductor screen
3. XLPE insulation
4. Semiconductive insulation screen
5. Copper tape screen
6. Fillers
7. Tape binder
8. Outer sheath

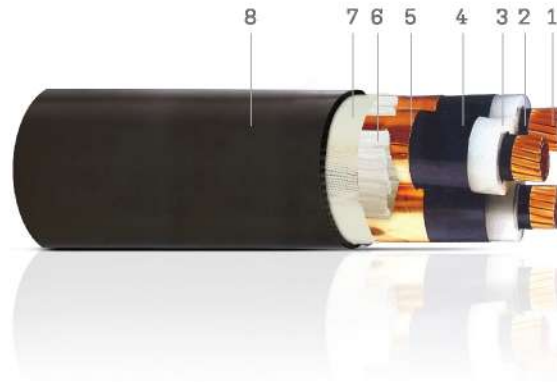

Table 4

Constructional Details:											
Nominal Area of Conductor	mm ²	25	35	50	70	95	120	150	185	240	300
Insulation Thickness (Nominal)	mm	3.4	3.4	3.4	3.4	3.4	3.4	3.4	3.4	3.4	3.4
Outersheath Thickness (Nominal)	mm	2.2	2.3	2.4	2.5	2.6	2.7	2.8	2.9	3.1	3.2
Approximate Overall Diameter	mm	37	40	45	48.5	52.5	55.5	59	62.5	68	73
Approximate Cable Weight	Kg/Km	1883	2284	2769	3557	4513	5398	6354	7666	9670	11765
Minimum Bending Radius of Cable (during installation)	mm	560	600	671	726	782	831	882	938	1017	1094

Electrical Parameters:											
Maximum DC resistance of Conductor at 20°C	ohm/Km	0.727	0.524	0.387	0.268	0.193	0.153	0.124	0.0991	0.0754	0.0601
Approximate AC resistance of Conductor at 90°C	ohm/Km	0.927	0.668	0.493	0.342	0.247	0.196	0.159	0.128	0.098	0.08
Approximate Reactance at 50 Hertz	ohm/Km	0.12	0.11	0.11	0.11	0.1	0.1	0.09	0.09	0.09	0.09
Approximate Capacitance of Cable	µf/Km	0.22	0.24	0.25	0.29	0.35	0.38	0.41	0.47	0.51	0.54
Continuous Current Ratings											
1. Laid Direct, Ground Temp. 30°C & g =1.2°C m/W, depth of laying = 0.8m, laid singly	A	138	169	198	241	283	321	358	406	462	510
2. Drawn into Ducts, Ground Temp. 30°C & g =1.2°C m/W, depth of laying = 0.8m, laid singly	A	122	143	170	202	241	273	312	349	401	443
3. Laid singly in Air, Ambient temp. 35°C	A	145	171	210	258	316	359	412	469	545	622
One Second Short Circuit Current Rating of Conductor	kA	3.6	5.0	7.15	10.01	13.6	17.2	21.5	26.5	34.3	42.9

**6.35 /11 kV
Three Core
Copper Conductors
XLPE Insulated to
IEC 60502-2
Steel Wire Armoured**

1. Copper conductor
2. Semiconductive conductor screen
3. XLPE insulation
4. Semiconductive insulation screen
5. Copper tape screen
6. Fillers
7. Tape binder
8. Bedding
9. Galvanised steel wire armour
10. Outer sheath

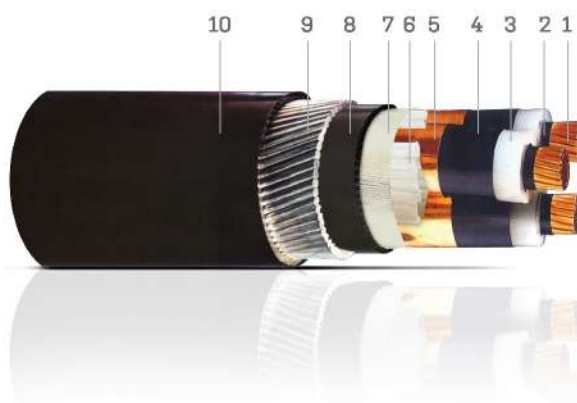

Table 5

Constructional Details:											
Nominal Area of Conductor	mm ²	25	35	50	70	95	120	150	185	240	300
Insulation Thickness (Nominal)	mm	3.4	3.4	3.4	3.4	3.4	3.4	3.4	3.4	3.4	3.4
Separation Sheath Thickness	mm	1.3	1.3	1.4	1.4	1.5	1.6	1.6	1.7	1.8	1.9
Armour Wire Diameter (Nominal)	mm	2.5	2.5	2.5	2.5	2.5	2.5	2.5	2.5	3.15	3.15
Outersheath Thickness (Nominal)	mm	2.5	2.5	2.6	2.7	2.9	3	3.1	3.2	3.4	3.6
Approximate Overall Diameter	mm	48	50.5	53	56.5	61	64	67.5	71.5	79	83.5
Approximate Cable Weight	Kg/Km	4350	4950	5250	6250	7350	8500	9550	11000	14250	16600
Minimum Bending Radius of Cable (during installation)	mm	580	610	636	678	727	768	810	857	940	1002

Electrical Parameters:											
Maximum DC resistance of Conductor at 20°C	ohm/Km	0.727	0.524	0.387	0.268	0.193	0.153	0.124	0.0991	0.0754	0.0601
Approximate AC resistance of Conductor at 90°C	ohm/Km	0.927	0.668	0.493	0.342	0.247	0.196	0.159	0.128	0.098	0.078
Approximate Reactance at 50 Hertz	ohm/Km	0.12	0.11	0.11	0.11	0.10	0.10	0.09	0.09	0.09	0.09
Approximate Capacitance of Cable	µf/Km	0.22	0.24	0.25	0.29	0.35	0.38	0.41	0.47	0.51	0.54
Continuous Current Ratings											
1. Laid Direct, Ground Temp. 30°C & g = 1.2°C m/W, depth of laying = 0.8m, laid singly	A	130	160	187	227	267	303	338	383	436	481
2. Drawn into Ducts, Ground Temp. 30°C & g=1.2°C m/W, depth of laying = 0.8m, laid singly	A	115	135	161	191	227	258	294	329	378	418
3. Laid singly in Air, Ambient temp.35°C	A	140	165	203	248	304	345	396	451	524	598
One second Short Circuit Current Rating of Conductor	kA	3.6	5.0	7.15	10.01	13.60	17.20	21.50	26.5	34.3	42.9

6.35 / 11 kV
Single Core
Aluminium Conductors
XLPE Insulated to
IEC 60502-2
Unarmoured

1. Aluminium conductor
2. Semiconductive conductor screen
3. XLPE insulation
4. Semiconductive insulation screen
5. Copper tape screen
6. Outer sheath

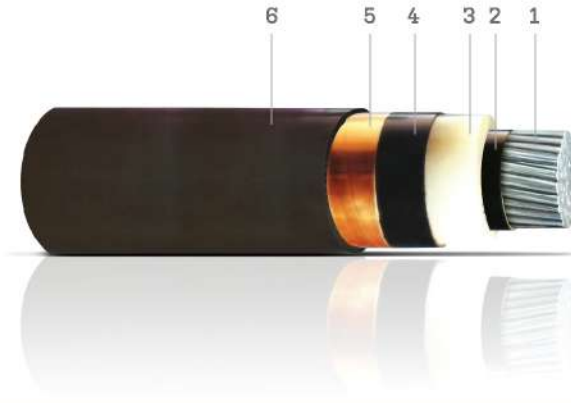
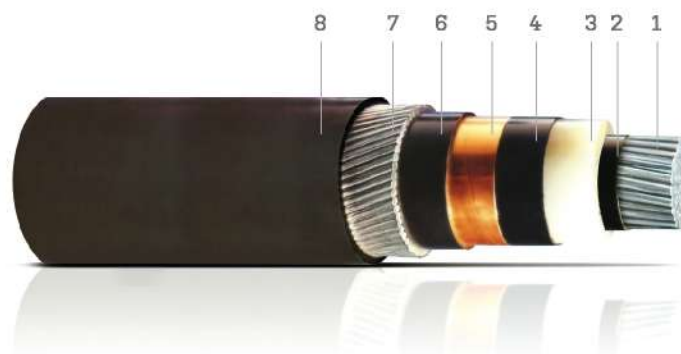

Table 6

Constructional Details:												
Nominal Area of Conductor	mm ²	50	70	95	120	150	185	240	300	400	500	630
Insulation Thickness (Nominal)	mm	3.4	3.4	3.4	3.4	3.4	3.4	3.4	3.4	3.4	3.4	3.4
Outersheath Thickness (Nominal)	mm	1.6	1.7	1.7	1.8	1.8	1.9	2.0	2.0	2.1	2.2	2.3
Approximate Overall Diameter	mm	22.0	23.5	25.5	27.0	28.5	30.0	32.5	35.0	40.0	43.5	47.5
Approximate Cable Weight	Kg/Km	536	649	782	890	1019	1172	1419	1673	2008	2399	2947
Minimum Bending Radius of Cable (during installation)	mm	434	466	502	530	564	598	648	694	800	870	950

Electrical Parameters:												
Maximum DC resistance of Conductor at 20°C	ohm/Km	0.641	0.443	0.320	0.253	0.206	0.164	0.125	0.100	0.0778	0.0605	0.0469
Approximate AC resistance of Conductor at 90°C	ohm/Km	0.822	0.568	0.411	0.325	0.265	0.211	0.162	0.13	0.102	0.08	0.064
Approximate Reactance at 50 Hertz	ohm/Km	0.13	0.12	0.11	0.11	0.11	0.10	0.10	0.10	0.09	0.09	0.09
Approximate Capacitance of Cable	µf/Km	0.25	0.29	0.35	0.38	0.41	0.47	0.51	0.54	0.58	0.66	0.74
Continuous Current Ratings												
1. Laid Direct, Ground Temp. 30°C & g = 1.2°C m/W, depth of laying = 0.8m, laid singly	A	151	187	223	249	285	320	369	423	481	543	605
2. Drawn into Ducts, Ground Temp. 30°C & g=1.2°C m/W, depth of laying = 0.8m, laid singly	A	156	191	227	254	280	312	360	405	454	507	570
3. Laid singly in Air, Ambient temp.35°C	A	166	207	258	294	336	391	460	534	616	727	837
One second Short Circuit Current Rating of Conductor	kA	4.70	6.58	8.93	11.28	14.10	17.30	22.56	28.20	37.60	47.00	59.22

6.35 /11 kV
Single Core
Aluminium Conductors
XLPE Insulated to
IEC 60502-2
Aluminium Wire
Armoured



1. Aluminium conductor
2. Semiconductive conductor screen
3. XLPE insulation
4. Semiconductive insulation screen
5. Copper tape screen
6. Bedding
7. Aluminium wire armour
8. Outer sheath

Table 7

Constructional Details:												
Nominal Area of Conductor	mm ²	50	70	95	120	150	185	240	300	400	500	630
Insulation Thickness (Nominal)	mm	3.4	3.4	3.4	3.4	3.4	3.4	3.4	3.4	3.4	3.4	3.4
Separation Sheath Thickness	mm	1.2	1.2	1.2	1.2	1.2	1.2	1.2	1.2	1.3	1.3	1.4
Armour Wire Diameter (Nominal)	mm	1.6	1.6	1.6	1.6	2	2	2	2	2.5	2.5	2.5
Outersheath Thickness (Nominal)	mm	1.8	1.9	1.9	2	2.1	2.1	2.2	2.3	2.4	2.5	2.6
Approximate Overall Diameter	mm	28	29.5	31.5	33	35.5	37	39.5	41.5	46.5	49.5	53
Approximate Cable Weight	Kg/Km	962	1109	1275	1491	1652	1836	2141	2443	3003	3463	4144
Minimum Bending Radius of Cable (during installation)	mm	416	440	467	489	527	552	588	623	692	738	792

Electrical Parameters:												
Maximum DC resistance of Conductor at 20°C	ohm/Km	0.641	0.443	0.32	0.253	0.206	0.164	0.125	0.100	0.0778	0.0605	0.0469
Approximate AC resistance of Conductor at 90°C	ohm/Km	0.822	0.568	0.411	0.325	0.265	0.211	0.162	0.13	0.102	0.080	0.064
Approximate Reactance at 50 Hertz	ohm/Km	0.14	0.13	0.12	0.12	0.12	0.11	0.11	0.10	0.10	0.10	0.10
Approximate Capacitance of Cable	µf/Km	0.25	0.29	0.35	0.38	0.41	0.47	0.51	0.54	0.58	0.66	0.74
Continuous Current Ratings												
1. Laid Direct, Ground Temp. 30°C & g = 1.2°C m/W, depth of laying = 0.8m, laid in trefoil touching	A	151	187	223	249	280	316	360	405	454	507	570
2. Drawn into Ducts, Ground Temp. 30°C & g=1.2°C m/W, depth of laying = 0.8m, laid singly	A	151	187	218	245	267	298	338	374	405	445	490
3. Laid in Air in trefoil touching, Ambient Temp. 35°C	A	179	221	271	327	350	400	469	534	616	708	810
One second Short Circuit Current Rating of Conductor	kA	4.7	6.58	8.93	11.28	14.1	17.39	22.56	28.20	37.60	47.00	59.22

6.35 /11 kV
 Three Core
 Aluminium Conductors
 XLPE Insulated to
 IEC 60502-2
 Unarmoured

1. Aluminium conductor
2. Semiconductive conductor screen
3. XLPE insulation
4. Semiconductive insulation screen
5. Copper tape screen
6. Fillers
7. Tape binder
8. Outer sheath

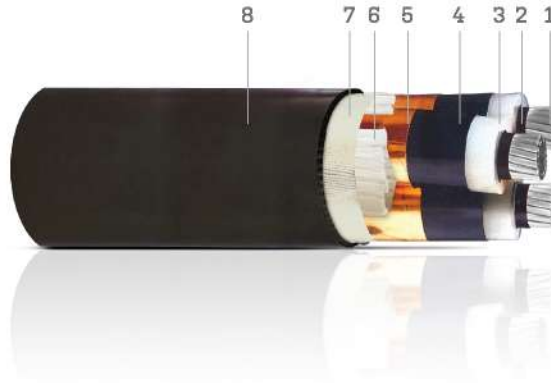
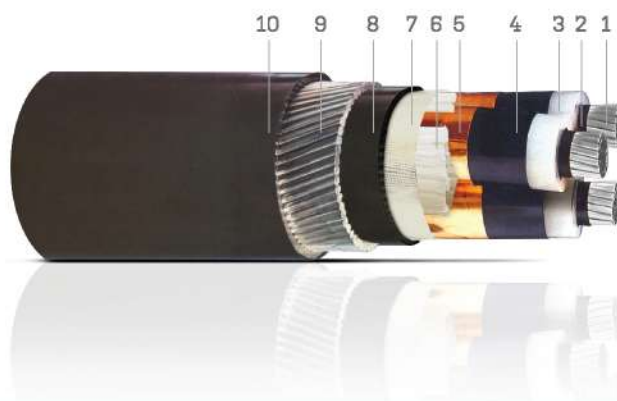

Table 8

Constructional Details:											
Nominal Area of Conductor	mm ²	25	35	50	70	95	120	150	185	240	300
Insulation Thickness (Nominal)	mm	3.4	3.4	3.4	3.4	3.4	3.4	3.4	3.4	3.4	3.4
Outersheath Thickness (Nominal)	mm	2.2	2.3	2.4	2.5	2.6	2.7	2.8	2.9	3.1	3.2
Approximate Overall Diameter	mm	37	40	45	48.5	52.5	55.5	59	62.5	68	73
Approximate Cable Weight	Kg/Km	1397	1609	1856	2237	2683	3085	3513	4102	4941	5833
Minimum Bending Radius of Cable (during installation)	mm	560	600	671	723	782	831	882	938	1017	1094

Electrical Parameters:											
Maximum DC resistance of Conductor at 20°C	ohm/Km	1.2	0.868	0.641	0.443	0.32	0.253	0.206	0.164	0.125	0.1
Approximate AC resistance of Conductor at 90°C	ohm/Km	1.54	1.11	0.822	0.568	0.41	0.325	0.265	0.211	0.161	0.13
Approximate Reactance at 50 Hertz	ohm/Km	0.12	0.11	0.11	0.11	0.1	0.1	0.09	0.09	0.09	0.09
Approximate Capacitance of Cable	µf/Km	0.22	0.24	0.25	0.29	0.35	0.38	0.41	0.47	0.51	0.54
Continuous Current Ratings											
1. Laid Direct, Ground Temp. 30°C & g = 1.2°C m/W, depth of laying = 0.8m, laid singly	A	127	148	151	184	217	250	283	316	358	410
2. Drawn into Ducts, Ground Temp. 30°C & g = 1.2°C m/W, depth of laying = 0.8m, laid singly	A	106	127	127	156	189	212	241	274	316	354
3. Laid singly in Air, Ambient temp. 35°C	A	130	156	163	201	239	282	316	368	431	488
One Second Short Circuit Current Rating of Conductor	kA	2.3	3.2	4.7	6.58	8.93	11.3	14.1	17.4	22.6	28.2

**6.35 /11 kV
Three Core
Aluminium Conductors
XLPE Insulated to
IEC 60502-2
Steel Wire Armoured**



1. Aluminium conductor
2. Semiconductive conductor screen
3. XLPE insulation
4. Semiconductive insulation screen
5. Copper tape screen
6. Fillers
7. Tape binder
8. Bedding
9. Galvanised steel wire armour
10. Outer sheath

Table 9

Constructional Details:											
Nominal Area of Conductor	mm ²	25	35	50	70	95	120	150	185	240	300
Insulation Thickness (Nominal)	mm	3.4	3.4	3.4	3.4	3.4	3.4	3.4	3.4	3.4	3.4
Separation Sheath Thickness	mm	1.3	1.3	1.4	1.4	1.5	1.6	1.6	1.7	1.8	1.9
Armour Wire Diameter (Nominal)	mm	2.5	2.5	2.5	2.5	2.5	2.5	2.5	2.5	3.15	3.15
Outersheath Thickness (Nominal)	mm	2.5	2.6	2.6	2.7	2.9	3	3.1	3.2	3.4	3.6
Approximate Overall Diameter	mm	48.0	50.5	53	56.5	61	64	67.5	71.5	78.5	83.5
Approximate Cable Weight	Kg/Km	3970	4300	4350	4960	5360	6240	6780	7520	9670	10860
Minimum Bending Radius of Cable (during installation)	mm	580	610	636	678	727	768	810	857	940	1002

Electrical Parameters:											
Maximum DC resistance of Conductor at 20°C	ohm/Km	1.20	0.868	0.641	0.443	0.32	0.253	0.206	0.164	0.125	0.1
Approximate AC resistance of Conductor at 90°C	ohm/Km	1.54	1.11	0.822	0.568	0.411	0.325	0.265	0.211	0.162	0.13
Approximate Reactance at 50 Hertz	ohm/Km	0.12	0.11	0.11	0.11	0.10	0.10	0.09	0.09	0.09	0.09
Approximate Capacitance of Cable	µf/Km	0.22	0.24	0.25	0.29	0.35	0.38	0.41	0.47	0.51	0.54
Continuous Current Ratings											
1. Laid Direct, Ground Temp. 30°C & g = 1.2°C m/W, depth of laying = 0.8m, laid singly	A	120	140	142	174	205	236	267	298	338	387
2. Drawn into Ducts, Ground Temp. 30°C & g=1.2°C m/W, depth of laying = 0.8m, laid singly	A	100	120	120	147	178	200	227	258	298	334
3. Laid in Air singly, Ambient Temp. 35°C	A	125	150	156	193	230	271	304	354	414	469
One second Short Circuit Current Rating of Conductor	kA	2.3	3.2	4.7	6.58	8.93	11.28	14.1	17.39	22.56	28.2

8.7 / 15 kV
Single Core
Copper Conductors
XLPE Insulated to
IEC 60502-2
Unarmoured

1. Copper conductor
2. Semiconductive conductor screen
3. XLPE insulation
4. Semiconductive insulation screen
5. Copper tape screen
6. Outer sheath

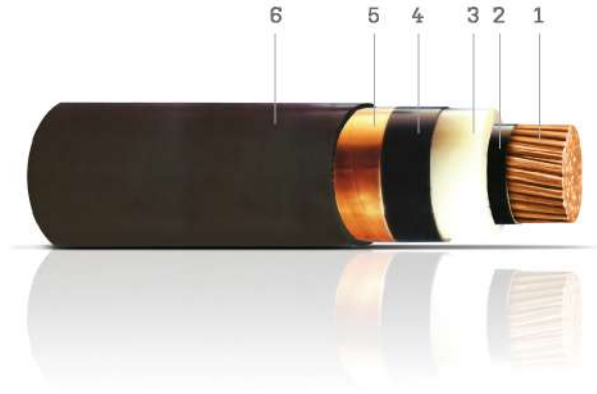

Table 10

Constructional Details:												
Nominal Area of Conductor	mm ²	50	70	95	120	150	185	240	300	400	500	630
Insulation Thickness (Nominal)	mm	4.5	4.5	4.5	4.5	4.5	4.5	4.5	4.5	4.5	4.5	4.5
Outersheath Thickness (Nominal)	mm	1.8	1.8	1.8	1.9	1.9	2.0	2.0	2.1	2.2	2.3	2.4
Approximate Overall Diameter	mm	24.5	26.0	27.5	29.0	31.0	32.5	35.0	37.5	42.5	46.0	50.0
Approximate Cable Weight	Kg/Km	931	1184	1479	1763	2056	2466	3104	3742	4629	5676	7168
Minimum Bending Radius of Cable (during installation)	mm	482	514	550	580	612	645	696	742	850	920	1000

Electrical Parameters:												
Maximum DC resistance of Conductor at 20°C	ohm/Km	0.387	0.268	0.193	0.153	0.124	0.0991	0.0754	0.0601	0.047	0.0366	0.0283
Approximate AC resistance of Conductor at 90°C	ohm/Km	0.494	0.342	0.247	0.196	0.159	0.128	0.098	0.079	0.063	0.05	0.041
Approximate Reactance at 50 Hertz	ohm/Km	0.13	0.13	0.12	0.11	0.11	0.11	0.10	0.10	0.10	0.09	0.09
Approximate Capacitance of Cable	µf/Km	0.22	0.25	0.28	0.31	0.33	0.36	0.41	0.44	0.49	0.54	0.59
Continuous Current Ratings												
1. Laid Direct, Ground Temp. 30°C & g =1.2°C m/W, depth of laying = 0.8m, laid singly	A	196	240	285	320	365	409	472	534	605	668	739
2. Drawn into Ducts, Ground Temp. 30°C & g =1.2°C m/W, depth of laying = 0.8m, laid singly	A	200	240	285	320	356	392	449	498	543	605	668
3. Laid singly in Air, Ambient temp. 35°C	A	217	262	331	382	432	497	589	681	773	865	1021
One Second Short Circuit Current Rating of Conductor	kA	7.15	10.01	13.60	17.20	21.50	26.50	34.30	42.90	57.20	71.50	90.10

8.7 /15 kV
Single Core
Copper Conductors
XLPE Insulated to
IEC 60502-2
Aluminium Wire
Armoured

1. Copper conductor
2. Semiconductive conductor screen
3. XLPE insulation
4. Semiconductive insulation screen
5. Copper tape screen
6. Bedding
7. Aluminium wire armour
8. Outer sheath

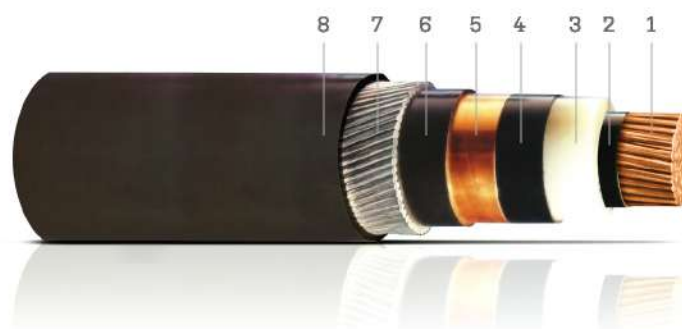

Table 11

Constructional Details:												
Nominal Area of Conductor	mm ²	50	70	95	120	150	185	240	300	400	500	630
Insulation Thickness (Nominal)	mm	4.5	4.5	4.5	4.5	4.5	4.5	4.5	4.5	4.5	4.5	4.5
Separation Sheath Thickness	mm	1.2	1.2	1.2	1.2	1.2	1.2	1.2	1.2	1.3	1.3	1.4
Armour Wire Diameter (Nominal)	mm	1.6	1.6	2.0	2.0	2.0	2.0	2.0	2.0	2.5	2.5	2.5
Outersheath Thickness (Nominal)	mm	1.9	2.0	2.0	2.1	2.1	2.2	2.3	2.3	2.5	2.6	2.7
Approximate Overall Diameter	mm	30.5	32	34.5	36	37.5	39.5	42	44	48.5	52	55.5
Approximate Cable Weight	Kg/Km	1401	1688	2111	2412	2752	3188	3875	4579	5709	6849	8456
Minimum Bending Radius of Cable (during installation)	mm	452	476	515	537	561	587	624	660	728	776	828

Electrical Parameters:												
Maximum DC resistance of Conductor at 20°C	ohm/Km	0.387	0.268	0.193	0.153	0.124	0.0991	0.0754	0.0601	0.047	0.0366	0.0283
Approximate AC resistance of Conductor at 90°C	ohm/Km	0.494	0.342	0.247	0.196	0.159	0.127	0.098	0.078	0.063	0.050	0.041
Approximate Reactance at 50 Hertz	ohm/Km	0.14	0.14	0.13	0.12	0.12	0.12	0.11	0.11	0.11	0.10	0.10
Approximate Capacitance of Cable	µf/Km	0.22	0.25	0.28	0.31	0.33	0.36	0.41	0.44	0.49	0.54	0.59
Continuous Current Ratings												
1. Laid Direct, Ground Temp. 30°C & g = 1.2°C m/W, depth of laying = 0.8m, laid in trefoil touching	A	196	240	285	320	365	405	463	516	579	632	676
2. Drawn into Ducts, Ground Temp. 30°C & g = 1.2°C m/W, depth of laying = 0.8m, laid singly	A	196	231	271	303	334	365	418	445	472	507	552
3. Laid in Air in trefoil touching, Ambient Temp. 35°C	A	230	285	345	396	451	506	598	681	773	856	957
One second Short Circuit Current Rating of Conductor	kA	7.15	10.01	13.6	17.2	21.5	26.5	34.3	42.9	57.2	71.5	90.1

8.7 / 15 kV
 Three Core
 Copper Conductors
 XLPE Insulated to
 IEC 60502-2
 Unarmoured

1. Copper conductor
2. Semiconductive conductor screen
3. XLPE insulation
4. Semiconductive insulation screen
5. Copper tape screen
6. Fillers
7. Tape binder
8. Outer sheath

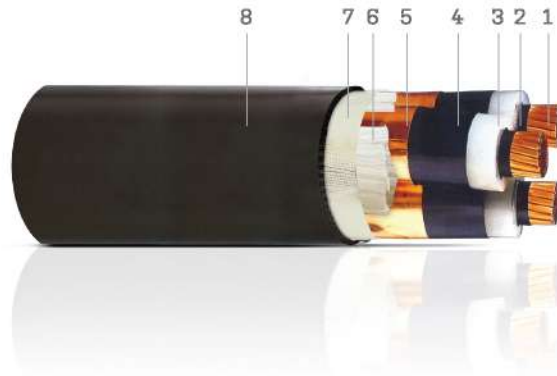
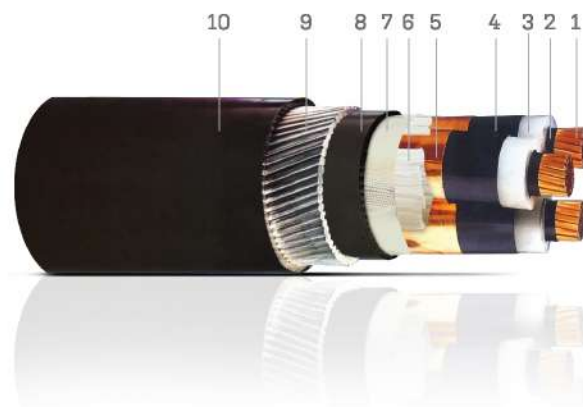

Table 12

Constructional Details:											
Nominal Area of Conductor	mm ²	25	35	50	70	95	120	150	185	240	300
Insulation Thickness (Nominal)	mm	4.5	4.5	4.5	4.5	4.5	4.5	4.5	4.5	4.5	4.5
Outersheath Thickness (Nominal)	mm	2.4	2.5	2.5	2.6	2.8	2.9	3	3.1	3.2	3.4
Approximate Overall Diameter	mm	43	45	50	53.5	57.5	60.5	64	68	73	78
Approximate Cable Weight	Kg/Km	2213	2633	3137	3953	4937	5845	6826	8137	10212	12308
Minimum Bending Radius of Cable (during installation)	mm	650	680	749	800	858	908	959	1014	1094	1170

Electrical Parameters:											
Maximum DC resistance of Conductor at 20°C	ohm/Km	0.727	0.524	0.387	0.268	0.193	0.153	0.124	0.0991	0.0754	0.0601
Approximate AC resistance of Conductor at 90°C	ohm/Km	0.927	0.668	0.493	0.342	0.247	0.196	0.159	0.128	0.098	0.079
Approximate Reactance at 50 Hertz	ohm/Km	0.13	0.12	0.12	0.11	0.11	0.1	0.1	0.1	0.09	0.09
Approximate Capacitance of Cable	µf/Km	0.19	0.21	0.22	0.25	0.28	0.31	0.33	0.36	0.41	0.44
Continuous Current Ratings											
1. Laid Direct, Ground Temp. 30°C & g = 1.2°C m/W, depth of laying = 0.8m, laid singly	A	138	169	198	241	283	321	358	406	462	510
2. Drawn into Ducts, Ground Temp. 30°C & g = 1.2°C m/W, depth of laying = 0.8m, laid singly	A	122	143	170	202	241	273	312	349	401	443
3. Laid singly in Air, Ambient temp. 35°C	A	145	171	210	258	316	359	412	469	545	622
One Second Short Circuit Current Rating of Conductor	kA	3.6	5.00	7.15	10.01	13.6	17.2	21.5	26.5	34.3	42.9

**8.7 /15 kV
Three Core
Copper Conductors
XLPE Insulated to
IEC 60502-2
Steel Wire Armoured**



1. Copper conductor
2. Semiconductive conductor screen
3. XLPE insulation
4. Semiconductive insulation screen
5. Copper tape screen
6. Fillers
7. Tape binder
8. Bedding
9. Galvanised steel wire armour
10. Outer sheath

Table 13

Constructional Details:											
Nominal Area of Conductor	mm ²	25	35	50	70	95	120	150	185	240	300
Insulation Thickness (Nominal)	mm	4.5	4.5	4.5	4.5	4.5	4.5	4.5	4.5	4.5	4.5
Separation Sheath Thickness	mm	1.4	1.4	1.5	1.5	1.6	1.7	1.7	1.8	1.9	2.0
Armour Wire Diameter (Nominal)	mm	2.5	2.5	2.5	2.5	2.5	2.5	2.5	3.15	3.15	3.15
Outersheath Thickness (Nominal)	mm	2.6	2.7	2.8	2.9	3	3.2	3.3	3.4	3.6	3.8
Approximate Overall Diameter	mm	53	56	58.5	62	66	69.5	73	78	84	89
Approximate Cable Weight	Kg/Km	4740	5269	5950	6950	8150	9150	11190	12750	15000	17450
Minimum Bending Radius of Cable (during installation)	mm	640	680	698	742	791	832	874	936	1003	1066

Electrical Parameters:											
Maximum DC resistance of Conductor at 20°C	ohm/Km	0.727	0.524	0.387	0.268	0.193	0.153	0.124	0.0991	0.0754	0.0601
Approximate AC resistance of Conductor at 90°C	ohm/Km	0.927	0.668	0.493	0.342	0.247	0.196	0.159	0.128	0.098	0.079
Approximate Reactance at 50 Hertz	ohm/Km	0.13	0.12	0.12	0.11	0.11	0.10	0.10	0.10	0.09	0.09
Approximate Capacitance of Cable	µf/Km	0.18	0.20	0.22	0.25	0.28	0.31	0.33	0.36	0.41	0.44
Continuous Current Ratings											
1. Laid Direct, Ground Temp. 30°C & g = 1.2°C m/W, depth of laying = 0.8m, laid singly	A	130	160	187	227	267	303	338	383	436	481
2. Drawn into Ducts, Ground Temp. 30°C & g=1.2°C m/W, depth of laying = 0.8m, laid singly	A	115	135	161	191	227	258	294	329	378	418
3. Laid singly in Air, Ambient temp.35°C	A	140	165	203	248	304	345	396	451	524	598
One second Short Circuit Current Rating of Conductor	kA	3.6	5.0	7.15	10.01	13.60	17.20	21.50	26.5	34.3	42.9

8.7 / 15 kV
Single Core
Aluminium Conductors
XLPE Insulated to
IEC 60502-2
Unarmoured

1. Aluminium conductor
2. Semiconductive conductor screen
3. XLPE insulation
4. Semiconductive insulation screen
5. Copper tape screen
6. Outer sheath

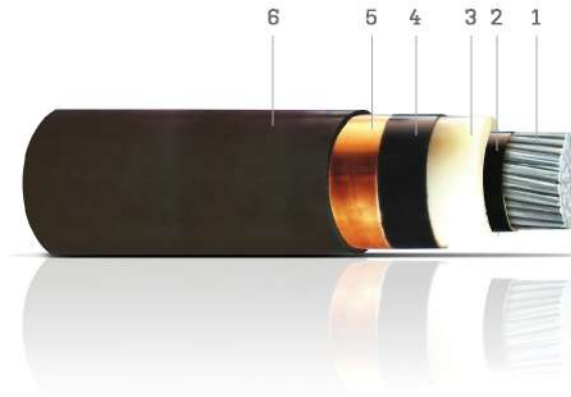

Table 14

Constructional Details:												
Nominal Area of Conductor	mm ²	50	70	95	120	150	185	240	300	400	500	630
Insulation Thickness (Nominal)	mm	4.5	4.5	4.5	4.5	4.5	4.5	4.5	4.5	4.5	4.5	4.5
Outersheath Thickness (Nominal)	mm	1.8	1.8	1.8	1.9	1.9	2.0	2.0	2.1	2.2	2.3	2.4
Approximate Overall Diameter	mm	24.5	26.0	27.5	29.0	31.0	32.5	35.0	37.5	42.5	46.0	50.0
Approximate Cable Weight	Kg/Km	632	753	881	1007	1127	1301	1558	1803	2149	2549	3112
Minimum Bending Radius of Cable (during installation)	mm	482	514	550	580	612	645	696	742	850	920	1000

Electrical Parameters:												
Maximum DC resistance of Conductor at 20°C	ohm/Km	0.641	0.443	0.320	0.253	0.206	0.164	0.125	0.100	0.0778	0.0605	0.0469
Approximate AC resistance of Conductor at 90°C	ohm/Km	0.822	0.568	0.411	0.325	0.265	0.211	0.162	0.13	0.102	0.08	0.064
Approximate Reactance at 50 Hertz	ohm/Km	0.13	0.13	0.12	0.11	0.11	0.11	0.10	0.10	0.10	0.09	0.09
Approximate Capacitance of Cable	µf/Km	0.22	0.25	0.28	0.31	0.33	0.36	0.41	0.44	0.49	0.54	0.59
Continuous Current Ratings												
1. Laid Direct, Ground Temp. 30°C & g =1.2°C m/W, depth of laying = 0.8m, laid singly	A	151	187	223	249	285	320	369	423	481	543	605
2. Drawn into Ducts, Ground Temp. 30°C & g =1.2°C m/W, depth of laying = 0.8m, laid singly	A	156	191	227	254	280	312	360	405	454	507	570
3. Laid singly in Air, Ambient temp. 35°C	A	166	207	258	294	336	391	460	534	616	727	837
One Second Short Circuit Current Rating of Conductor	kA	4.70	6.58	8.93	11.28	14.10	17.39	22.56	28.20	37.60	47.00	59.22

8.7/15 kV
Single Core
Aluminium Conductors
XLPE Insulated to
IEC 60502-2
Aluminium Wire
Armoured

1. Aluminium Conductor
2. Semiconductive conductor screen
3. XLPE Insulation
4. Semiconductive insulation screen
5. Copper tape screen
6. Bedding
7. Aluminium wire armour
8. Outer Sheath

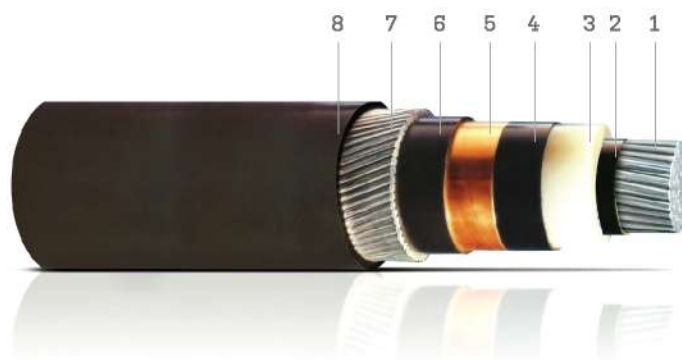

Table 15

Constructional Details:												
Nominal Area of Conductor	mm ²	50	70	95	120	150	185	240	300	400	500	630
Insulation Thickness (Nominal)	mm	4.5	4.5	4.5	4.5	4.5	4.5	4.5	4.5	4.5	4.5	4.5
Separation Sheath Thickness	mm	1.2	1.2	1.2	1.2	1.2	1.2	1.2	1.2	1.3	1.3	1.4
Armour Wire Diameter (Nominal)	mm	1.6	1.6	2	2	2	2	2	2	2.5	2.5	2.5
Outersheath Thickness (Nominal)	mm	1.9	2	2	2.1	2.1	2.2	2.3	2.3	2.5	2.6	2.7
Approximate Overall Diameter	mm	30.5	32	34.5	36	37.5	39.5	42	44	48.5	52	55.5
Approximate Cable Weight	Kg/Km	1103	1257	1513	1656	1824	2024	2330	2640	3229	3723	4400
Minimum Bending Radius of Cable (during installation)	mm	452	476	515	537	561	587	624	660	728	776	828

Electrical Parameters:												
Maximum DC resistance of Conductor at 20°C	ohm/Km	0.641	0.443	0.32	0.253	0.206	0.164	0.125	0.1	0.0778	0.0605	0.0469
Approximate AC resistance of Conductor at 90°C	ohm/Km	0.822	0.568	0.411	0.325	0.265	0.211	0.162	0.13	0.102	0.08	0.064
Approximate Reactance at 50 Hertz	ohm/Km	0.14	0.13	0.13	0.12	0.12	0.12	0.11	0.11	0.11	0.1	0.1
Approximate Capacitance of Cable	µf/Km	0.22	0.25	0.28	0.31	0.33	0.36	0.41	0.44	0.49	0.54	0.59
Continuous Current Ratings												
1. Laid Direct, Ground Temp. 30°C & g = 1.2°C m/W, depth of laying = 0.8m, laid in trefoil touching	A	151	187	223	249	280	316	360	405	454	507	570
2. Drawn into Ducts, Ground Temp. 30°C & g=1.2°C m/W, depth of laying = 0.8m, laid singly	A	151	187	218	245	267	298	338	374	405	445	490
3. Laid in Air in trefoil touching, Ambient Temp. 35°C	A	179	221	271	327	350	400	469	534	616	708	810
One second Short Circuit Current Rating of Conductor	kA	4.7	6.58	8.93	11.28	14.1	17.39	22.56	28.2	37.6	47	59.22

8.7 /15 kV
 Three Core
 Aluminium Conductors
 XLPE Insulated to
 IEC 60502-2
 Unarmoured

1. Aluminium conductor
2. Semiconductive conductor screen
3. XLPE insulation
4. Semiconductive insulation screen
5. Copper tape screen
6. Fillers
7. Tape binder
8. Outer sheath

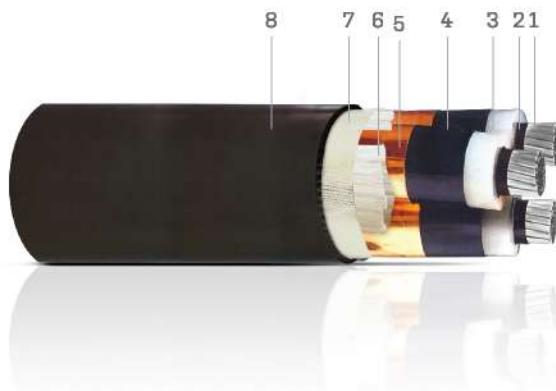
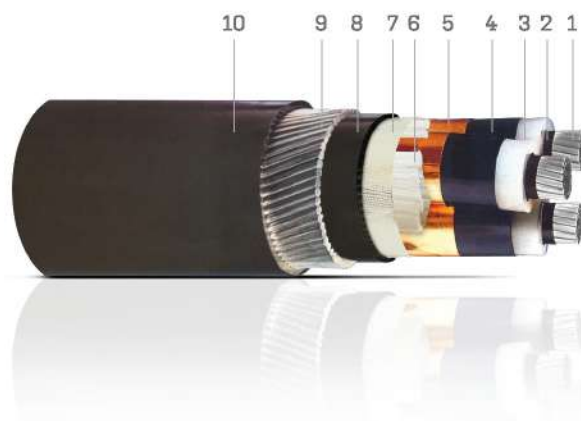

Table 16

Constructional Details:											
Nominal Area of Conductor	mm ²	25	35	50	70	95	120	150	185	240	300
Insulation Thickness (Nominal)	mm	4.5	4.5	4.5	4.5	4.5	4.5	4.5	4.5	4.5	4.5
Outersheath Thickness (Nominal)	mm	2.4	2.5	2.5	2.6	2.8	2.9	3	3.1	3.2	3.4
Approximate Overall Diameter	mm	43	45	50	53.5	57.5	60.5	64	68	73	78
Approximate Cable Weight	Kg/Km	1727	1958	2224	2633	3107	3533	3985	4574	5482	6376
Minimum Bending Radius of Cable (during installation)	mm	650	680	749	800	858	908	959	1014	1094	1170

Electrical Parameters:											
Maximum DC resistance of Conductor at 20°C	ohm/Km	1.20	0.868	0.641	0.443	0.32	0.253	0.206	0.164	0.125	0.1
Approximate AC resistance of Conductor at 90°C	ohm/Km	1.54	1.11	0.822	0.568	0.411	0.325	0.265	0.211	0.162	0.13
Approximate Reactance at 50 Hertz	ohm/Km	0.13	0.12	0.12	0.11	0.11	0.1	0.1	0.1	0.09	0.09
Approximate Capacitance of Cable	µf/Km	0.19	0.21	0.22	0.25	0.28	0.31	0.33	0.36	0.41	0.44
Continuous Current Ratings											
1. Laid Direct, Ground Temp. 30°C & g =1.02°C m/W, depth of laying = 0.8m, laid singly	A	127	148	151	184	217	250	283	316	358	410
2. Drawn into Ducts, Ground Temp. 30°C & g =1.2°C m/W, depth of laying = 0.8m, laid singly	A	106	127	127	156	189	212	241	274	316	354
3. Laid singly in Air, Ambient temp.35°C	A	130	156	163	201	239	282	316	368	431	488
One Second Short Circuit Current Rating of Conductor	kA	2.3	3.2	4.7	6.58	8.93	11.28	14.1	17.39	22.56	28.2

**8.7/15 kV
Three Core
Aluminium Conductors
XLPE Insulated to
IEC 60502-2
Steel Wire Armoured**



1. Aluminium conductor
2. Semiconductive conductor screen
3. XLPE Insulation
4. Semiconductive insulation screen
5. Copper tape screen
6. Fillers
7. Tape binder
8. Bedding
9. Galvanised steel wire armour
10. Outer sheath

Table 17

Constructional Details:											
Nominal Area of Conductor	mm ²	25	35	50	70	95	120	150	185	240	300
Insulation Thickness (Nominal)	mm	4.5	4.5	4.5	4.5	4.5	4.5	4.5	4.5	4.5	4.5
Separation Sheath Thickness	mm	1.4	1.4	1.5	1.5	1.6	1.7	1.7	1.8	1.9	2
Armour Wire Diameter (Nominal)	mm	2.5	2.5	2.5	2.5	2.5	2.5	2.5	3.15	3.15	3.15
Outersheath Thickness (Nominal)	mm	2.6	2.7	2.8	2.9	3	3.2	3.3	3.4	3.6	3.8
Approximate Overall Diameter	mm	53	56	58.5	62.0	66.0	69.5	73.0	78.5	84.0	89.0
Approximate Cable Weight	Kg/Km	4253	4595	5050	5660	6360	6890	8420	9270	10420	11710
Minimum Bending Radius of Cable (during installation)	mm	640	680	698	742	791	832	874	936	1003	1066

Electrical Parameters:											
Maximum DC resistance of Conductor at 20°C	ohm/Km	1.20	0.868	0.641	0.443	0.32	0.253	0.206	0.164	0.125	0.100
Approximate AC resistance of Conductor at 90°C	ohm/Km	1.54	1.11	0.822	0.568	0.411	0.325	0.265	0.211	0.162	0.130
Approximate Reactance at 50 Hertz	ohm/Km	0.13	0.12	0.12	0.11	0.11	0.10	0.10	0.010	0.09	0.09
Approximate Capacitance of Cable	µf/Km	0.19	0.21	0.22	0.25	0.28	0.31	0.33	0.36	0.41	0.44
Continuous Current Ratings											
1. Laid Direct, Ground Temp. 30°C & g = 1.2°C m/W, depth of laying = 0.8m, laid singly	A	120	140	142	174	205	236	267	298	338	387
2. Drawn into Ducts, Ground Temp. 30°C & g = 1.2°C m/W, depth of laying = 0.8m, laid singly	A	100	120	120	147	178	200	227	258	298	334
3. Laid in Air singly, Ambient Temp. 35°C	A	125	150	156	193	230	271	304	354	414	469
One second Short Circuit Current Rating of Conductor	kA	2.3	3.2	4.7	6.58	8.93	11.28	14.1	17.39	22.56	28.2



Correction Factors

Cables laid direct in ground.

Table 18

Variation in Ground Temperature:							
Ground temperature* C	15	20	25	30	35	40	45
All Cables	1.11	1.08	1.04	1.00	0.96	0.91	0.87

Table 19

Correction factors for depth of laying (to centre of cable or trefoil group of cables):		
Depth of laying m	Up to 300mm ²	Above 300mm ²
0.50	-	-
0.60	-	-
0.80	1.00	1.00
1.00	0.98	0.97
1.25	0.96	0.95
1.50	0.95	0.94
1.75	0.94	0.92
2.00	0.92	0.90
2.50	0.91	0.89
3.00 or more	0.90	0.88

Table 20

Correction factors for variation in thermal resistivity of soil (Average values)							
Size of cables mm ²	Soil thermal resistivity in K.m./W						
	0.8	0.9	1.0	1.5	2.0	2.5	3.0
Single core							
50	1.15	1.11	1.07	0.91	0.81	0.73	0.68
70	1.16	1.12	1.07	0.91	0.81	0.73	0.68
95	1.16	1.12	1.07	0.91	0.81	0.73	0.68
120	1.16	1.12	1.07	0.91	0.81	0.73	0.68
150	1.17	1.12	1.07	0.91	0.81	0.73	0.68
185	1.17	1.12	1.07	0.91	0.81	0.73	0.68
240	1.17	1.12	1.07	0.91	0.80	0.73	0.68
300	1.18	1.12	1.07	0.91	0.80	0.73	0.68
400	1.18	1.12	1.07	0.91	0.80	0.73	0.67
500	1.18	1.12	1.07	0.91	0.80	0.73	0.67
630	1.18	1.12	1.07	0.91	0.80	0.73	0.67
Multicore							
25	1.13	1.09	1.06	0.92	0.83	0.76	0.71
35	1.13	1.09	1.06	0.92	0.83	0.76	0.71
50	1.13	1.09	1.06	0.92	0.83	0.76	0.71
70	1.14	1.09	1.06	0.92	0.83	0.75	0.70
95	1.14	1.09	1.06	0.92	0.83	0.75	0.70
120	1.14	1.10	1.06	0.92	0.82	0.75	0.69
150	1.14	1.10	1.06	0.92	0.82	0.75	0.69
185	1.14	1.10	1.06	0.92	0.82	0.74	0.69
240	1.15	1.10	1.07	0.92	0.81	0.74	0.69
300	1.15	1.10	1.07	0.92	0.81	0.74	0.69

Group Correction Factors

Table 21

Group Correction Factors For Circuits of Three Single Core Cables in Trefoil and Laid Flat Touching, Horizontal Formation (Average Values)



Number of Circuits	Spacing of circuits					
	Touching +		0.15 m*	0.30 m	0.45 m	0.60 m
	Trefoil	Laid flat				
2	0.78	0.81	0.81	0.85	0.88	0.90
3	0.66	0.68	0.71	0.76	0.80	0.83
4	0.59	0.62	0.65	0.72	0.76	0.80
5	0.55	0.58	0.61	0.68	0.73	0.77
6	0.52	0.55	0.58	0.66	0.72	0.76

* This configuration, at 0.15m spacing, may not be practical for the larger size cables.

Table 22

Group Correction Factors For Multicore cables in Horizontal formation

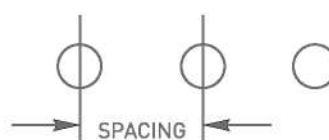

Numbers of Cables in Group	Spacing				
	Touching	0.15 m	0.30 m	0.45 m	0.60 m
2	0.80	0.85	0.89	0.90	0.92
3	0.68	0.75	0.80	0.84	0.86
4	0.62	0.70	0.77	0.80	0.84
5	0.57	0.66	0.73	0.78	0.81
6	0.55	0.63	0.71	0.76	0.80

Cables installed in single way ducts:

The term 'ducts' applies to single earthenware, fibre or plastic pipes.

Table 23

Variation in Ground Temperature:							
Ground temperature* C	15	20	25	30	35	40	45
All Cables	1.11	1.08	1.04	1.00	0.96	0.91	0.87

Table 24

Correction factors for depth of laying [to centre of cable or trefoil group of cables]:		
Depth of laying m	Up to 300mm ²	Above 300mm ²
0.50	-	-
0.60	-	-
0.80	1.00	1.00
1.00	0.98	0.99
1.25	0.95	0.97
1.50	0.93	0.96
1.75	0.92	0.95
2.00	0.90	0.94
2.50	0.89	0.93
3.00	0.88	0.92
or more		

Table 25

Correction factors for variation in thermal resistivity of soil (Average values)							
Size of cables mm ²	Soil thermal resistivity in K.m./W						
	0.8	0.9	1.0	1.5	2.0	2.5	3.0
Single core							
50	1.08	1.06	1.04	0.94	0.87	0.82	0.77
70	1.09	1.06	1.04	0.94	0.87	0.81	0.76
95	1.09	1.06	1.04	0.94	0.87	0.81	0.76
120	1.10	1.07	1.04	0.94	0.86	0.80	0.75
150	1.10	1.07	1.04	0.94	0.86	0.80	0.75
185	1.10	1.07	1.04	0.93	0.86	0.79	0.75
240	1.11	1.07	1.04	0.93	0.86	0.79	0.74
300	1.11	1.08	1.05	0.93	0.85	0.79	0.74
400	1.11	1.08	1.05	0.93	0.85	0.78	0.73
500	1.11	1.08	1.05	0.93	0.85	0.78	0.73
630	1.12	1.08	1.05	0.93	0.84	0.78	0.72
Multicore							
25	1.05	1.03	1.02	0.96	0.91	0.87	0.83
35	1.05	1.03	1.02	0.96	0.91	0.87	0.83
50	1.05	1.03	1.02	0.96	0.91	0.87	0.83
70	1.05	1.04	1.02	0.96	0.91	0.86	0.82
95	1.06	1.04	1.02	0.96	0.91	0.86	0.82
120	1.06	1.04	1.03	0.95	0.90	0.85	0.81
150	1.06	1.04	1.03	0.95	0.90	0.85	0.80
185	1.07	1.05	1.03	0.95	0.89	0.84	0.80
240	1.07	1.05	1.03	0.95	0.89	0.84	0.79
300	1.07	1.05	1.03	0.95	0.88	0.83	0.78

Group Correction Factors

Table 26

Group Correction factors for single core cables in trefoil single way ducts, horizontal formation (Average values)			
			
Number of Circuits	Spacing		
	Touching	0.45 m	0.60 m
2	0.85	0.88	0.90
3	0.75	0.80	0.83
4	0.70	0.76	0.80
5	0.67	0.73	0.77
6	0.64	0.71	0.76

Table 27

Group correction factors for multicore cables in single way ducts, horizontal formation (Average values)				
				
Number of Ducts in Ground	Spacing			
	Touching	0.30 m	0.45 m	0.60 m
2	0.88	0.91	0.93	0.94
3	0.80	0.84	0.87	0.89
4	0.75	0.81	0.84	0.87
5	0.71	0.77	0.82	0.85
6	0.69	0.75	0.80	0.84

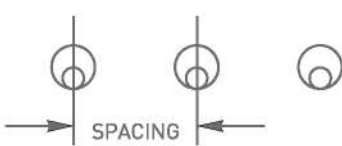

Cables installed in free air:

All the Correction for cables run in air are based upon the assumption that they are shielded from direct sunlight and without restriction of ventilation.

Table 28

Variation in Air Temperature:							
Ambient temperature* C	25	30	35	40	45	50	55
All Cables	1.09	1.04	1.00	0.95	0.90	0.85	0.80

Effect of grouping cables: No reduction in rating is necessary where there is free circulation of air around the circuits provided that:

1. The horizontal clearance between circuits is not less than twice the overall diameter of an individual cable.
2. The vertical clearance between circuits is not less than four times the diameter of an individual cable.
3. If the number of circuits exceeds three, they are installed in a horizontal plane.

Short Circuit Rating

Copper Conductor

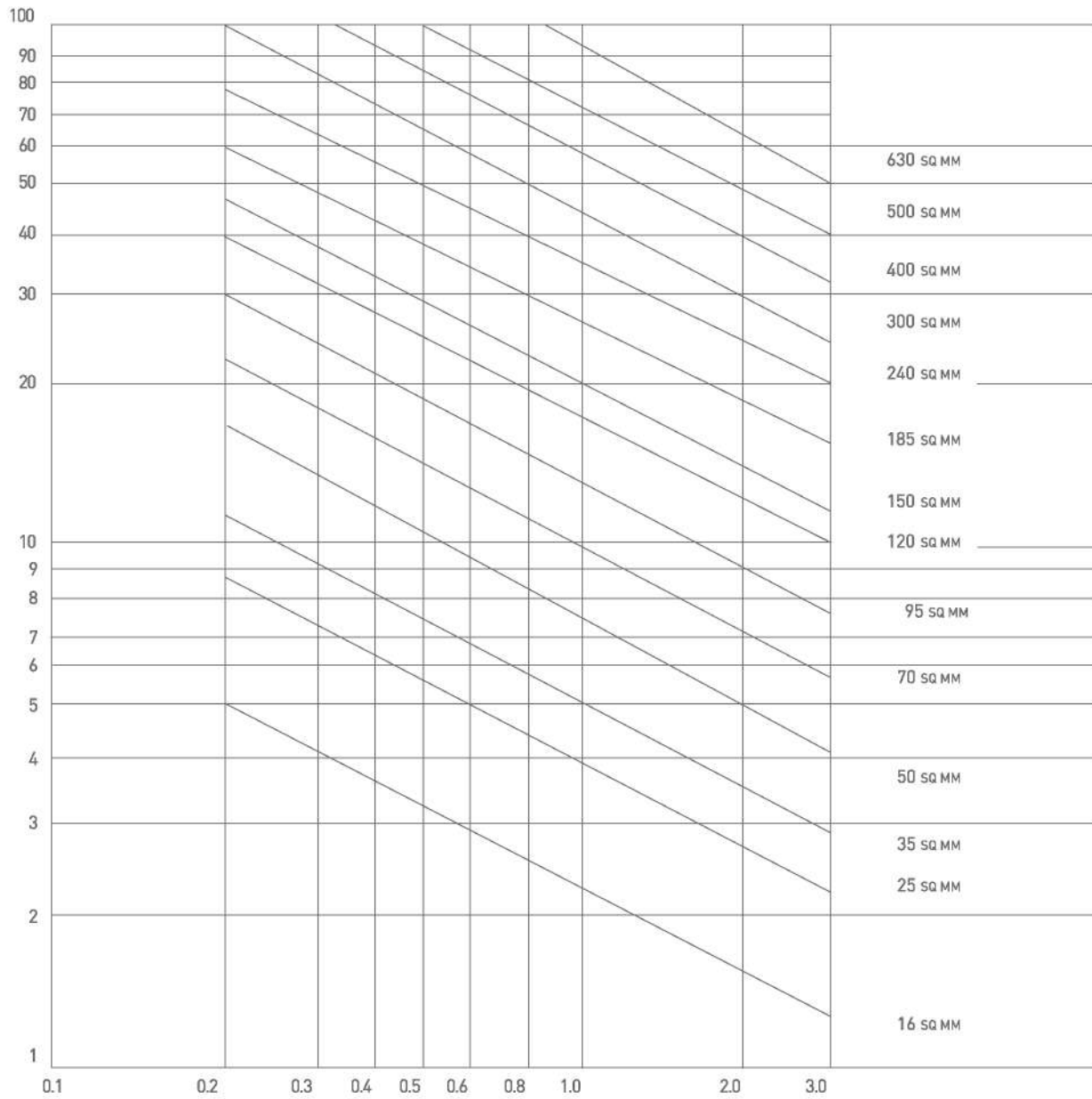



Short Circuit Rating

Aluminium Conductor

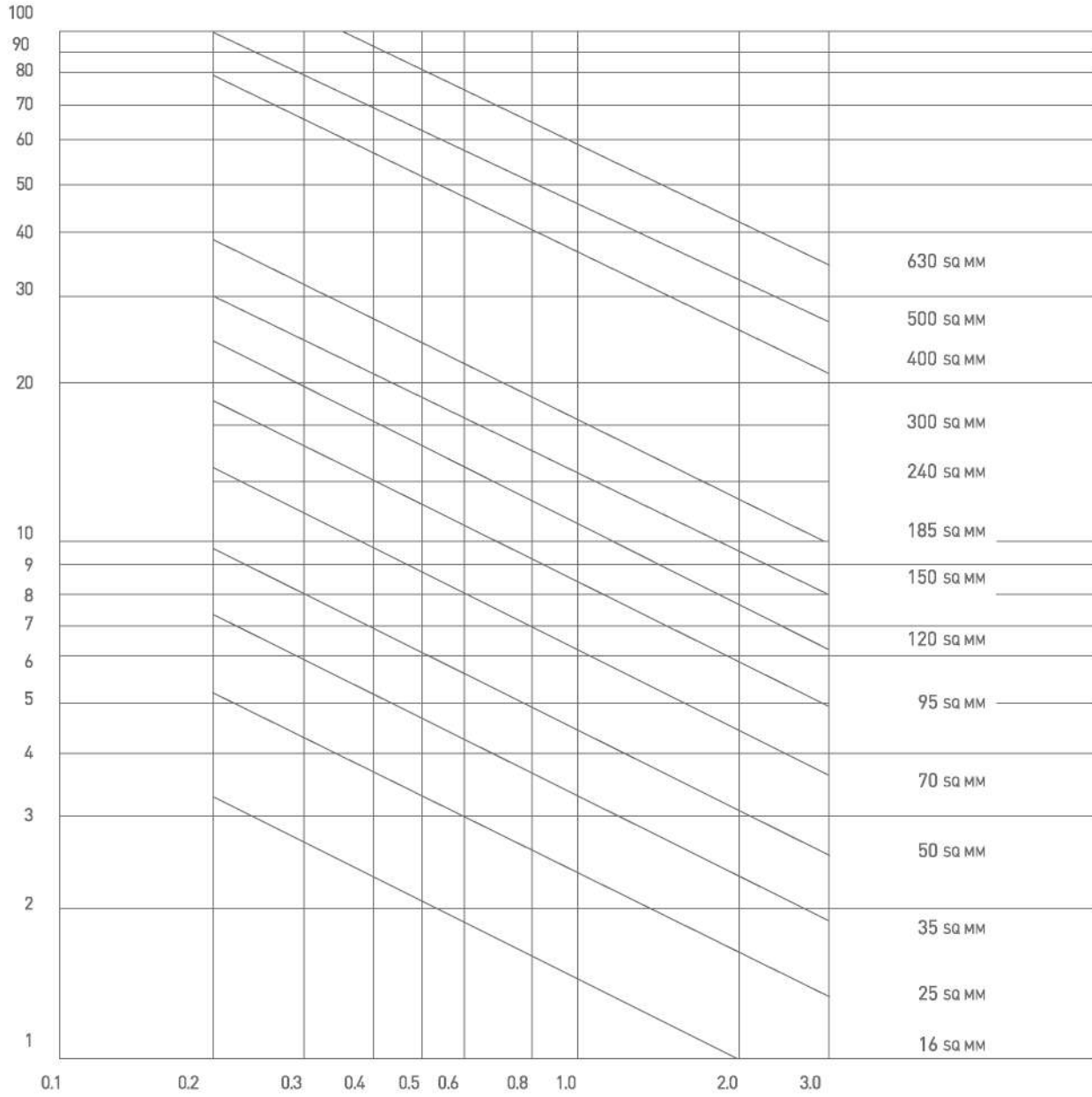

Laying, Handling And Storage

Handling:

Damage to cable can occur due to incorrect handling to which the drums and cables may be subjected, causing breakdown of the drum flanges and in exceptional cases, movement of the drum barrel takes place. Once this breakdown of the drum occurs the cable is immediately exposed to damage.

Fork-lift trucks may be used in handling provided that care is exercised not to damage or remove the protective lagging when pushing the ' fork' under the drum flanges. Unloading can also be safely accomplished by means of ramps and winches. (See Fig. 1 & 2.)

Under no circumstances should a drum be rolled off a vehicle on to a 'cushion' of sand, tarpaulin, etc. This action could crumple the flanges and barrel of the drum, driving splinters and or nails into the cable, (See Flg.3)

Rolling Drums:

Drums of cable must always be rolled in the direction shown by the arrow painted on the flanges, but such rolling should in any case be kept to a minimum.

Turning Drums:

The best way to turn a cable drum is to roll it on to two well-greased thin plates or boards about 2 feet square. The plates can then be used as a turntable and the drum rotated to the desired direction.

Lowering of Lifting Drums:

When drums are moved from one level to another, e.g. truck to ground, wharf to ship, etc., lifting and lowering gear must always be used. When drums are lifted from the upper layer of a tiered stack, care must be taken to ensure that no movement of the bottom layer occurs so as to cause collapse. Drums, whether loaded or empty, and too heavy to be manhandled, should always be slung; they should never be dropped. (See flg & 2).

1. Storage

If at any time the drums of cable are required to be stored for reasonably long periods, e.g. prior to shipment or Installation, the following points should be noted.

- 1.1 The site for storage of drums should be well drained. Hard packed soil, or preferably a concrete surface, which will not allow the drums to sink and so give rise to damage due to the extreme difficulty in moving drums when they are sunk into the ground.
- 1.2 All drums should be stored with the lagging intact, and in such a manner as to leave sufficient space between them for air circulation. Check and tighten barrel bolts on the drums at regular intervals.
- 1.3 Tier stacking of drums is not recommended In no circumstances must the drums be stored on the flat i.e. with flanges horizontal. (Fig.4)
When lifting drums of cable for loading or unloading, spindles must always be used in conjunction with crane slings, chain or lifting beams. On no account any drum be lifted by wire slings. (Fig. 1)
When lifting drums of cable, lifting beams or stretchers between the sling of chain pairs must be used to prevent flanges crushing on to the cable. (See Fig. 1)

NOTE: Normally the hooks or slings should be closed to the drum flanges.

- 1.4 All drums during installation (i.e. when the lagging have been removed) should be stored with the rims of flange touching, so that there is no danger of the flanges of drums coming into accidental contact with unprotected cable on other drums.

IMPORTANT: Cable ends must be sealed with end cap during storage and transportation.

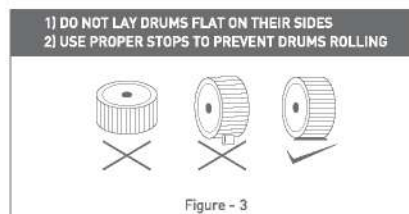
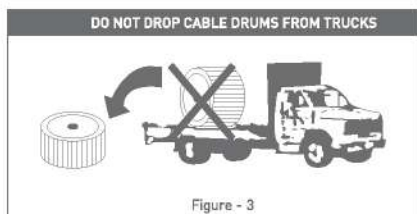
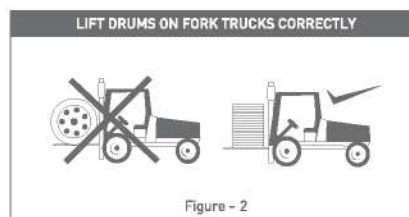
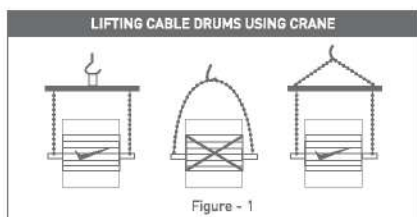

Laying of Cables

The cable should preferably be drawn to its that position in a continuous manner During steps. The cable will settle between rollers and may cause high strain on men and machines during restarting . Whether the pulling is manual or with a winch. It is necessary for one man to be stationed at the drum with a plank of wood wedged against the flange of the drum so that over running of the drum is prevented if the pulling stops. Otherwise. Many loose turns can easily develop on the drum.

When pulling by a winch it is advantageous for the cable end to be taken by hand as far as possible before attaching the winch rope. This allows the leading cable rollers. Skid plates. etc to take the load and settle under well-controlled conditions The winch operator must. at all times, carefully observe the dynamometer to prevent overloading. On long pulls, good communication is essential, preferably by radio.

When pulling a power winch, more attention has to be given to the maximum pulling load which is permissible. For such installations a pulling eye attached to the conductors is necessary and for copper conductors a pulling tension of 6 kg force per sq. mm of total conductor area can be applied (with the provision of 2000 kg force maximum).

Graphite paste should be used for lubrication when cables are being pulled into ducts or pipes.

For open trench and. Straight installation, a cable stocking can be used. It is advisable, however, to protect the PVC oversheath with a layer of bitumen tape applied with 50% overlap.

Cables should never be bent to a small radius. As large a radius as space permits should be adopted. Under no circumstances should the bending radius be less than the minimum permissible limits. It is particularly important to have a generous bending radius when cables are to be pulled by a power winch. So as to keep within the maximum permissible pulling tension and prevent the cable being flattened around bends or in ducts.

DO NOT PULL CABLE
ACROSS LONG
UNSUPPORTING SPANS



DO NOT DRAG CABLE
AGAINST SHARP EDGES

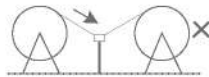

PROVIDE FREELY
ROTATING SUPPORTS



DO NOT PULL CABLES
WITH POWER VEHICLES

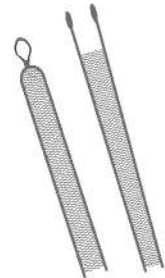
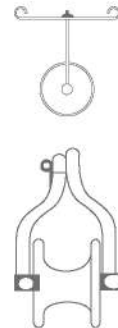
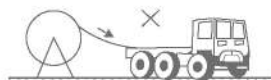

Final Placing of Cable

Before disconnecting the pulling rope, the cable is laid off. i.e. starting at one end. It is carefully lifted from the rollers and deposited on the bottom of the trench. About 10m of cable should be lifted at one time, any slack being carried forward. The end position of a cable run may require double handling because it is not possible to draw cables straight into buildings. In this case the cable is overpulled, then man-handled into the required position. At all times the loops should be kept as large as possible so that the bending radius is always above the minimum permitted. Similarly at the drum locations the necessary length of cable may be unwound from the drum and laid out. In a figure of '8' if space is limited, prior to cutting to length and placing into position immediately after cutting the cable ends must be suitably sealed prevent ingress of moisture. In this respect it is also important to carefully examine the pulling end seal to ensure that it has not been damaged during laying. [see figures 14 & 15]

Backfilling and Reinstatement.

Prior to backfilling, it is necessary to carry out a visual inspection, and items which need to be checked are:

- 1) The cables have a suitable bedding, such as sieved sand or soil. Stone chips and other sharp objects in the cable route should be removed.
- 2) The spacing is correct if there is more than one cable in the trench.
- 3) Pulling equipment is carefully removed,
- 4) The cable is free from obvious damage caused during installation. A very high proportion of cable failures in service are due to such damage. It may be necessary to inspect the underside with a mirror. In such cases it is advisable to make a first inspection whilst the cable is still on rollers.

DO NOT ATTEMPT "COILING
OF CABLE ON THE GROUND

FIG - 14



ON THE GROUND CABLE CAN BE FLAKED
IN A FIGURE OF EIGHT FORMATION

FIG - 15

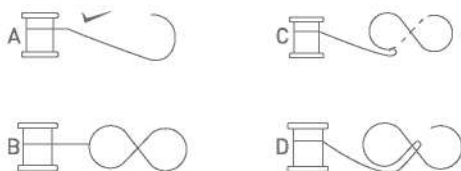

BREAKING BARRIERS IN THE INDUSTRY

Pakistan Cables is proud to introduce the nation's highest voltage grade -69 kV CCV line -for Medium Voltage cables with world class German technology.



REVOLUTIONIZING TRANSMISSION WITH TECHNOLOGY

ACCC Conductors - Our high-capacity, low-sag ACCC Conductors enable greater current-carrying capacity with lower line losses—ideal for grid upgrades, long spans, and energy-efficient power delivery.



MAKE THE SWITCH.

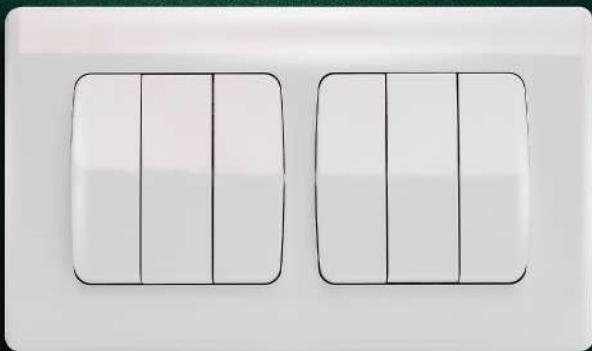

Pakistan Cables Wiring Accessories are a versatile range of world class electrical switches with superior quality and exquisite designs.

PEHAL KARNE MEIN SABSE AAGAY

E-STORE NOW DELIVERING IN



C I T I E S O F P A K I S T A N



www.pakistancables-estore.com

 **Head Office:** Arif Habib Centre, 1st Floor, 23 M.T Khan Road,
Karachi - 74000, Pakistan

 pakistancables.com

 +92-21-111-CABLES (222-537)

 info@pakistancables.com | sales@pakistancables.com | export@pakistancables.com

