

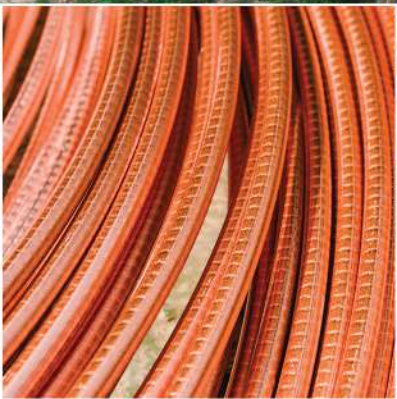

TRUSTED NOT TO COMPROMISE

Product Catalogue  
**Low Voltage  
Cables**







# Contents

List of Tables	01
Specification & Construction	02
Conductor Data	05
Dimensions & Weights	06
Current Carrying Capacity & Voltage Drop	12
Correction Factors	45
Short Circuit Rating	51
Handling & Storage	53
Laying	55

# List of Tables

TABLE #	TABLE TITLE	PAGE #
	<b>CONDUCTOR DATA</b>	
01	• Class 2 Stranded Conductors for Single-core and Multi-core cables	05
02	• Diameters of stranded circular compacted copper and aluminium conductors	05
	<b>DIMENSIONS &amp; WEIGHTS</b>	
03-04-05	• PVC Insulated Power Cables 600/1000 Volts	06 - 08
06-07-08	• XLPE Insulated Power Cables 600/1000 Volts	09 - 11
	<b>CURRENT CARRYING CAPACITY AND VOLTAGE DROP</b>	
09	• TABLE 4D1A — Single-core 70°C PVC Insulated cables, non-armoured with or without sheath (COPPER CONDUCTORS)	13
10	• TABLE 4D1B — Single-core 70°C PVC Insulated cables, non-armoured with or without sheath (COPPER CONDUCTORS)	14
11	• TABLE 4D2A — Multi-core 70°C PVC Insulated and Sheathed cables, non-armoured (COPPER CONDUCTORS)	15
12	• TABLE 4D2B — Multi-core 70°C PVC Insulated and Sheathed cables, non-armoured (COPPER CONDUCTORS)	16
13	• TABLE 4D3A — Single-core 70°C armoured PVC Insulated and Sheathed cables, Aluminium wire armour (COPPER CONDUCTORS)	17
14	• TABLE 4D3B — Single-core 70°C armoured PVC Insulated and Sheathed cables, Aluminium wire armour (COPPER CONDUCTORS)	18
15	• TABLE 4D4A — Multi-core 70°C armoured PVC Insulated and Sheathed cables, (COPPER CONDUCTORS)	19
16	• TABLE 4D4B — Multi-core 70°C armoured PVC Insulated and Sheathed cables, (COPPER CONDUCTORS)	20
17	• TABLE 4H1A — Single-core 70°C PVC Insulated cables, non-armoured with or without sheath (ALUMINIUM CONDUCTORS)	21
18	• TABLE 4H1B — Single-core 70°C PVC Insulated cables, non-armoured with or without sheath (ALUMINIUM CONDUCTORS)	22
19	• TABLE 4H2A — Multi-core 70°C PVC Insulated and Sheathed cables, non-armoured (ALUMINIUM CONDUCTORS)	23
20	• TABLE 4H2B — Multi-core 70°C PVC Insulated and Sheathed cables, non-armoured (ALUMINIUM CONDUCTORS)	24
21	• TABLE 4H3A — Single-core 70°C armoured Insulated and PVC Sheathed cables, Aluminium wire armour (ALUMINIUM CONDUCTORS)	25
22	• TABLE 4H3B — Single-core 70°C armoured PVC Insulated and Sheathed cables, Aluminium wire armour (ALUMINIUM CONDUCTORS)	26
23	• TABLE 4H4A — Multi-core 70°C armoured PVC Insulated and Sheathed cables, (ALUMINIUM CONDUCTORS)	27
24	• TABLE 4H4B — Multi-core 70°C armoured PVC Insulated and Sheathed cables, (ALUMINIUM CONDUCTORS)	28
25	• TABLE 4E1A — Single-core 90°C XLPE Insulated cables, unarmoured with or without PVC sheath (COPPER CONDUCTORS)	29
26	• TABLE 4E1B — Single-core 90°C XLPE Insulated cables, unarmoured with or without PVC sheath (COPPER CONDUCTORS)	30
27	• TABLE 4E2A — Multi-core 90°C XLPE Insulated and PVC Sheathed cables, non-armoured (COPPER CONDUCTORS)	31
28	• TABLE 4E2B — Multi-core 90°C XLPE Insulated and PVC Sheathed cables, non-armoured (COPPER CONDUCTORS)	32
29	• TABLE 4E3A — Single-core 90°C armoured XLPE Insulated and PVC Sheathed cables, Aluminium wire armour (COPPER CONDUCTORS)	33
30	• TABLE 4E3B — Single-core 90°C armoured XLPE Insulated and PVC Sheathed cables, Aluminium wire armour (COPPER CONDUCTORS)	34
31	• TABLE 4E4A — Multi-core 90°C armoured XLPE Insulated and PVC Sheathed cables (COPPER CONDUCTORS)	35
32	• TABLE 4E4B — Multi-core 90°C armoured XLPE Insulated and PVC Sheathed cables (COPPER CONDUCTORS)	36
33	• TABLE 4J1A — Single-core 90°C XLPE Insulated cables, unarmoured, with or without PVC sheath (ALUMINIUM CONDUCTORS)	37
34	• TABLE 4J1B — Single-core 90°C XLPE Insulated cables, unarmoured, with or without PVC sheath (ALUMINIUM CONDUCTORS)	38
35	• TABLE 4J2A — Multi-core 90°C XLPE Insulated and PVC Sheathed cables, non-armoured (ALUMINIUM CONDUCTORS)	39
36	• TABLE 4J2B — Multi-core 90°C XLPE Insulated and PVC Sheathed cables, non-armoured (ALUMINIUM CONDUCTORS)	40
37	• TABLE 4J3A — Single-core 90°C armoured XLPE Insulated and PVC Sheathed cables Aluminium wire armour (ALUMINIUM CONDUCTORS)	41
38	• TABLE 4J3B — Single-core 90°C armoured XLPE Insulated and PVC Sheathed cables Aluminium wire armour (ALUMINIUM CONDUCTORS)	42
39	• TABLE 4J4A — Multi-core 90°C armoured XLPE Insulated and PVC Sheathed cables (ALUMINIUM CONDUCTORS)	43
40	• TABLE 4J4B — Multi-core 90°C armoured XLPE Insulated and PVC Sheathed cables (ALUMINIUM CONDUCTORS)	44
	<b>CORRECTION FACTORS:</b>	
41	• TABLE 4B1 — Rating factors for ambient temperatures, for cables in air.	45
42	• TABLE 4B2 — Rating factors for ambient ground temperatures, for cables buried direct or in underground conduit.	45
43	• TABLE 4B3 — Rating factors for soil resistivity, for cables buried direct or in underground conduit.	45
44	• TABLE 4C1 — Rating factors for one circuit or one Multi-core cable or for a group of circuits or Multi-core cables.	46
45	• TABLE 4C2 — Rating factors for more than one circuit, for cables laid directly in the ground.	47
46-47	• TABLE 4C3 — Rating factors for more than one circuit, cables laid in ducts in the ground.	48
48	• TABLE 4C4 — Rating factors for groups of more than one Multi-core cable on trays or cable ladders.	49
49	• TABLE 4C5 — Rating factors for groups of one or more circuits of Single-core cables on trays or cable ladders.	50

# Specification and Construction

## Specification

Low Voltage Power Cables with PVC Insulation are manufactured to BS 6346 "Electric Cables, PVC Insulated, armoured cables for 600/1000V & 1900/3300V" and with XLPE insulation to IEC 60502-1 "Part-1: Cables for rated voltages of 1 kV ( $U_m = 1.2$  kV) & 3 kV ( $U_m = 3.6$  kV)".

## Conductors

The conductors in Pakistan Cables fixed power cables are of high-conductivity copper or high purity aluminium and meet the requirements of BSEN 60228 - "Conductors of insulated cables".

Dependent upon the actual cable type, they may be of stranded copper or aluminium. Conductors are either Circular Compacted or Sector Shaped as mentioned in relevant tables.

## Insulation

According to its particular standard specification a cable will be insulated with either:

**PVC** (polyvinyl chloride) - BS 6346  
**XLPE** (cross-linked polyethylene)- IEC 60502-1

**PVC** is a clean, easy to handle material with good electrical characteristics and reasonable resistance to a range of possible contaminants such as water, oils and chemicals. It is inherently

flame-retardant and is suitable for a maximum continuous conductor operating temperature of 70°C.

**XLPE** matches all these attributes but goes a stage or two further. The good qualities of polyethylene are retained but at high temperatures the toughness and physical properties are improved. In particular there is greatly-enhanced resistance to deformation.

Having superior thermal and mechanical properties compared with PVC, XLPE also has higher insulation resistance, enabling its thickness to be reduced, leading to a corresponding reduction in the overall diameter and weight of a finished cable.

The main comparative consideration however, is the XLPE permits the operating temperature of cables to be raised substantially without suffering thermal deformation or degradation.

The continuous current ratings of XLPE insulated cables are based upon a maximum conductor temperature of 90°C as opposed to 70°C for PVC insulated types.

Short-circuit ratings are also higher, XLPE accepting 250°C as a final conductor temperature at the end of a short circuit compared with 140/160°C for PVC insulated cables. As a result, in situations where conductor size is governed by current rating rather than voltage drop, it may be possible to use a smaller conductor size.



## Core identification

XLPE / PVC cables have coloured cores

Number of cores	Colours
Single	Black or Red
Two	Red, Black
Three	Red, Yellow, Blue
Four	Red, Yellow, Blue, Black

Black denotes the neutral and other colours for phase conductors in two, three or four core cables.

Following colour identification is also offered provided the quantity is economical:

Number of cores	Colours
Single	Blue or Brown
Two	Blue, Brown
Three	Brown, Black, Grey
Four	Brown, Black, Grey, Blue

Blue denotes the neutral and other colours for phase conductors in two, three and four core cables.

## Bedding

A layer of extruded PVC around the core assembly separates the heart of the cable from - and provides a secure bedding for - the metallic armour.

## Armour

Steel wire armour is necessary to guard against mechanical damage to the cable.

Single wire armour consists of galvanized steel wires applied spirally over the bedding.

Single core cables for ac systems are never provided with steel armour because of its effect in increasing the losses resulting in overheating of cable. Where necessary, non-magnetic aluminium wire can be provided.

## Outer covering

The standard form of protection for un-armoured and armoured cables is an extruded PVC over-sheath.

Pakistan Cables also offers cables with PVC sheathing having low HCl emission and reduced flame propagation characteristics. LSF PVC Compound have oxygen index of more than 30.

Outer sheath with Anti-termite and Anti-Rodent resistance characteristic can also be offered whenever required.



## Conductor Data

Table 1

### Class 2 Stranded Conductors for Single-core and Multi-core cables

Nominal cross-sectional area mm <sup>2</sup>	Minimum number of wires in the conductor						Maximum resistance of conductor at 20°C	
	Circular Conductor		Circular Compacted Conductor		Shaped Conductor		Annealed Copper Conductor	Plain aluminium Conductor
	Cu	Al	Cu	Al	Cu	Al	Plain wires	
1.5	7	-	6	-	-	-	12.1	-
2.5	7	-	6	-	-	-	7.41	-
4	7	7	6	-	-	-	4.61	-
6	7	7	6	-	-	-	3.08	-
10	7	7	6	-	-	-	1.83	3.08
16	7	7	6	6	-	-	1.15	1.91
25	7	7	6	6	6	6	0.727	1.20
35	7	7	6	6	6	6	0.524	0.868
50	19	19	6	6	6	6	0.387	0.641
70	19	19	12	12	12	12	0.268	0.443
95	19	19	15	15	15	15	0.193	0.320
120	37	37	18	15	18	15	0.153	0.253
150	37	37	18	15	18	15	0.124	0.206
185	37	37	30	30	30	30	0.0991	0.164
240	37	37	34	30	34	30	0.0754	0.125
300	61	61	34	30	34	30	0.0601	0.100
400	61	61	-	-	-	-	0.0470	0.778
500	61	61	-	-	-	-	0.0366	0.0605
630	91	91	-	-	-	-	0.0283	0.0469
800	91	91	-	-	-	-	0.0221	0.0369
1000	91	91	-	-	-	-	0.0176	0.0291

Table 2

### Diameters of stranded circular compacted copper and aluminium conductors

Cross-sectional Area mm <sup>2</sup>	Stranded Compacted circular conductors (Class 2)	
	Minimum diameter mm	Maximum diameter mm
16	4.6	5.2
25	5.6	6.5
35	6.6	7.5
50	7.7	8.6
70	9.3	10.2
95	11.0	12.0
120	12.3	13.5
150	13.7	15.0
185	15.3	16.8
240	17.6	19.2
300	19.7	21.6

# Dimensions & Weights

Table 3

## PVC Insulated Power Cables

600 / 1000 V Unarmoured and single wire armoured, PVC over-sheathed cables.

BS 6346

Nominal Area of Conductor		Nominal Thickness of Insulation	Unarmoured			Armoured			
			Approx. Cable Diameter overall	Approximate Cable weight		Armour Wire Diameter	Approx. Cable Diameter overall	Approximate Cable weight	
				Copper	Aluminium			Copper	Aluminium
mm <sup>2</sup>		mm	mm	kg / km		mm	mm	kg / km	
S I N G L E C O R E	* 50	1.4	15.10	600	280	♣ 1.25	19.40	780	460
	* 70	1.4	16.90	810	360	♣ 1.25	21.10	1030	580
	* 95	1.6	19.40	1110	480	♣ 1.25	23.40	1330	700
	* 120	1.6	21.00	1350	570	♣ 1.6	26.30	1680	900
	* 150	1.8	23.20	1650	690	♣ 1.6	28.30	2000	1040
	* 185	2.0	25.80	2060	860	♣ 1.6	30.80	2430	1230
	* 240	2.2	29.00	2670	1090	♣ 1.6	34.10	3090	1510
	* 300	2.4	32.10	3320	1340	♣ 1.6	37.00	3770	1790
	^ 400	2.6	35.80	4190	1670	♣ 2.0	42.00	4830	2310
	^ 500	2.8	39.60	5230	2060	♣ 2.0	45.85	5920	2750
	^ 630	2.8	43.80	6630	2630	♣ 2.0	49.70	7420	3420
^ 800	2.8	48.30	8330	2940	♣ 2.5	55.80	9500	4110	
^ 1000	3.0	53.70	10440	3750	♣ 2.5	61.00	11760	5070	
T W O C O R E	* 1.5	0.6	-	120	-	0.90	13.00	280	-
	* 2.5	0.7	-	170	-	0.90	14.25	370	-
	* 4.0	0.8	-	220	-	0.90	15.75	460	-
	* 6.0	0.8	-	290	-	0.90	17.10	550	-
	* 10	1.0	-	460	-	1.25	20.10	860	-
	* 16	1.0	19.00	520	320	1.25	22.82	960	760
	* 25	1.2	21.00	690	370	1.60	26.70	1340	1020
	# 35	1.2	20.10	950	510	1.60	25.00	1610	1170
	# 50	1.4	22.80	1260	660	1.60	27.80	2020	1420
	# 70	1.4	25.50	1700	840	1.60	30.40	2520	1660
	# 95	1.6	29.30	2310	1110	2.00	35.90	3520	2320
	# 120	1.6	31.80	2880	1360	2.00	38.65	4200	2680
	# 150	1.8	35.10	3520	1660	2.00	41.80	4960	3100
	# 185	2.0	39.10	4390	2040	2.50	46.40	6390	4040
	# 240	2.2	43.90	5760	2700	2.50	51.20	8020	4960
	# 300	2.4	48.70	7160	3320	2.50	56.40	9710	5870
# 400	2.6	54.20	9040	4120	2.50	61.90	11850	6930	

\* Circular/Circular Compacted Stranded Conductors

# Shaped Stranded Conductors

♣ Aluminium Wire Armoured

^ Circular Stranded Conductor



# Dimensions & Weights

Table 4

## PVC Insulated Power Cables

600 / 1000 V Unarmoured and single wire armoured, PVC over-sheathed cables.

BS 6346

Nominal Area of Conductor		Nominal Thickness of Insulation	Unarmoured			Armoured			
			Approx. Cable Diameter overall	Approximate Cable weight		Armour Wire Diameter	Approx. Cable Diameter overall	Approximate Cable weight	
				Copper	Aluminium			Copper	Aluminium
mm <sup>2</sup>		mm	mm	kg / km		mm	mm	kg / km	
T H R E E C O R E	* 1.5	0.6	-	150	-	0.90	13.50	370	-
	* 2.5	0.7	-	210	-	0.90	14.80	500	-
	* 4.0	0.8	-	290	-	0.90	16.40	630	-
	* 6.0	0.8	-	390	-	1.25	18.00	750	-
	* 10	1.0	-	600	-	1.25	21.20	1050	-
	* 16	1.0	19.77	710	400	1.25	23.10	1210	900
	* 25	1.2	25.80	1100	620	1.60	28.20	1780	1300
	# 35	1.2	22.50	1300	640	1.60	30.80	2170	1510
	# 50	1.4	25.60	1720	820	1.60	30.50	2580	1680
	# 70	1.4	28.85	2460	1170	2.00	36.35	4090	2800
	# 95	1.6	33.30	3360	1560	2.00	40.60	5200	3400
	# 120	1.6	36.90	4070	1800	2.00	43.45	6070	3800
	# 150	1.8	40.00	5020	2220	2.50	47.75	7260	4460
	# 185	2.0	44.80	6170	2650	2.50	52.05	8520	5000
	# 240	2.2	50.10	8080	3490	2.50	57.85	10790	6200
	# 300	2.4	55.60	10370	4610	2.50	63.25	13040	7280
# 400	2.6	62.20	12860	5490	2.50	69.85	16020	8650	
F O U R C O R E	* 1.5	0.6	-	190	-	0.90	14.20	390	-
	* 2.5	0.7	-	340	-	0.90	15.15	440	-
	* 4.0	0.8	-	380	-	1.25	17.80	710	-
	* 6.0	0.8	-	420	-	1.25	19.20	850	-
	* 10	1.0	-	700	-	1.25	22.80	1200	-
	* 16	1.0	20.70	920	520	1.60	26.30	1620	1220
	* 25	1.2	24.00	1290	660	1.60	30.70	2150	1520
	# 35	1.2	25.90	1690	800	1.60	30.30	2670	1780
	# 50	1.4	29.20	2250	1050	2.00	36.35	3880	2680
	# 70	1.4	33.00	3110	1390	2.00	39.95	4940	3220
	# 95	1.6	38.30	4280	1880	2.00	44.80	5900	3500
	# 120	1.6	41.80	5250	2230	2.50	49.30	7570	4550
	# 150	1.8	46.30	6530	2810	2.50	53.60	9060	5340
	# 185	2.0	51.30	8130	3340	2.50	59.00	10600	5910
	# 240	2.2	58.00	10460	4350	2.50	65.70	13690	7580
	# 300	2.4	64.60	13460	5790	2.50	72.00	16930	9260
# 400	2.6	72.00	16930	7100	3.15	81.30	21480	11650	

\* Circular/Circular Compacted Stranded Conductors

# Shaped Stranded Conductors

# Dimensions & Weights

Table 5

## PVC Insulated Power Cables

600 / 1000 V Unarmoured and single wire armoured, PVC over-sheathed cables.

BS 6346

Nominal Area of Conductor	Nominal Area of Neutral Conductor	Nominal Thickness of Insulation		Unarmoured				Armoured			
				Approx. Cable Diameter overall	Approximate Cable weight		Armour Wire Diameter	Approx. Cable Diameter overall	Approximate Cable weight		
					Copper	Aluminium			Copper	Aluminium	
mm <sup>2</sup>	mm <sup>2</sup>	Phase	Neutral	mm	kg / km		mm	mm	kg / km		
FOUR CORE WITH REDUCED NEUTRAL CONDUCTOR	* 25	* 16	1.2	1.0	24.90	1190	620	1.6	29.70	2020	1450
	# 35	* 16	1.2	1.0	24.95	1520	760	1.6	30.25	2430	1670
	# 50	* 25	1.4	1.2	28.60	2070	1010	1.6	33.90	3050	1990
	# 70	* 35	1.4	1.2	32.25	2830	1320	2.0	39.75	4220	2706
	# 95	* 50	1.6	1.4	37.50	3870	1770	2.0	44.80	6000	3900
	# 120	* 70	1.6	1.4	41.40	4820	2120	2.5	49.00	7180	4480
	# 150	* 70	1.8	1.4	44.70	5800	2570	2.5	52.45	8370	5140
	# 185	* 95	2.0	1.6	49.90	7400	3280	2.5	57.30	9910	5790
	# 240	* 120	2.2	1.6	56.00	9400	4060	2.5	64.25	12470	7130
	# 300	* 150	2.4	1.8	62.20	11910	5220	2.5	70.15	15080	8390
	# 300	* 185	2.4	2.0	64.20	12190	5270	2.5	71.80	15360	8440
	# 400	* 185	2.6	2.0	69.60	15070	6540	3.15	79.15	19470	10940

\* Circular/Circular Compacted Stranded Conductors

# Shaped Stranded Conductors



# Dimensions & Weights

Table 6

## XLPE Insulated Power Cables

600 / 1000 V Unarmoured and single wire armoured, PVC over-sheathed cables.

IEC 60502-1

Nominal Area of Conductor	Nominal Thickness of Insulation	Unarmoured				Armoured			
		Approx. Cable Diameter overall	Approximate Cable weight		Armour Wire Diameter	Approx. Cable Diameter overall	Approximate Cable weight		
			Copper	Aluminium			Copper	Aluminium	
mm <sup>2</sup>	mm	mm	kg / km		mm	mm	kg / km		
S I N G L E C O R E	* 1.5	0.7	7.80	50	-	-	-	-	-
	* 2.5	0.7	8.20	70	-	-	-	-	-
	* 4.0	0.7	8.70	90	-	-	-	-	-
	* 6.0	0.7	9.20	110	-	-	-	-	-
	* 10	0.7	10.10	160	-	-	-	-	-
	* 16	0.7	11.00	210	110	♦ 1.25	15.20	360	260
	* 25	0.9	12.00	320	160	♦ 1.25	16.10	480	320
	* 35	0.9	13.30	420	190	♦ 1.25	18.00	600	380
	* 50	1.0	14.30	540	240	♦ 1.25	19.20	790	490
	* 70	1.1	16.40	760	330	♦ 1.25	20.40	1030	600
	* 95	1.1	18.40	1030	430	♦ 1.25	22.60	1370	770
	* 120	1.2	20.30	1280	520	♦ 1.60	25.10	1660	900
	* 150	1.4	22.30	1560	630	♦ 1.60	26.80	1960	1030
	* 185	1.6	24.50	1940	770	♦ 1.60	29.10	2380	1210
	* 240	1.7	27.30	2460	930	♦ 1.60	32.20	3000	1470
	* 300	1.8	30.00	3150	1220	♦ 1.60	38.10	3660	1730
	^ 400	2.0	34.47	4160	1700	♦ 2.00	42.00	4730	2250
	^ 500	2.2	38.00	5040	1900	♦ 2.50	47.20	5840	2700
^ 630	2.4	43.50	6680	2680	♦ 2.50	53.00	7880	3880	
^ 800	2.6	48.70	8300	3110	♦ 2.50	57.90	9560	4360	
^ 1000	2.8	54.00	10400	3850	♦ 2.50	63.00	11800	5250	
T W O C O R E	* 1.5	0.7	11.50	-	-	0.90	14.30	280	-
	* 2.5	0.7	11.30	-	-	0.90	16.20	360	-
	* 4.0	0.7	12.00	-	-	0.90	17.00	460	-
	* 6.0	0.7	13.10	-	-	0.90	19.70	610	-
	* 10	0.7	15.00	-	-	1.25	21.50	870	-
	* 16	0.7	16.60	490	280	1.25	22.20	1110	900
	* 25	0.9	21.30	730	400	1.60	26.40	1470	1140
	# 35	0.9	21.70	960	500	1.60	25.30	1780	1320
	# 50	1.0	20.90	1120	510	1.60	26.10	1910	1300
	# 70	1.1	23.90	1550	670	1.60	29.50	2490	1610
	# 95	1.1	26.80	2100	870	2.00	33.60	3410	2180
	# 120	1.2	29.70	2630	1080	2.00	36.50	4050	2500
	# 150	1.4	33.10	3220	1320	2.00	39.70	4790	2890
	# 185	1.6	36.80	4010	1630	2.50	46.00	6190	3810
	# 240	1.7	41.30	5220	2090	2.50	50.50	7640	4510
	# 300	1.8	45.30	6480	2550	2.50	54.90	9200	5270
# 400	2.0	51.00	8320	3260	2.50	60.60	11360	6300	

- \* Circular/Circular Compacted Stranded Conductors
- # Shaped Stranded Conductors
- ♦ Aluminium Wire Armoured
- ^ Circular Stranded Conductor

## Dimensions & Weights

Table 7

### XLPE Insulated Power Cables

600 / 1000 V Unarmoured and single wire armoured, PVC over-sheathed cables.

IEC 60502-1

Nominal Area of Conductor	Nominal Thickness of Insulation	Unarmoured				Armoured			
		Approx. Cable Diameter overall	Approximate Cable weight		Armour Wire Diameter	Approx. Cable Diameter overall	Approximate Cable weight		
			Copper	Aluminium			Copper	Aluminium	
mm <sup>2</sup>	mm	mm	kg / km		mm	mm	kg / km		
T H R E E C O R E	* 1.5	0.7	11.10	140	-	0.90	15.90	380	-
	* 2.5	0.7	11.80	150	-	0.90	16.00	440	-
	* 4.0	0.7	12.70	240	-	0.90	17.50	530	-
	* 6.0	0.7	13.90	320	-	0.90	18.80	630	-
	* 10	0.7	15.90	460	-	1.25	21.20	940	-
	* 16	0.7	17.60	650	340	1.25	23.20	1300	990
	* 25	0.9	21.30	960	480	1.60	26.50	1720	1240
	# 35	0.9	21.40	1210	550	1.60	28.30	2000	1340
	# 50	1.0	23.30	1590	690	1.60	30.50	2450	1550
	# 70	1.1	26.80	2240	940	2.00	34.50	3250	1950
	# 95	1.1	30.50	2910	1090	2.00	39.40	4620	2800
	# 120	1.2	33.90	3790	1470	2.00	42.60	6180	3860
	# 150	1.4	38.00	4680	1840	2.50	48.00	7100	4260
	# 185	1.6	42.50	5880	2320	2.50	52.40	8780	5220
# 240	1.7	47.10	7600	2920	2.50	57.20	10680	6000	
# 300	1.8	52.50	9710	3950	2.50	62.30	11920	6160	
# 400	2.0	58.40	12390	4790	2.50	69.70	15940	8340	
F O U R C O R E	* 1.5	0.7	12.00	170	-	0.90	16.90	420	-
	* 2.5	0.7	12.90	220	-	0.90	17.80	500	-
	* 4.0	0.7	13.70	300	-	0.90	17.60	600	-
	* 6.0	0.7	15.10	390	-	1.25	20.00	840	-
	* 10	0.7	16.90	590	-	1.25	22.20	1200	-
	* 16	0.7	19.50	860	430	1.60	24.60	1650	1220
	* 25	0.9	22.90	1200	560	1.60	28.10	2460	1820
	# 35	0.9	23.80	1660	770	1.60	30.80	2540	1900
	# 50	1.0	27.10	2180	960	1.60	32.70	3100	2000
	# 70	1.1	33.10	3040	1330	2.00	41.00	4900	3190
	# 95	1.1	34.50	4160	1720	2.00	43.50	6390	3950
	# 120	1.2	38.50	5040	2150	2.50	49.00	7520	4630
	# 150	1.4	42.60	6420	2620	2.50	53.30	8600	4800
	# 185	1.6	47.40	8030	3280	2.50	58.50	10430	5680
# 240	1.7	53.70	10430	4180	2.50	63.90	13120	6870	
# 300	1.8	59.00	13010	5150	2.50	69.50	16370	8510	
# 400	2.0	66.70	16650	6520	3.15	78.70	21660	11530	

\* Circular/Circular Compacted Stranded Conductors

# Shaped Stranded Conductors



## Dimensions & Weights

Table 8

### XLPE Insulated Power Cables

600 / 1000 V Unarmoured and single wire armoured, PVC over-sheathed cables.

IEC 60502-1

Nominal Area of Conductor	Nominal Area of Neutral Conductor	Nominal Thickness of Insulation		Unarmoured				Armoured			
				Approx. Cable Diameter overall	Approximate Cable weight		Armour Wire Diameter	Approx. Cable Diameter overall	Approximate Cable weight		
					Copper	Aluminium			Copper	Aluminium	
mm <sup>2</sup>	mm <sup>2</sup>	mm		mm	kg / km		mm	mm	kg / km		
FOUR CORE WITH REDUCED NEUTRAL CONDUCTOR	* 25	* 16	0.9	0.7	23.70	1120	550	1.60	29.50	1880	1310
	# 35	* 16	0.9	0.7	24.10	1440	680	1.60	30.50	2280	1520
	# 50	* 25	1.0	0.9	27.10	1890	830	1.60	33.70	2960	1900
	# 70	* 35	1.1	0.9	31.70	2640	1110	2.00	39.50	4330	2800
	# 95	* 50	1.1	1.0	35.80	3970	1870	2.00	43.70	5950	3850
	# 120	* 70	1.2	1.1	39.90	4570	2010	2.50	48.60	6740	4180
	# 150	* 70	1.4	1.1	44.40	5470	2240	2.50	53.00	7680	440
	# 185	* 95	1.6	1.1	49.40	6890	2770	2.50	58.00	9650	5530
	# 240	* 120	1.7	1.2	55.80	9330	3990	2.50	64.50	11370	6030
	# 300	* 150	1.8	1.4	61.70	12540	4650	2.50	69.80	16020	8130
	# 400	* 185	2.0	1.6	68.80	14580	5830	2.50	79.30	19700	10950

\* Circular/Circular Compacted Stranded Conductors

# Shaped Stranded Conductors

## Current Carrying Capacity and Voltage Drop

Current Carrying Capacity and Voltage Drop of Cables mentioned in this catalogue are taken from BS 7671, 17th Edition of IEE Wiring Regulations. Appendix 4 of BS 7671 may be referred to for details on methods of Installation and Overload Protection.

**TABLE 4D1A — Single-core 70°C PVC Insulated cables, non-armoured with or without sheath (COPPER CONDUCTORS)**



**CURRENT-CARRYING CAPACITY [amperes]:**

Ambient temperature: 30°C  
Conductor operating temperature: 70°C

Conductor cross-sectional area	Reference Method B (enclosed in conduit on a wall or in trunking etc.)		Reference Method C (clipped direct)		Reference Method F (in free air or on a perforated cable tray horizontal or vertical)					
	2 cables, single-phase a.c. or d.c.	3 or 4 cables, three-phase a.c.	2 cables, single-phase a.c. or d.c. flat and touching	3 or 4 cables, three-phase a.c. flat and touching or trefoil	Touching			Spaced By one diameter		
					2 cables, single-phase a.c. or d.c. flat	3 cables, three-phase a.c. flat	3 cables, three-phase a.c. trefoil	2 Cables, single-phase a.c. or d.c. or 3 cables three-phase a.c. flat	Horizontal	Vertical
1	2	3	4	5	6	7	8	9	10	
[mm <sup>2</sup> ]	[A]	[A]	[A]	[A]	[A]	[A]	[A]	[A]	[A]	[A]
16	76	68	87	79	-	-	-	-	-	
25	101	89	114	104	131	114	110	146	130	
35	125	110	141	129	162	143	137	181	162	
50	151	134	182	167	196	174	167	219	197	
70	192	171	234	214	251	225	216	281	254	
95	232	207	284	261	304	275	264	341	311	
120	269	239	330	303	352	321	308	396	362	
150	300	262	381	349	406	372	356	456	419	
185	341	296	436	400	463	427	409	521	480	
240	400	346	515	472	546	507	485	615	569	
300	458	394	594	545	629	587	561	709	659	
400	546	467	694	634	754	689	656	852	795	
500	626	533	792	723	868	789	749	982	920	
630	720	611	904	826	1005	905	855	1138	1070	
800	-	-	1030	943	1086	1020	971	1265	1188	
1000	-	-	1154	1058	1216	1149	1079	1420	1337	



**TABLE 4D2A — Multi-core 70°C PVC Insulated and Sheathed cables, non-armoured (COPPER CONDUCTORS)**



Ambient temperature: 30°C  
Conductor operating temperature: 70°C

**CURRENT-CARRYING CAPACITY (amperes):**

Conductor cross-sectional area	Reference Method B (enclosed in conduit on a wall or in trunking etc.)		Reference Method C (clipped direct)		Reference Method E (in free air or on a perforated cable tray etc. horizontal or vertical)	
	1 two—core cable,* single-phase a.c. or d.c.	1 three-core cable,* or 1 four-core cable, three-phase a.c.	1 two—core cable,* single-phase a.c. or d.c.	1 three-core cable,* or 1 four-core cable, three-phase a.c.	1 two—core cable,* single phase a.c. or d.c.	1 three-core cable,* or 1 four-core cable, three-phase a.c.
1	2	3	4	5	6	7
[mm <sup>2</sup> ]	[A]	[A]	[A]	[A]	[A]	[A]
16	69	62	85	76	94	80
25	90	80	112	96	119	101
35	111	99	138	119	148	126
50	133	118	168	144	180	153
70	168	149	213	184	232	196
95	201	179	258	223	282	238
120	232	206	299	259	328	276
150	258	225	344	299	379	319
185	294	255	392	341	434	364
240	344	297	461	403	514	430
300	394	339	530	464	593	497
400	470	402	634	557	715	597

\* with or without a protective conductor

**TABLE 4D2B – Multi-core 70°C PVC Insulated and Sheathed cables, non-armoured (COPPER CONDUCTORS)**



**VOLTAGE DROP (per ampere per metre):**

Conductor operating temperature: 70°C

Conductor cross-sectional area 1	Two-core cable, d.c.	Two-core cable, single-phase a.c.			Three or four-core cable, Three-phase a.c.		
	2	3			4		
(mm <sup>2</sup> )	(mV/A/m)	(mV/A/m)			(mV/A/m)		
16	2.8	2.8			2.4		
		r	x	z	r	x	z
25	1.75	1.75	0.170	1.75	1.50	0.145	1.50
35	1.25	1.25	0.165	1.25	1.10	0.145	1.10
50	0.93	0.93	0.165	0.94	0.80	0.140	0.81
70	0.63	0.63	0.160	0.65	0.55	0.140	0.57
95	0.46	0.47	0.155	0.50	0.41	0.135	0.43
120	0.36	0.38	0.155	0.41	0.33	0.135	0.35
150	0.29	0.30	0.155	0.34	0.26	0.130	0.29
185	0.23	0.25	0.150	0.29	0.21	0.130	0.25
240	0.180	0.190	0.150	0.24	0.165	0.130	0.21
300	0.145	0.155	0.145	0.21	0.135	0.130	0.185
400	0.105	0.115	0.145	0.185	0.100	0.125	0.160

**TABLE 4D3A – Single-core 70°C armoured PVC Insulated and Sheathed cables, Aluminium wire armour (COPPER CONDUCTORS)**



**CURRENT-CARRYING CAPACITY (amperes):**

Ambient temperature: 30°C  
Conductor operating temperature: 70°C

Conductor cross-sectional area	Reference Method C (clipped direct)		Reference Method F (in free air or on a perforated cable tray, horizontal or vertical)								
	Touching		Touching			Spaced by one cable diameter					
	2 cables, single-phase a.c. or d.c. flat	3 or 4 cables, three-phase a.c. flat	2 cables, single-phase a.c. or d.c. flat	3 cables, three-phase a.c. flat	3 cables, three-phase a.c. trefoil	2 cables, d.c.		2 cables, single-phase a.c.		3 or 4 cables, three-phase a.c.	
						Horizontal	Vertical	Horizontal	Vertical	Horizontal	Vertical
1	2	3	4	5	6	7	8	9	10	11	12
(mm <sup>2</sup> )	(A)	(A)	(A)	(A)	(A)	(A)	(A)	(A)	(A)	(A)	(A)
50	193	179	205	189	181	229	216	229	217	230	212
70	245	225	259	238	231	294	279	287	272	286	263
95	296	269	313	285	280	357	340	349	332	338	313
120	342	309	360	327	324	415	396	401	383	385	357
150	393	352	413	373	373	479	458	449	429	436	405
185	447	399	469	422	425	548	525	511	489	490	456
240	525	465	550	492	501	648	622	593	568	566	528
300	594	515	624	547	567	748	719	668	640	616	578
400	687	575	723	618	657	885	851	737	707	674	632
500	763	622	805	673	731	1035	997	810	777	721	676
630	843	669	891	728	809	1218	1174	893	856	771	723
800	919	710	976	777	886	1441	1390	943	905	824	772
1000	975	737	1041	808	945	1685	1627	1008	967	872	816

**TABLE 4D3B — Single-core 70°C armoured PVC Insulated and Sheathed cables, Aluminium wire armour (COPPER CONDUCTORS)**



**VOLTAGE DROP (per ampere per metre):**

Conductor operating temperature: 70°C

Conductor cross-sectional area 1	2 Cables d.c. 2	Reference Methods C & F (clipped direct, on tray or free air)														
		2 cables, single-phase a.c.						3 or 4 cables, three-phase a.c.								
		Touching 3			Spaced* 4			Trefoil and touching 5			Flat and touching 6			Flat and spaced* 7		
(mm <sup>2</sup> )	(mV/A/m)	(mV/A/m)			(mV/A/m)			(mV/A/m)			(mV/A/m)			(mV/A/m)		
		r	x	z	r	x	z	r	x	z	r	x	z	r	x	z
50	0.93	0.93	0.22	0.95	0.92	0.30	0.97	0.80	0.190	0.82	0.79	0.26	0.84	0.79	0.34	0.86
70	0.63	0.64	0.21	0.68	0.66	0.29	0.72	0.56	0.180	0.58	0.57	0.25	0.62	0.59	0.32	0.68
95	0.46	0.48	0.20	0.52	0.51	0.28	0.58	0.42	0.175	0.45	0.44	0.25	0.50	0.47	0.31	0.57
120	0.36	0.39	0.195	0.43	0.42	0.28	0.50	0.33	0.170	0.37	0.36	0.24	0.43	0.40	0.30	0.50
150	0.29	0.31	0.190	0.37	0.34	0.27	0.44	0.27	0.165	0.32	0.30	0.24	0.38	0.34	0.30	0.45
185	0.23	0.26	0.190	0.32	0.29	0.27	0.39	0.22	0.160	0.27	0.25	0.23	0.34	0.29	0.29	0.41
240	0.180	0.20	0.180	0.27	0.23	0.26	0.35	0.175	0.160	0.23	0.20	0.23	0.30	0.24	0.28	0.37
300	0.145	0.160	0.180	0.24	0.190	0.26	0.32	0.140	0.155	0.21	0.165	0.22	0.28	0.20	0.28	0.34
400	0.105	0.140	0.175	0.22	0.180	0.24	0.30	0.120	0.130	0.195	0.160	0.21	0.26	0.21	0.25	0.32
500	0.086	0.120	0.170	0.21	0.165	0.23	0.29	0.105	0.145	0.180	0.145	0.20	0.25	0.190	0.24	0.30
630	0.068	0.105	0.165	0.195	0.150	0.22	0.27	0.091	0.145	0.170	0.135	0.195	0.23	0.175	0.22	0.28
800	0.053	0.095	0.160	0.185	0.145	0.21	0.25	0.082	0.140	0.160	0.125	0.180	0.22	0.170	0.195	0.26
1000	0.042	0.091	0.155	0.180	0.140	0.190	0.24	0.079	0.135	0.155	0.125	0.165	0.21	0.165	0.170	0.24

Note: \* Spacings larger than one cable diameter will result in a larger voltage drop.

**TABLE 4D4A — Multi-core 70°C armoured PVC Insulated and Sheathed cables, (COPPER CONDUCTORS)**



Air Ambient temperature: 30°C  
 Ground ambient temperature: 20°C  
 Conductor operating temperature: 70°C

**CURRENT-CARRYING CAPACITY [amperes]:**

Conductor cross-sectional area 1	Reference Method C (clipped direct)		Reference Method E (in free air or on a perforated cable tray etc. horizontal or vertical)		Reference Method D (direct in ground or in ducting in ground, in or around buildings)	
	1 two—core cable, single-phase a.c. or d.c. 2	1 three or four-core cable, three-phase a.c. 3	1 two—core cable, single-phase a.c. or d.c. 4	1 three or four-core cable, three-phase a.c. 5	1 two—core cable, single-phase a.c. or d.c. 6	1 three or four-core cable, three-phase a.c. 7
(mm <sup>2</sup> )	(A)	(A)	(A)	(A)	(A)	(A)
1.5	21	18	22	19	22	18
2.5	28	25	31	26	29	24
4	38	33	41	35	37	30
6	49	42	53	45	46	38
10	67	58	72	62	60	50
16	89	77	97	83	78	64
25	118	102	128	110	99	82
35	145	125	157	135	119	98
50	175	151	190	163	140	116
70	222	192	241	207	173	143
95	269	231	291	251	204	169
120	310	267	336	290	231	192
150	356	306	386	332	261	217
185	405	348	439	378	292	243
240	476	409	516	445	336	280
300	547	469	592	510	379	316
400	621	540	683	590	-	-

**TABLE 4D4B — Multi-core 70°C armoured PVC Insulated and Sheathed cables, [COPPER CONDUCTORS]**



**VOLTAGE DROP (per ampere per metre):**

Conductor operating temperature: 70°C

Conductor cross-sectional area 1	Two-core cable, d.c.	Two-core cable, single-phase a.c.			Three or four-core cable, Three-phase a.c.		
	2	3			4		
(mm <sup>2</sup> )	(mV/A/m)	(mV/A/m)			(mV/A/m)		
1.5	29	29			25		
2.5	18	18			15		
4	11	11			9.5		
6	7.3	7.3			6.4		
10	4.4	4.4			3.8		
16	2.8	2.8			2.4		
		r	x	z	r	x	z
25	1.75	1.75	0.170	1.75	1.50	0.145	1.50
35	1.25	1.25	0.165	1.25	1.10	0.145	1.10
50	0.93	0.93	0.165	0.94	0.80	0.140	0.81
70	0.63	0.63	0.160	0.65	0.55	0.140	0.57
95	0.46	0.47	0.155	0.50	0.41	0.135	0.43
120	0.36	0.38	0.155	0.41	0.33	0.135	0.35
150	0.29	0.30	0.155	0.34	0.26	0.130	0.29
185	0.23	0.25	0.150	0.29	0.21	0.130	0.25
240	0.180	0.190	0.150	0.24	0.165	0.130	0.21
300	0.145	0.155	0.145	0.21	0.135	0.130	0.185
400	0.105	0.115	0.145	0.185	0.100	0.125	0.160

**TABLE 4H1A — Single-core 70°C PVC Insulated cables, non-armoured with or without sheath (ALUMINIUM CONDUCTORS)**



**CURRENT-CARRYING CAPACITY (amperes):**

Ambient temperature: 30°C  
Conductor operating temperature: 70°C

Conductor cross-sectional area	Reference Method B (enclosed in conduit on a wall or in trunking etc.)		Reference Method C (clipped direct)		Reference Method F (in free air or on a perforated cable tray, horizontal or vertical)					
	2 cables, single-phase a.c. or d.c.	3 or 4 cables, three-phase a.c.	2 cables, single-phase a.c. or d.c. flat and touching	3 or 4 cables, three-phase a.c. flat and touching or trefoil	Touching			Spaced by one diameter		
					2 cables, single-phase a.c. or d.c. flat	3 cables, three-phase a.c. flat	3 cables, three-phase a.c. foil	2 Cables, single-phase a.c. or d.c. or 3 cables three-phase a.c. flat		
	1	2	3	4	5	6	7	8	Horizontal 9	Vertical 10
[mm <sup>2</sup> ]	(A)	(A)	(A)	(A)	(A)	(A)	(A)	(A)	(A)	(A)
50	118	104	125	110	149	133	128	169	152	
70	150	133	160	140	192	173	166	217	196	
95	181	161	195	170	235	212	203	265	241	
120	210	186	226	197	273	247	237	308	282	
150	234	204	261	227	316	287	274	356	327	
185	266	230	298	259	363	330	316	407	376	
240	312	269	352	305	430	392	375	482	447	
300	358	306	406	351	497	455	434	557	519	

Table 18

**TABLE 4H1B — Single-core 70°C PVC Insulated cables, non-armoured with or without sheath (ALUMINIUM CONDUCTORS)**



**VOLTAGE DROP (per ampere per metre):**

Conductor operating temperature: 70°C

Conductor cross-sectional area 1	2 Cables, d.c. 2	2 cables, single-phase a.c.									3 or 4 cables, three-phase a.c.											
		Reference Method B (enclosed in conduit or trunking)			Reference Methods C & F (clipped direct, on tray or in free air)						Reference Method B (enclosed in conduit or trunking)			Reference Methods C & F (clipped direct, on tray or in free air),								
		3			4 Cables touching			5 Cables spaced*			6			7 Cables touching, Trefoil			8 Cables touching, Flat			9 Cables spaced*, Flat		
(mm <sup>2</sup> )	(mV/A/m)	(mV/A/m)			(mV/A/m)			(mV/A/m)			(mV/A/m)			(mV/A/m)			(mV/A/m)					
		r	x	z	r	x	z	r	x	z	r	x	z	r	x	z	r	x	z	r	x	z
50	1.55	1.60	0.30	1.60	1.55	0.190	1.55	1.55	0.28	1.55	1.35	0.26	1.40	1.35	0.165	1.35	1.35	0.24	1.35	1.35	0.32	1.40
70	1.05	1.10	0.30	1.15	1.05	0.185	1.05	1.05	0.27	1.10	0.94	0.26	0.97	0.91	0.160	0.92	0.91	0.24	0.94	0.91	0.31	0.96
95	0.77	0.81	0.29	0.86	0.77	0.185	0.79	0.77	0.27	0.82	0.70	0.25	0.74	0.67	0.160	0.69	0.67	0.23	0.71	0.67	0.31	0.74
120	0.61	0.64	0.29	0.70	0.61	0.180	0.64	0.61	0.27	0.67	0.55	0.25	0.61	0.53	0.155	0.55	0.53	0.23	0.58	0.53	0.31	0.61
150	0.49	0.51	0.28	0.59	0.49	0.175	0.52	0.49	0.26	0.55	0.45	0.24	0.51	0.42	0.155	0.45	0.42	0.23	0.48	0.42	0.30	0.52
185	0.39	0.42	0.28	0.50	0.40	0.175	0.43	0.39	0.26	0.47	0.36	0.24	0.44	0.34	0.150	0.37	0.34	0.23	0.41	0.34	0.30	0.46
240	0.30	0.32	0.27	0.42	0.30	0.170	0.35	0.30	0.26	0.40	0.28	0.24	0.37	0.26	0.150	0.30	0.26	0.22	0.35	0.26	0.30	0.40
300	0.24	0.26	0.27	0.37	0.24	0.170	0.30	0.24	0.26	0.35	0.23	0.23	0.32	0.21	0.145	0.26	0.21	0.22	0.31	0.21	0.30	0.36

Note: \*Spacing larger than one cable diameter will result in a larger voltage drop.

**TABLE 4H2A — Multi-core 70°C PVC Insulated and Sheathed cables, non-armoured (ALUMINIUM CONDUCTORS)**



Ambient temperature: 30°C  
 Conductor operating temperature: 70°C

**CURRENT-CARRYING CAPACITY (amperes):**

Conductor cross-sectional area 1	Reference Method B (enclosed in conduit on a wall or in trunking etc.)		Reference Method C (clipped direct)		Reference Method E (in free air or on a perforated cable tray etc, horizontal or vertical)	
	1 two-core cable, single-phase a.c. or d.c. 2	1 three or four-core cable, three-phase a.c. 3	1 two-core cable, single-phase a.c. or d.c. 4	1 three or four-core cable, three-phase a.c. 5	1 two-core cable, single-phase a.c. or d.c. 6	1 three or four-core cable, three-phase a.c. 7
(mm <sup>2</sup> )	[A]	[A]	[A]	[A]	[A]	[A]
16	54	48	66	59	73	61
25	71	62	83	73	89	78
35	86	77	103	90	111	96
50	104	92	125	110	135	117
70	131	116	160	140	173	150
95	157	139	195	170	210	183
120	-	160	-	197	-	212
150	-	176	-	227	-	245
185	-	199	-	259	-	280
240	-	232	-	305	-	330
300	-	265	-	351	-	381

**TABLE 4H2B — Multi-core 70°C PVC Insulated and Sheathed cables, non-armoured (ALUMINIUM CONDUCTORS)**



**VOLTAGE DROP (per ampere per metre):**

Conductor operating temperature: 70°C

Conductor cross-sectional area 1	Two-core cable, d.c. 2	Two-core cable, single-phase a.c. 3			Three or four-core cable, Three-phase a.c. 4		
(mm <sup>2</sup> )	(mV/A/m)	(mV/A/m)			(mV/A/m)		
16	4.5	4.5			3.9		
		r	x	z	r	x	z
25	2.9	2.9	0.175	2.9	2.5	0.150	2.5
35	2.1	2.1	0.170	2.1	1.80	0.150	1.80
50	1.55	1.55	0.170	1.55	1.35	0.145	1.35
70	1.05	1.05	0.165	1.05	0.90	0.140	0.92
95	0.77	0.77	0.160	0.79	0.67	0.140	0.68
120	-	-	-	-	0.53	0.135	0.55
150	-	-	-	-	0.42	0.135	0.44
185	-	-	-	-	0.34	0.135	0.37
240	-	-	-	-	0.26	0.130	0.30
300	-	-	-	-	0.21	0.130	0.25

**TABLE 4H3A — Single-core 70°C armoured Insulated and PVC Sheathed cables, Aluminium wire armour (ALUMINIUM CONDUCTORS)**



**CURRENT-CARRYING CAPACITY (amperes):**

Ambient temperature: 30°C  
Conductor operating temperature: 70°C

Conductor cross-sectional area	Reference Method C (clipped direct)		Reference Method F (in free air or on a perforated cable tray, horizontal or vertical)								
	Touching		Touching			Spaced by one cable diameter					
	2 cables, single-phase a.c. or d.c. flat	3 or 4 cables, three-phase a.c. flat	2 cables, single-phase a.c. or d.c. flat	3 cables, three-phase a.c. flat	3 cables, three-phase a.c. trefoil	2 cables, d.c.		2 cables, single-phase a.c.		3 or 4 cables, three-phase a.c.	
						Horizontal	Vertical	Horizontal	Vertical	Horizontal	Vertical
1	2	3	4	5	6	7	8	9	10	11	12
[mm <sup>2</sup> ]	[A]	[A]	[A]	[A]	[A]	[A]	[A]	[A]	[A]	[A]	[A]
50	143	133	152	141	131	167	157	168	159	169	155
70	183	168	194	178	168	214	202	212	200	213	196
95	221	202	234	214	205	261	247	259	245	255	236
120	255	233	270	246	238	303	288	299	285	293	272
150	294	267	310	282	275	349	333	340	323	335	312
185	334	303	352	319	315	400	382	389	371	379	354
240	393	354	413	374	372	472	452	457	437	443	415
300	452	405	474	427	430	545	523	520	498	505	475

**TABLE 4H3B — Single-core 70°C armoured PVC Insulated and Sheathed cables, Aluminium wire armour (ALUMINIUM CONDUCTORS)**

**VOLTAGE DROP (per ampere per metre):**

Conductor operating temperature: 70°C

Conductor cross-sectional area 1	2 Cables d.c. 2	Reference Methods C & F (clipped direct, on tray or in free air)														
		2 cables, single-phase a.c.						3 or 4 cables, three-phase a.c.								
		Touching 3			Spaced* 4			Trefoil and touching 5			Flat and touching 6			Flat and spaced* 7		
[mm <sup>2</sup> ]	[mV/ A/m]	[mV/ A/m]			[mV/ A/m]			[mV/ A/m]			[mV/ A/m]			[mV/ A/m]		
		r	x	z	r	x	z	r	x	z	r	x	z	r	x	z
50	1.55	1.55	0.23	1.55	1.55	0.31	1.55	1.35	0.195	1.35	1.35	0.27	1.35	1.30	0.34	1.35
70	1.05	1.05	0.22	1.10	1.05	0.30	1.10	0.92	0.190	0.93	0.93	0.26	0.96	0.95	0.33	1.00
95	0.77	0.78	0.21	0.81	0.81	0.29	0.86	0.68	0.185	0.70	0.70	0.25	0.75	0.73	0.32	0.80
120	0.61	0.62	0.21	0.66	0.65	0.29	0.71	0.54	0.180	0.57	0.57	0.25	0.62	0.60	0.32	0.68
150	0.49	0.50	0.20	0.54	0.53	0.28	0.60	0.44	0.175	0.47	0.44	0.24	0.52	0.50	0.31	0.58
185	0.39	0.41	0.195	0.45	0.44	0.28	0.52	0.35	0.170	0.39	0.38	0.24	0.45	0.42	0.30	0.51
240	0.30	0.32	0.190	0.37	0.34	0.27	0.44	0.28	0.165	0.32	0.30	0.23	0.38	0.33	0.29	0.44
300	0.24	0.26	0.185	0.32	0.28	0.26	0.39	0.22	0.160	0.27	0.24	0.23	0.34	0.28	0.29	0.40

Note: \* Spacings larger than one cable diameter will result in a larger voltage drop.

**TABLE 4H4A — Multi-core 70°C armoured PVC Insulated and Sheathed cables, (ALUMINIUM CONDUCTORS)**



Air Ambient temperature: 30°C  
 Ground ambient temperature: 20°C  
 Conductor operating temperature: 70°C

**CURRENT-CARRYING CAPACITY [amperes]:**

Conductor cross-sectional area 1	Reference Method C (clipped direct)		Reference Method E (in free air or on a perforated cable tray etc. horizontal or vertical)		Reference Method D (direct in ground or in ducting in ground, in or around buildings)	
	1 two-core cable, sing-phase a.c. or d.c. 2	1 three or 1 four-core cable, three-phase a.c. 3	1 two-core cable, sing-phase a.c. or d.c. 4	1 three or 1 four-core cable, three-phase a.c. 5	1 two-core cable, sing-phase a.c. or d.c. 6	1 three or 1 four-core cable, three-phase a.c. 7
[mm <sup>2</sup> ]	[A]	[A]	[A]	[A]	[A]	[A]
16	68	58	71	61		
25	89	76	94	80	77	64
35	109	94	115	99	93	77
50	131	113	139	119	109	91
70	165	143	175	151	135	112
95	199	174	211	186	159	132
120	-	202	-	216	-	150
150	-	232	-	250	-	169
185	-	265	-	287	-	190
240	-	312	-	342	-	218
300	-	360	-	399	-	247

**TABLE 4H4B — Multi-core 70°C armoured PVC Insulated and Sheathed cables, (ALUMINIUM CONDUCTORS)**

**VOLTAGE DROP (per ampere per metre):**

Conductor operating temperature: 70°C

Conductor cross-sectional area 1	Two-core cable, d.c.	Two-core cable, single-phase a.c.			Three or four-core cable, three-phase a.c.		
	2	3			4		
(mm <sup>2</sup> )	(mV/A/m)	(mV/A/m)			(mV/A/m)		
16	4.5						
		r	x	z	r	x	z
25	2.9	2.9	0.175	2.9	2.5	0.150	2.5
35	2.1	2.1	0.170	2.1	1.80	0.150	1.80
50	1.55	1.55	0.170	1.55	1.35	0.145	1.35
70	1.05	1.05	0.165	1.05	0.90	0.140	0.92
95	0.77	0.77	0.160	0.79	0.67	0.140	0.68
120	-	-	-	-	0.53	0.135	0.55
150	-	-	-	-	0.42	0.135	0.44
185	-	-	-	-	0.34	0.135	0.37
240	-	-	-	-	0.26	0.130	0.30
300	-	-	-	-	0.21	0.130	0.25

**TABLE 4E1A — Single-core 90°C XLPE Insulated cables, unarmoured with or without PVC sheath (COPPER CONDUCTORS)**



**CURRENT-CARRYING CAPACITY (amperes):**

Ambient temperature: 30°C  
Conductor operating temperature: 90°C

Conductor cross-sectional area	Reference Method B (enclosed in conduit on a wall or in trunking etc.)		Reference Method C (clipped direct)		Reference Method F (in free air or on a perforated cable tray etc, Horizontal or vertical etc.) Touching			Reference Method G (in free air) Spaced By one cable diameter		
	2 cables, single-phase a.c. or d.c.	3 or 4 cables, three-phase a.c.	2 cables, single-phase a.c. or d.c flat and touching	3 or 4 cables, three-phase a.c. flat and touching or trefoil	2 cables, single-phase a.c. or d.c. flat	3 cables, three-phase a.c. flat	3 cables, three-phase a.c. trefoil	2 cables, single-phase a.c or d.c. or 3 cables three-phase a.c. flat		
	1	2	3	4	5	6	7	8	9	10
[mm <sup>2</sup> ]	(A)	(A)	(A)	(A)	(A)	(A)	(A)	(A)	(A)	(A)
1	17	15	19	17.5	-	-	-	-	-	-
1.5	23	20	25	23	-	-	-	-	-	-
2.5	31	28	34	31	-	-	-	-	-	-
4	42	37	46	41	-	-	-	-	-	-
6	54	48	59	54	-	-	-	-	-	-
10	75	66	81	74	-	-	-	-	-	-
16	100	88	109	99	-	-	-	-	-	-
25	133	117	143	130	161	141	135	182	161	
35	164	144	176	161	200	176	169	226	201	
50	198	175	228	209	242	216	207	275	246	
70	253	222	293	268	310	279	268	353	318	
95	306	269	355	326	377	342	328	430	389	
120	354	312	413	379	437	400	383	500	454	
150	393	342	476	436	504	464	444	577	527	
185	449	384	545	500	575	533	510	661	605	
240	528	450	644	590	679	634	607	781	719	
300	603	514	743	681	783	736	703	902	833	
400	683	584	868	793	940	868	823	1058	1008	
500	783	666	990	904	1083	998	946	1253	1169	
630	900	764	1130	1033	1254	1151	1088	1454	1362	
800	-	-	1288	1179	1358	1275	1214	1581	1485	
1000	-	-	1443	1323	1520	1436	1349	1775	1671	

**Notes:**

1. Where a conductor operates at a temperature exceeding 70°C it must be ascertained that the equipment connected to the conductor is suitable for the conductor operating temperature [see Regulation 512.1.2].
2. Where cables in this table are connected to equipment or accessories designed to operate at a temperature not exceeding 70°C, the current ratings given in the equivalent table for 70°C thermoplastic insulated cables (Table 4D1A) must be used [see also Regulation 523.1]

Table 26

**TABLE 4E1B — Single-core 90°C XLPE Insulated cables, unarmoured with or without PVC sheath (COPPER CONDUCTORS)**



**VOLTAGE DROP (per ampere per metre):**

Conductor operating temperature: 90°C

Conductor cross-sectional area 1	2 Cables d.c.	2 cables, single-phase a.c.						3 or 4 cables, three-phase a.c.														
		Reference Method B (enclosed in conduit or trunking)			Reference Methods C, F & G (clipped direct, on tray or in free air)			Reference Method B (enclosed in conduit or trunking)			Reference Methods C, F & G (clipped direct, on tray or in free air),											
					Cables touching	Cables spaced*					Cables touching, Trefoil			Cables touching, Flat			Cables spaced*, Flat					
1	2	3			4			5			6			7			8			9		
(mm <sup>2</sup> )	(mV/A/m)	(mV/A/m)			(mV/A/m)			(mV/A/m)			(mV/A/m)			(mV/A/m)			(mV/A/m)			(mV/A/m)		
1	46	46			46			46			40			40			40			40		
1.5	31	31			31			31			27			27			27			27		
2.5	19	19			19			19			16			16			16			16		
4	12	12			12			12			10			10			10			10		
6	7.9	7.9			7.9			7.9			6.8			6.8			6.8			6.8		
10	4.7	4.7			4.7			4.7			4.0			4.0			4.0			4.0		
16	2.9	2.9			2.9			2.9			2.5			2.5			2.5			2.5		
25	1.85	r	x	z	r	x	z	r	x	z	r	x	z	r	x	z	r	x	z	r	x	z
35	1.35	1.85	0.31	1.90	1.85	0.190	1.85	1.85	0.28	1.85	1.60	0.27	1.65	1.60	0.165	1.60	1.60	0.190	1.60	1.60	0.27	1.65
50	0.99	1.35	0.29	1.35	1.35	0.180	1.35	1.35	0.27	1.35	1.15	0.25	1.15	1.15	0.155	1.15	1.15	0.180	1.15	1.15	0.26	1.20
70	0.68	0.99	0.29	1.05	0.99	0.180	1.00	0.99	0.27	1.00	0.87	0.25	0.90	0.86	0.155	0.87	0.86	0.180	0.87	0.86	0.26	0.89
95	0.49	0.68	0.28	0.75	0.68	0.175	0.71	0.68	0.26	0.73	0.60	0.24	0.65	0.59	0.150	0.61	0.59	0.175	0.62	0.59	0.25	0.65
120	0.39	0.49	0.27	0.58	0.49	0.170	0.52	0.49	0.26	0.56	0.44	0.23	0.50	0.43	0.145	0.45	0.43	0.170	0.46	0.43	0.25	0.49
150	0.32	0.39	0.26	0.48	0.39	0.165	0.43	0.39	0.25	0.47	0.35	0.23	0.42	0.34	0.140	0.37	0.34	0.165	0.38	0.34	0.24	0.42
185	0.25	0.32	0.26	0.43	0.32	0.165	0.36	0.32	0.25	0.41	0.29	0.23	0.37	0.28	0.140	0.31	0.28	0.165	0.32	0.28	0.24	0.37
240	0.190	0.25	0.26	0.37	0.26	0.165	0.30	0.25	0.25	0.36	0.23	0.23	0.32	0.22	0.140	0.26	0.22	0.165	0.28	0.22	0.24	0.33
300	0.155	0.190	0.26	0.33	0.20	0.160	0.25	0.195	0.25	0.31	0.185	0.22	0.29	0.170	0.140	0.22	0.170	0.165	0.24	0.170	0.24	0.29
400	0.120	0.155	0.25	0.31	0.160	0.160	0.22	0.155	0.25	0.29	0.150	0.22	0.27	0.140	0.140	0.195	0.135	0.160	0.21	0.135	0.24	0.27
500	0.093	0.120	0.25	0.29	0.130	0.155	0.20	0.125	0.24	0.27	0.125	0.22	0.25	0.110	0.135	0.175	0.110	0.160	0.195	0.110	0.24	0.26
630	0.072	0.100	0.25	0.27	0.105	0.155	0.185	0.098	0.24	0.26	0.100	0.22	0.24	0.090	0.135	0.160	0.088	0.160	0.180	0.085	0.24	0.25
800	0.056	-	-	-	0.086	0.155	0.175	0.078	0.24	0.25	0.088	0.21	0.23	0.074	0.135	0.150	0.071	0.160	0.170	0.068	0.23	0.24
1000	0.045	-	-	-	0.072	0.150	0.170	0.064	0.24	0.25	0.062	0.130	0.145	0.059	0.130	0.140	0.059	0.155	0.165	0.055	0.23	0.24
		-	-	-	0.063	0.150	0.165	0.054	0.24	0.24	0.055	0.130	0.140	0.050	0.155	0.165	0.047	0.23	0.24			

Note: \*Spacings larger than one cable diameter will result in a larger voltage drop.

**TABLE 4E2A — Multi-core 90°C XLPE Insulated and PVC Sheathed cables, non-armoured (COPPER CONDUCTORS)**



Ambient temperature: 30°C  
Conductor operating temperature: 90°C

**CURRENT-CARRYING CAPACITY [amperes]:**

Conductor cross-sectional area	Reference Method B (enclosed in conduit on a wall or in trunking etc.)		Reference Method C (clipped direct)		Reference Method E (in free air or on a perforated cable tray etc. horizontal or vertical)	
	1 two-core cable*, single phase a.c. or d.c.	1 three or four-core cable*, three-phase a.c.	1 two-core cable*, single-phase a.c. or d.c.	1 three or four-core cable*, three-phase a.c.	1 two-core cable*, single-phase a.c. or d.c.	1 three or four-core cable*, three-phase a.c.
1	2	3	4	5	6	7
[mm <sup>2</sup> ]	[A]	[A]	[A]	[A]	[A]	[A]
1	17	15	19	17	21	18
1.5	22	19.5	24	22	26	23
2.5	30	26	33	30	36	32
4	40	35	45	40	49	42
6	51	44	58	52	63	54
10	69	60	80	71	86	75
16	91	80	107	96	115	100
25	119	105	138	119	149	127
35	146	128	171	147	185	158
50	175	154	209	179	225	192
70	221	194	269	229	289	246
95	265	233	328	278	352	298
120	305	268	382	322	410	346
150	334	300	441	371	473	399
185	384	340	506	424	542	456
240	459	398	599	500	641	538
300	532	455	693	576	741	621
400	625	536	803	667	865	741

\* with or without a protective conductor

**NOTES:**

1. Where a conductor operates at a temperature exceeding 70°C it must be ascertained that the equipment connected to the conductor is suitable for the conductor operating temperature [see Regulation 512.1.2].
2. Where cables in this table are connected to equipment or accessories designed to operate at a temperature not exceeding 70°C, the current ratings given in the equivalent table for 70°C thermoplastic insulated cables [Table 4D2A] must be used [see also Regulation 523.1].

**TABLE 4E2B — Multicore 90°C XLPE insulated and PVC sheathed cables, non-armoured (COPPER CONDUCTORS)**

**VOLTAGE DROP (per ampere per metre):**

Conductor operating temperature: 90°C

Conductor cross-sectional area 1	Two-core cable, d.c.	Two-core cable, single-phase a.c.			Three or four-core cable, Three-phase a.c.		
	2	3			4		
[mm <sup>2</sup> ]	[mV/A/m]	[mV/A/m]			[mV/A/m]		
1	46	46			40		
1.5	31	31			27		
2.5	19	19			16		
4	12	12			10		
6	7.9	7.9			6.8		
10	4.7	4.7			4.0		
16	2.9	2.9			2.5		
		r	x	z	r	x	z
25	1.85	1.85	0.160	1.90	1.60	0.140	1.65
35	1.35	1.35	0.155	1.35	1.15	0.135	1.15
50	0.98	0.99	0.155	1.00	0.86	0.135	0.87
70	0.67	0.67	0.150	0.69	0.59	0.130	0.60
95	0.49	0.50	0.150	0.52	0.43	0.130	0.45
120	0.39	0.40	0.145	0.42	0.34	0.130	0.37
150	0.31	0.32	0.145	0.35	0.28	0.125	0.30
185	0.25	0.26	0.145	0.29	0.22	0.125	0.26
240	0.195	0.200	0.140	0.24	0.175	0.125	0.21
300	0.155	0.160	0.140	0.21	0.140	0.120	0.185
400	0.120	0.130	0.140	0.190	0.115	0.120	0.165

**TABLE 4E3A — Single-core 90°C armoured XLPE Insulated and PVC Sheathed cables, Aluminium wire armour (COPPER CONDUCTORS)**



**CURRENT-CARRYING CAPACITY (amperes):**

Ambient temperature: 30°C  
Conductor operating temperature: 90°C

Conductor cross-sectional area	Reference Method C (clipped direct)		Reference Method F (in free air or on a perforated cable tray horizontal or vertical)								
	Touching		Touching			Spaced by one cable diameter					
	2 cables, single-phase a.c. or d.c. flat	3 or 4 cables, three-phase a.c. flat	2 cables, single-phase a.c. or d.c. flat	3 cables, three-phase a.c. flat	3 cables, three-phase a.c. trefoil	2 cables, d.c.		2 cables, single-phase a.c.		3 or 4 cables, three-phase a.c.	
						Horizontal	Vertical	Horizontal	Vertical	Horizontal	Vertical
1	2	3	4	5	6	7	8	9	10	11	12
(mm <sup>2</sup> )	(A)	(A)	(A)	(A)	(A)	(A)	(A)	(A)	(A)	(A)	(A)
50	237	220	253	232	222	284	270	282	266	288	266
70	303	277	322	293	285	356	349	357	337	358	331
95	367	333	389	352	346	446	426	436	412	425	393
120	425	383	449	405	402	519	497	504	477	485	449
150	488	437	516	462	463	600	575	566	539	549	510
185	557	496	587	524	529	688	660	643	614	618	574
240	656	579	689	612	625	815	782	749	714	715	666
300	755	662	792	700	720	943	906	842	805	810	755
400	853	717	899	767	815	1137	1094	929	889	848	797
500	962	791	1016	851	918	1314	1266	1032	989	923	871
630	1082	861	1146	935	1027	1528	1474	1139	1092	992	940
800	1170	904	1246	987	1119	1809	1744	1204	1155	1042	978
1000	1261	961	1345	1055	1214	2100	2026	1289	1238	1110	1041

**Notes:**

1. Where a conductor operates at a temperature exceeding 70°C, it must be ascertained that the equipment connected to the conductor is suitable for the conductor operating temperature (see Regulation 512.1.2).
2. Where cables in this table are connected to equipment or accessories designed to operate at a temperature not exceeding 70°C, the current ratings given in the equivalent table for 70°C thermoplastic insulated cables (Table 4D3A) must be used (see also Regulation 523.1).

**TABLE 4E3B — Single-core 90°C armoured XLPE Insulated and PVC Sheathed cables, Aluminium wire armour (COPPER CONDUCTORS)**



**VOLTAGE DROP (per ampere per metre):**

Conductor operating temperature: 90°C

Conductor cross-sectional area 1	2 Cables d.c. 2	Reference Methods C & F (clipped direct, on tray or in free air)														
		2 cables, single-phase a.c.						3 or 4 cables, three-phase a.c.								
		Touching 3			Spaced* 4			Trefoil and touching 5			Flat and touching 6			Flat and spaced* 7		
[mm <sup>2</sup> ]	[mV/A/m]	[mV/A/m]			[mV/A/m]			[mV/A/m]			[mV/A/m]			[mV/A/m]		
		r	x	z	r	x	z	r	x	z	r	x	z	r	x	z
50	0.98	0.99	0.21	1.00	0.98	0.29	1.00	0.86	0.180	0.87	0.84	0.25	0.88	0.84	0.33	0.90
70	0.67	0.68	0.200	0.71	0.69	0.29	0.75	0.59	0.170	0.62	0.60	0.25	0.65	0.62	0.32	0.70
95	0.49	0.51	0.195	0.55	0.53	0.28	0.60	0.44	0.170	0.47	0.46	0.24	0.52	0.49	0.31	0.58
120	0.39	0.41	0.190	0.45	0.43	0.27	0.51	0.35	0.165	0.39	0.38	0.24	0.44	0.41	0.30	0.51
150	0.31	0.33	0.185	0.38	0.36	0.27	0.45	0.29	0.160	0.33	0.31	0.23	0.39	0.34	0.29	0.45
185	0.25	0.27	0.185	0.33	0.30	0.26	0.40	0.23	0.160	0.28	0.26	0.23	0.34	0.29	0.29	0.41
240	0.195	0.21	0.180	0.28	0.24	0.26	0.35	0.180	0.155	0.24	0.21	0.22	0.30	0.24	0.28	0.37
300	0.155	0.170	0.175	0.25	0.195	0.25	0.32	0.145	0.150	0.21	0.170	0.22	0.28	0.20	0.27	0.34
400	0.115	0.145	0.170	0.22	0.180	0.24	0.30	0.125	0.150	0.195	0.160	0.21	0.27	0.20	0.27	0.33
500	0.093	0.125	0.170	0.21	0.165	0.24	0.29	0.105	0.145	0.180	0.145	0.20	0.25	0.190	0.24	0.31
630	0.073	0.105	0.165	0.195	0.150	0.23	0.27	0.092	0.145	0.170	0.135	0.195	0.24	0.175	0.23	0.29
800	0.056	0.090	0.160	0.190	0.145	0.23	0.27	0.086	0.140	0.165	0.130	0.180	0.23	0.175	0.195	0.26
1000	0.045	0.092	0.155	0.180	0.140	0.21	0.25	0.080	0.135	0.155	0.125	0.170	0.21	0.165	0.180	0.24

Note: \* Spacings larger than one cable diameter will result in a larger voltage drop.

**TABLE 4E4A — Multi-core 90°C armoured XLPE Insulated and PVC Sheathed cables, (COPPER CONDUCTORS)**



Air Ambient temperature: 30°C  
 Ground ambient temperature: 20°C  
 Conductor operating temperature: 90°C

**CURRENT-CARRYING CAPACITY (amperes):**

Conductor cross-sectional area	Reference Method C (clipped direct)		Reference Method E (in free air or on a perforated cable tray etc. horizontal or vertical)		Reference Method D (direct in ground or in ducting in ground, in or around buildings)	
	1 two-core cable, single-phase a.c. or d.c.	1 three or 1 four-core cable, three-phase a.c.	1 two-core cable, single-phase a.c. or d.c.	1 three or 1 four-core cable, three-phase a.c.	1 two-core cable, single-phase a.c. or d.c.	1 three or 1 four-core cable, three-phase a.c.
1	2	3	4	5	6	7
(mm <sup>2</sup> )	[A]	[A]	[A]	[A]	[A]	[A]
1.5	27	23	29	25	25	21
2.5	36	31	39	33	33	28
4	49	42	52	44	43	36
6	62	53	66	56	53	44
10	85	73	90	78	71	58
16	110	94	115	99	91	75
25	146	124	152	131	116	96
35	180	154	188	162	139	115
50	219	187	228	197	164	135
70	279	238	291	251	203	167
95	338	289	354	304	239	197
120	392	335	410	353	271	223
150	451	386	472	406	306	251
185	515	441	539	463	343	281
240	607	520	636	546	395	324
300	698	599	732	628	446	365
400	787	673	847	728	-	-

**Notes:**

1. Where a conductor operates at a temperature exceeding 70°C it must be ascertained that the equipment connected to the conductor is suitable for the conductor operating temperature (see Regulation 512.1.2).
2. Where cables in this table are connected to equipment or accessories designed to operate at a temperature not exceeding 70°C, the current ratings given in the equivalent table for 70°C thermoplastic insulated cables (Table 4D4A) must be used (see also Regulation 523.1).

**TABLE 4E4B — Multi-core 90°C armoured XLPE Insulated and PVC Sheathed cables, (COPPER CONDUCTORS)**

**VOLTAGE DROP (per ampere per metre):**

Conductor operating temperature: 90°C

Conductor cross-sectional area 1	Two-core cable, d.c.	Two-core cable, single-phase a.c.			Three or four-core cable, three-phase a.c.		
	2	3			4		
[mm <sup>2</sup> ]	(mV/A/m)	(mV/A/m)			(mV/A/m)		
1.5	31	31			27		
2.5	19	19			16		
4	12	12			10		
6	7.9	7.9			6.8		
10	4.7	4.7			4.0		
16	2.9	2.9			2.5		
		r	X	Z	r	x	Z
25	1.85	1.85	0.160	1.90	1.60	0.140	1.65
35	1.35	1.35	0.155	1.35	1.15	0.135	1.15
50	0.98	0.99	0.155	1.00	0.86	0.135	0.87
70	0.67	0.67	0.150	0.69	0.59	0.130	0.60
95	0.49	0.50	0.150	0.52	0.43	0.130	0.45
120	0.39	0.40	0.145	0.42	0.34	0.130	0.37
150	0.31	0.32	0.145	0.35	0.28	0.125	0.30
185	0.25	0.26	0.145	0.29	0.22	0.125	0.26
240	0.195	0.20	0.140	0.24	0.175	0.125	0.21
300	0.155	0.16	0.140	0.21	0.140	0.120	0.185
400	0.120	0.13	0.140	0.190	0.115	0.120	0.165

**TABLE 4J1A — Single-core 90 °C XLPE Insulated cables, unarmoured, with or without PVC sheath (ALUMINIUM CONDUCTORS)**



Ambient temperature: 30°C  
Conductor operating temperature: 90°C

**CURRENT-CARRYING CAPACITY (amperes):**

Conductor cross-sectional area	Reference Method B (enclosed in conduit on a wall or in trunking etc.)		Reference Method C (clipped direct)		Reference Method F (in free air or on a perforated cable tray horizontal or vertical etc.) Touching			Reference Method G (in free air) Spaced By one cable diameter	
	2 cables, single-phase a.c. or d.c.	3 or 4 cables, three-phase a.c.	2 cables, single-phase a.c. or d.c. flat and touching	3 or 4 cables, three-phase a.c. flat and touching or trefoil	2 cables, single-phase a.c. or d.c. flat	3 cables, three-phase a.c. flat	3 cables, three-phase a.c. trefoil	2 Cables, single-phase a.c. or d.c. or 3 cables three-phase a.c. flat	
	2	3	4	5	6	7	8	Horizontal	Vertical
1	2	3	4	5	6	7	8	9	10
[mm <sup>2</sup> ]	[A]	[A]	[A]	[A]	[A]	[A]	[A]	[A]	[A]
50	157	140	154	136	184	165	159	210	188
70	200	179	198	174	237	215	206	271	244
95	242	217	241	211	289	264	253	332	300
120	281	251	280	245	337	308	296	387	351
150	307	267	324	283	389	358	343	448	408
185	351	300	371	323	447	413	395	515	470
240	412	351	439	382	530	492	471	611	561
300	471	402	508	440	613	571	544	708	652

**Notes:**

1. Where a conductor operates at a temperature exceeding 70°C it must be ascertained that the equipment connected to the conductor is suitable for the conductor operating temperature (see Regulation 512.1.2).
2. Where cables in this table are connected to equipment or accessories designed to operate at a temperature not exceeding 70°C, the current ratings given in the equivalent table for 70°C thermoplastic insulated cables [Table 4H1A] must be used (see also Regulation 523.1).

Table 34

TABLE 4J1B — Single-core 90 °C XLPE Insulated cables, unarmoured, with or without PVC sheath (ALUMINIUM CONDUCTORS)



VOLTAGE DROP (per ampere per metre):

Conductor operating temperature: 90°C

Conductor cross-sectional area 1	2 Cables d.c.	2 cables, single-phase a.c.									3 or 4 cables, three-phase a.c.											
		Reference Method B (enclosed in conduit or trunking)			Reference Methods C, F & G (clipped direct, on tray or in free air)						Reference Method B (enclosed in conduit or trunking)	Reference Methods C, F & G (clipped direct, on tray or in free air)										
					Cables touching			Cables spaced*				Cables touching, Trefoil			Cables touching, Flat			Cables spaced*, Flat				
(mm <sup>2</sup> )	(mV/A/m)	(mV/A/m)			(mV/A/m)			(mV/A/m)			(mV/A/m)			(mV/A/m)			(mV/A/m)					
		r	x	z	r	x	z	r	x	z	r	x	z	r	x	z	r	x	z	r	x	z
50	1.65	1.70	0.30	1.72	1.65	0.190	1.66	1.65	0.28	1.68	1.44	0.26	1.46	1.44	0.165	1.45	1.44	0.24	1.46	1.44	0.32	1.48
70	1.13	1.17	0.30	1.21	1.12	0.185	1.14	1.12	0.27	1.15	1.00	0.26	1.04	0.97	0.160	0.98	0.97	0.24	1.00	0.97	0.31	1.02
95	0.82	0.86	0.29	0.91	0.82	0.185	0.84	0.82	0.27	0.94	0.75	0.25	0.79	0.71	0.160	0.73	0.71	0.23	0.75	0.71	0.31	0.78
120	0.65	0.68	0.29	0.74	0.65	0.180	0.67	0.65	0.27	0.70	0.59	0.25	0.64	0.57	0.155	0.59	0.57	0.23	0.61	0.57	0.31	0.64
150	0.53	0.54	0.28	0.61	0.52	1.75	0.55	0.52	0.26	0.58	0.48	0.24	0.54	0.45	0.155	0.47	0.45	0.23	0.50	0.45	0.30	0.54
185	0.42	0.45	0.28	0.53	0.43	0.175	0.46	0.42	0.26	0.49	0.38	0.24	0.45	0.36	0.150	0.39	0.36	0.23	0.43	0.36	0.30	0.47
240	0.32	0.34	0.27	0.43	0.32	0.170	0.36	0.32	0.26	0.41	0.30	0.24	0.38	0.28	0.150	0.32	0.28	0.22	0.35	0.28	0.30	0.41
300	0.26	0.28	0.27	0.38	0.26	0.170	0.31	0.26	0.26	0.36	0.25	0.23	0.34	0.22	0.145	0.27	0.22	0.22	0.31	0.22	0.30	0.37

Note: \* Spacings larger than one cable diameter will result in a larger voltage drop.

**TABLE 4J2A — Multi-core 90 °C XLPE Insulated and PVC Sheathed cables, non-armoured (ALUMINIUM CONDUCTORS)**



Ambient temperature: 30°C  
Conductor operating temperature: 90°C

**CURRENT-CARRYING CAPACITY (amperes):**

Conductor cross-sectional area	Reference Method B (enclosed in conduit on a wall or in trunking etc.)		Reference Method C (clipped direct)		Reference Method E (in free air or on a perforated Cable tray etc, Horizontal or vertical)	
	1 two-core Cable, single-Phase a.c. or d.c.	1 three- or Four-core Cable, three-Phase a.c.	1 two-core Cable, single-Phase a.c. or d.c.	1 three- or Four-core Cable, three-Phase a.c.	1 two-core Cable, single-Phase a.c. or d.c.	1 three- or Four-core Cable, three-Phase a.c.
1	2	3	4	5	6	7
(mm <sup>2</sup> )	(A)	(A)	(A)	(A)	(A)	(A)
16	72	64	84	76	91	77
25	94	84	101	90	108	97
35	115	103	126	112	135	120
50	138	124	154	136	164	146
70	175	156	198	174	211	187
95	210	188	241	211	257	227
120	-	216	-	245	-	263
150	-	240	-	283	-	304
185	-	272	-	323	-	347
240	-	318	-	382	-	409
300	-	364	-	440	-	471

**Notes:**

1. Where a conductor operates at a temperature exceeding 70°C, it must be ascertained that the equipment connected to the conductor is suitable for the conductor operating temperature [see Regulation 512.1.2].
2. Where cables in this table are connected to equipment or accessories designed to operate at a temperature not exceeding 70°C, the current ratings given in the equivalent table for 70°C thermoplastic insulated cables (Table 4H2A) must be used (see also Regulation 523.1).

**TABLE 4J2B — Multi-core 90 °C XLPE Insulated and PVC Sheathed cables, non-armoured (ALUMINIUM CONDUCTORS)**



**VOLTAGE DROP (per ampere per metre):**

Conductor operating temperature: 90°C

Conductor cross-sectional area 1	Two-core cable, d.c.	Two-core cable, single-phase a.c.			Three or four-core cable, three-phase a.c.		
	2	3			4		
[mm <sup>2</sup> ]	(mV/A/m)	(mV/A/m)			(mV/A/m)		
16	4.8	4.8			4.2		
		r	x	z	r	x	z
25	3.1	3.1	0.165	3.1	2.7	0.140	2.7
35	2.2	2.2	0.160	2.2	1.90	0.140	1.95
50	1.60	1.60	0.160	1.65	1.40	0.135	1.45
70	1.10	1.10	0.155	1.15	0.96	0.135	0.97
95	0.82	0.82	0.150	0.84	0.71	0.130	0.72
120	-	-	-	-	0.56	0.130	0.58
150	-	-	-	-	0.45	0.130	0.47
185	-	-	-	-	0.37	0.130	0.39
240	-	-	-	-	0.28	0.125	0.31
300	-	-	-	-	0.23	0.125	0.26

**TABLE 4J3A — Single-core 90°C armoured XLPE Insulated and PVC Sheathed cables  
Aluminium wire armour (ALUMINIUM CONDUCTORS)**



Ambient temperature: 30°C  
Conductor operating temperature: 90°C

**CURRENT-CARRYING CAPACITY (amperes):**

Conductor cross-sectional area	Reference Method C (clipped direct)		Reference Method F (in free air or on a perforated cable tray, horizontal or vertical)								
	Touching		Touching			Spaced by one cable diameter					
	2 cables, single-phase a.c. or d.c. flat	3 or 4 cables, three-phase a.c. flat	2 cables, single-phase a.c. or d.c. flat	3 cables, three-phase a.c. flat	3 cables, three-phase a.c. trefoil	2 cables, d.c.		2 cables, single-phase a.c.		3 or 4 cables, three-phase a.c.	
						Horizontal	Vertical	Horizontal	Vertical	Horizontal	Vertical
1	2	3	4	5	6	7	8	9	10	11	12
(mm <sup>2</sup> )	(A)	(A)	(A)	(A)	(A)	(A)	(A)	(A)	(A)	(A)	(A)
50	179	165	192	176	162	216	197	212	199	215	192
70	228	209	244	222	207	275	253	269	254	270	244
95	276	252	294	276	252	332	307	328	310	324	296
120	320	291	340	308	292	384	357	378	358	372	343
150	368	333	390	352	337	441	411	429	409	424	394
185	419	378	444	400	391	511	480	490	467	477	447
240	494	443	521	468	465	605	572	576	549	554	523
300	568	508	597	536	540	701	666	654	624	626	595

**Notes:**

1. Where a conductor operates at a temperature exceeding 70°C, it must be ascertained that the equipment connected to the conductor is suitable for the conductor operating temperature [see Regulation 512.1.2].
2. Where cables in this table are connected to equipment or accessories designed to operate at a temperature not exceeding 70°C, the current ratings given in the equivalent table for 70°C thermoplastic insulated cables (Table 4H3A) must be used [see also Regulation 523.1].

**TABLE 4J3B — Single-core 90°C armoured XLPE Insulated and PVC Sheathed cables  
Aluminium wire armour (ALUMINIUM CONDUCTORS)**



**VOLTAGE DROP (per ampere per metre):**

Conductor operating temperature: 90°C

Conductor cross-sectional area 1	2 Cables d.c. 2	Reference Methods C & F (clipped direct, on tray or in free air)														
		2 cables, single-phase a.c.						3 or 4 cables, three-phase a.c.								
		Touching 3			Spaced* 4			Trefoil and touching 5			Flat and touching 6			Flat and spaced* 7		
[mm <sup>2</sup> ]	[mV/A/m]	[mV/A/m]			[mV/A/m]			[mV/A/m]			[mV/A/m]			[mV/A/m]		
		r	x	z	r	x	z	r	x	z	r	x	z	r	x	z
50	1.60	1.60	0.22	1.60	1.60	0.30	1.60	1.40	0.185	1.40	1.40	0.26	1.40	1.35	0.34	1.40
70	1.10	1.10	0.21	1.15	1.10	0.29	1.15	0.96	0.180	0.98	0.97	0.25	1.00	0.99	0.33	1.05
95	0.82	0.83	0.20	0.85	0.85	0.29	0.90	0.71	0.175	0.74	0.74	0.25	0.78	0.76	0.32	0.83
120	0.66	0.66	0.20	0.69	0.69	0.28	0.74	0.57	0.170	0.60	0.60	0.24	0.64	0.63	0.31	0.70
150	0.52	0.53	0.195	0.57	0.56	0.28	0.62	0.46	0.170	0.49	0.49	0.24	0.54	0.52	0.30	0.60
185	0.42	0.43	0.190	0.47	0.46	0.27	0.54	0.38	0.165	0.41	0.40	0.24	0.47	0.44	0.30	0.53
240	0.32	0.34	0.185	0.39	0.37	0.27	0.45	0.29	0.160	0.34	0.32	0.23	0.39	0.35	0.29	0.46
300	0.26	0.27	0.185	0.33	0.30	0.26	0.40	0.24	0.160	0.29	0.26	0.23	0.34	0.29	0.29	0.41

Note: \* Spacings larger than one cable diameter will result in a larger voltage drop.

**TABLE 4J4A — Multi-core 90°C armoured XLPE Insulated and PVC Sheathed cables (ALUMINIUM CONDUCTORS)**



Air Ambient temperature: 30°C  
 Ground ambient temperature: 20°C  
 Conductor operating temperature: 90°C

**CURRENT-CARRYING CAPACITY (amperes):**

Conductor cross-sectional area	Reference Method C (clipped direct)		Reference Method E (in free air or on a perforated cable tray etc. horizontal or vertical)		Reference Method D (direct in ground or in ducting in ground, in or around buildings)	
	1 two-core cable, single-phase a.c. or d.c.	1 three or 1 four-core cable, three-phase a.c.	1 two-core cable, single-phase a.c. or d.c.	1 three or 1 four-core cable, three-phase a.c.	1 two-core cable, single-phase a.c. or d.c.	1 three or 1 four-core cable, three-phase a.c.
1	2	3	4	5	6	7
(mm <sup>2</sup> )	(A)	(A)	(A)	(A)	(A)	(A)
16	82	71	85	74	71	59
25	108	92	112	98	90	75
35	132	113	138	120	108	90
50	159	137	166	145	128	106
70	201	174	211	185	158	130
95	242	214	254	224	186	154
120	-	249	-	264	-	174
150	-	284	-	305	-	197
185	-	328	-	350	-	220
240	-	386	-	418	-	253
300	-	441	-	488	-	286

**Notes:**

1. Where a conductor operates at a temperature exceeding 70°C, it must be ascertained that the equipment connected to the conductor is suitable for the conductor operating temperature (see Regulation 512.1.2).
2. Where cables in this table are connected to equipment or accessories designed to operate at a temperature not exceeding 70°C, the current ratings given in the equivalent table for 70°C thermoplastic insulated cables (Table 4H4A) must be used (see also Regulation 523.1).

**TABLE 4J4B — Multi-core 90°C armoured XLPE Insulated and PVC Sheathed cables (ALUMINIUM CONDUCTORS)**



**VOLTAGE DROP (per ampere per metre):**

Conductor operating temperature: 90°C

Conductor cross-sectional area 1	Two-core cable, d.c.	Two-core cable, Single-phase a.c.			Three- or four-core cable, three-phase a.c.		
	2	3			4		
[mm <sup>2</sup> ]	(mV/A/m)	(mV/A/m)			(mV/A/m)		
16	4.8	4.8			4.2		
		r	x	z	r	x	z
25	3.1	3.1	0.165	3.1	2.7	0.140	2.7
35	2.2	2.2	0.160	2.2	1.90	0.140	1.95
50	1.60	1.65	0.160	1.65	1.40	0.135	1.45
70	1.10	1.10	0.155	1.15	0.96	0.135	0.97
95	0.82	0.82	0.150	0.84	0.71	0.130	0.72
120	-	-	-	-	0.56	0.130	0.58
150	-	-	-	-	0.45	0.130	0.47
185	-	-	-	-	0.37	0.130	0.39
240	-	-	-	-	0.28	0.125	0.31
300	-	-	-	-	0.23	0.125	0.26

## Correction Factors:

Table 41

**TABLE 4B1 — Rating factors for ambient air temperatures other than 30°C to be applied to the current-carrying capacities for cables in free air.**

Ambient temperature °C	Insulation	
	70 °C PVC	90 °C XLPE
25	1.03	1.02
30	1.00	1.00
35	0.94	0.96
40	0.87	0.91
45	0.79	0.87
50	0.71	0.82
55	0.61	0.76

Table 42

**TABLE 4B2 - Rating factors for ambient ground temperatures other than 20°C to be applied to the current-carrying capacities for cables buried direct in the ground or in an underground conduit system to BS EN 50086-2-4.**

Ground temperature °C	Insulation	
	70 °C PVC	90 °C XLPE
10	1.10	1.07
15	1.05	1.04
20	1.00	1.00
25	0.95	0.96
30	0.89	0.93
35	0.84	0.89
40	0.77	0.85
45	0.71	0.80

Table 43

**TABLE 4B3 – Rating factors for cables buried direct in the ground or in an underground conduit system to BS EN 50086-2-4 for soil thermal resistivities other than 2.5 K.m/W to be applied to the current-carrying capacities for Reference Method D**

Thermal resistivity, K.m/W	0.5	0.8	1	1.5	2	2.5	3
Rating factor for cables in buried ducts	1.28	1.20	1.18	1.1	1.05	1	0.96
Rating factor for direct buried cables	1.88	1.62	1.5	1.28	1.12	1	0.90

Note 1: The rating factors given have been averaged over the range of conductor sizes and types of installation included in the relevant tables in this appendix. The overall accuracy of rating factors is within  $\pm 5\%$ .

Note 2: The rating factors are applicable to cables drawn into buried ducts. For cables laid direct in the ground the rating factors for thermal resistivities less than 2.5 K.m/W will be higher. Where more precise values are required they may be calculated by methods given in BS 7769 (BS IEC 60287).

Note 3: The rating factors are applicable to ducts buried at depths of up to 0.8m

Table 44

**Table 4C1 — Rating factors for one circuit or one multicore cable or for a group of circuits, or a group of multicore cables**

Arrangement (cables touching)	Number of circuits or multicore cables												To be used with current-carrying capacities, Reference
	1	2	3	4	5	6	7	8	9	12	16	20	
Bunched in air, on a surface, embedded or enclosed	1.00	0.80	0.70	0.65	0.60	0.57	0.54	0.52	0.50	0.45	0.41	0.38	Methods A to F
Single layer on wall or floor	1.00	0.85	0.79	0.75	0.73	0.72	0.72	0.71	0.70	0.70	0.70	0.70	Method C
Single layer multicore on a perforated horizontal or vertical cable tray system	1.00	0.88	0.82	0.77	0.75	0.73	0.73	0.72	0.72	0.72	0.72	0.72	Methods E and F
Single layer multicore on cable ladder system or cleats etc.	1.00	0.87	0.82	0.80	0.80	0.79	0.79	0.78	0.78	0.78	0.78	0.78	

Note 1: These factors are applicable to uniform groups of cables, equally loaded.

Note 2: Where horizontal clearances between adjacent cables exceed twice their overall diameter, no rating factor needs to be applied.

Note 3: The same factors are applied to:

- Groups of two or three single-core cables;
- Multicore cables

Note 4: If a system consists of both two and three-core cables, the total number of cables is taken as the number of circuits and the corresponding factor is applied to the tables for two loaded conductors for the two-core cables and to the tables for three loaded conductors for the three-core cables.

Note 5: If a group consists of  $n$  single-core cables, it may either be considered as  $n/2$  circuits of two loaded conductors or  $n/3$  circuits of three loaded conductors.

Note 6: The rating factors given have been averaged over the range of conductor sizes and types of the overall accuracy of tabulated values is within 5%.

Note 7: For some installations and for other methods not provided for in the above table, it may be appropriate to use factors calculated for specific cases, see Tables 4C4 and 4C5, for example.

Note 8: When cables having differing conductor operating temperature are grouped together, the current rating is to be based upon the lowest operating temperature of any cable in the group.

Note 9: If due to known operating conditions, a cable is expected to carry not more than 30% of its grouped rating, it may be ignored for the purpose of obtaining the rating factor for the rest of the group.

For example, a group of  $N$  loaded cables would normally require a group rating factor of  $C_g$  applied to the tabulated  $I_t$ .

However, if  $M$  cables in the group carry loads which are not greater than  $0.3 C_g I_t$  amperes the other cables can be sized by using the group rating factor corresponding to  $(N-M)$  cables.

**Table 4C2 — Rating factors for more than one circuit, cables laid directly in the ground — Reference Method D Single-core or Multi - core cables**

Cable-to-cable clearance ( $\alpha$ )					
Number of circuits	Nil (cables touching)	One cable diameter	0.125 m	0.25 m	0.5 m
2	0.75	0.80	0.85	0.90	0.90
3	0.65	0.70	0.75	0.80	0.85
4	0.60	0.60	0.70	0.75	0.80
5	0.55	0.55	0.65	0.70	0.80
6	0.50	0.55	0.60	0.70	0.80

Multicore cables



Single-core cables



Note 1: Values given apply to an installation depth of 0.7m and a soil thermal resistivity of 2.5 K.m/W. These are average values. The process of averaging, together with rounding off, can result in some cases in errors of up to  $\pm 10\%$ . [Where more precise values are required they may be calculated by methods given in BS 7769 (BS IEC 60287).]

Note 2: In case of a thermal resistivity lower than 2.5 K.m/W, the rating factors can, in general, be increased and can be calculated by the methods given in BS 7769 (BS IEC 60287).

Table 46

TABLE 4C3 — Rating factors for more than one circuit, cables laid in ducts in the ground — Reference Method D

i) Multi-core cables in single-way ducts

Duct-to-duct clearance ( $\alpha$ )				
Number of cables	Nil (ducts touching)	0.25 m	0.5 m	1.0 m
2	0.85	0.90	0.95	0.95
3	0.75	0.85	0.90	0.95
4	0.70	0.80	0.85	0.90
5	0.65	0.80	0.85	0.90
6	0.60	0.80	0.80	0.90

Multicore cables

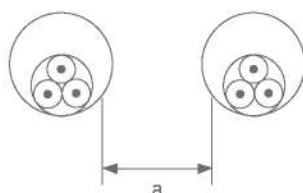

Note 1: Values given apply to an installation depth of 0.7m and a soil thermal resistivity of 2.5 K.m/W. They are average values. The process of averaging, together with rounding off, can result in some cases in errors of up to  $\pm 10\%$ . (Where more precise values are required they may be calculated by methods given in BS 7769 [BS IEC 60287])

Note 2: In case of a thermal resistivity lower than 2.5 K.m/W, the rating factors can, in general, be increased and can be calculated by the methods given in BS 7769 [BS IEC 60287].

ii) Single-core cables in non-ferrous single-way ducts

Table 47

Duct-to-duct clearance ( $\alpha$ )				
Number of single-core circuits of two or three cables	Nil (ducts touching)	0.25 m	0.5 m	1.0 m
2	0.80	0.90	0.90	0.95
3	0.70	0.80	0.85	0.90
4	0.65	0.75	0.80	0.90
5	0.60	0.70	0.80	0.90
6	0.60	0.70	0.80	0.90

Single-core cables



Note 1: Values given apply to an installation depth of 0.7m and a soil thermal resistivity of 2.5 K.m/W. They are average values. The process of averaging, together with rounding off, can result in some cases in errors of up to  $\pm 10\%$ . (Where more precise values are required they may be calculated by methods given in BS 7769 [BS IEC 60287]).

Note 2: In case of a thermal resistivity lower than 2.5 K.m/W, the rating factors can, in general, be increased and can be calculated by the methods given in BS 7769 [BS IEC 60287].

**TABLE 4C4 — Rating factors for groups of more than one multicore cable, to be applied to reference current-carrying capacities for multicore cables in free air — Reference Method E**

Installation Method in Table 4A2		Number of trays or ladders	Number of cables per tray or ladder						
			1	2	3	4	6	9	
Perforated cable tray systems (Note 3)	31	<p>Touching</p>	1	See item 4 of Table 4C1					
			2	1.00	0.87	0.80	0.77	0.73	0.68
			3	1.00	0.86	0.79	0.76	0.71	0.66
			6	1.00	0.84	0.77	0.73	0.68	0.64
		<p>Spaced</p>	1	1.00	1.00	0.98	0.95	0.91	-
			2	1.00	0.99	0.96	0.92	0.87	-
3	1.00		0.98	0.95	0.91	0.85	-		
Vertical perforated cable tray systems (Note 4)	31	<p>Touching</p>	1	See item 4 of Table 4C1					
			2	1.00	0.88	0.81	0.76	0.71	0.70
		<p>Spaced</p>	1	1.00	0.91	0.89	0.88	0.87	-
			2	1.00	0.91	0.88	0.87	0.85	-
			1	1.00	0.91	0.89	0.88	0.87	-
			2	1.00	0.91	0.88	0.87	0.85	-
Unperforated cable tray systems	30	<p>Touching</p>	1	0.97	0.84	0.78	0.75	0.71	0.68
			2	0.97	0.83	0.76	0.72	0.68	0.63
			3	0.97	0.82	0.75	0.71	0.66	0.61
			6	0.97	0.81	0.73	0.69	0.63	0.58
Cable ladder systems, cleats, wire mesh tray, etc. (Note 3)	32	<p>Touching</p>	1	See item 4 of Table 4C1					
			2	1.00	0.86	0.80	0.78	0.76	0.73
			3	1.00	0.85	0.79	0.76	0.73	0.70
			6	1.00	0.84	0.77	0.73	0.68	0.64
	33	<p>Spaced</p>	1	1.00	1.00	1.00	1.00	1.00	-
			2	1.00	0.99	0.98	0.97	0.96	-
34	<p>Spaced</p>	3	1.00	0.98	0.97	0.96	0.93	-	

Note 1: Values given are averages for the cable types and range of conductor sizes. The spread of values is generally less than 5%.

Note 2: Factors apply to single layer groups of cables as shown above and do not apply when cables are installed in more than one layer touching each other. Values for such installations may be significantly lower and must be determined by an appropriate method.

Note 3: Values are given for vertical spacing between cable trays of 300 mm and at least 20 mm between cable trays and wall. For closer spacing the factors should be reduced.

Note 4: Values are given for horizontal spacing between cable trays of 225 mm with cable trays mounted back to back. For closer spacing the factors should be reduced.

Table 49

**TABLE 4C5 — Rating factors for groups of one or more circuits of single-core cables to be applied to reference current-carrying capacity for one circuit of single-core in free air Reference Method F**

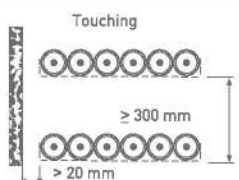
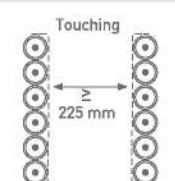
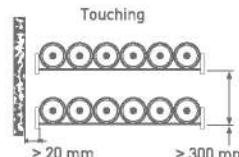
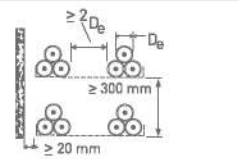
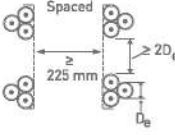
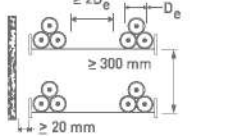
Installation Method in Table 4A2		Number of trays or ladders	Number of three-phase circuits per tray or ladder			Use as a multiplier or rating for		
			1	2	3			
Perforated cable tray systems [Note 3]	31			1	0.98	0.91	0.87	Three cables in horizontal formation
		2	0.96	0.87	0.81			
		3	0.95	0.85	0.78			
Vertical perforated cable tray systems [Note 4]	31			1	0.96	0.86	-	Three cables in vertical formation
		2	0.95	0.84	-			
Cable ladder systems, cleats, wire mesh tray, etc. [Note 3]	32			1	1.00	0.97	0.96	Three cables in horizontal formation
	33	2	0.98	0.93	0.89			
	34	3	0.97	0.90	0.86			
Perforated cable tray systems [Note 3]	31			1	1.00	0.98	0.96	Three cables in trefoil formation
		2	0.97	0.93	0.89			
		3	0.96	0.92	0.86			
Vertical perforated cable tray systems [Note 4]	31			1	1.00	0.91	0.89	
		2	1.00	0.90	0.86			
Cable ladder systems, cleats, wire mesh tray, etc. [Note 3]	32			1	1.00	1.00	1.00	
	33	2	0.97	0.95	0.93			
	34	3	0.96	0.94	0.90			

Note 1: Values given are averages for the cable types and range of conductor sizes. The spread of values is generally less than 5%.

Note 2: Factors apply to single layer groups of cables (or trefoil groups) as shown above and do not apply when cables are installed in more than one layer touching each other. Values for such installations may be significantly lower and must be determined by an appropriate method.

Note 3: Values are given for vertical spacing between cable trays of 300 mm and at least 20 mm between cable trays and wall. For closer spacing the factors should be reduced.

Note 4: Values are given for horizontal spacing between cable trays of 225 mm with cable trays mounted back to back. For closer spacing the factors should be reduced.

Note 5: For circuits having more than one cable in parallel per phase, each three-phase set of conductors is to be considered as a circuit for the purpose of this table.



# Short Circuit Ratings

## PVC insulated Cables

The values of fault current given in the graph are based on the cable being fully loaded at the start of the short circuit (conductor temperature 70°C) and a final conductor temperature of 160°C for conductor sizes up to and including 300mm<sup>2</sup> and 140°C for conductor sizes above 300mm<sup>2</sup>.

### Copper Conductors

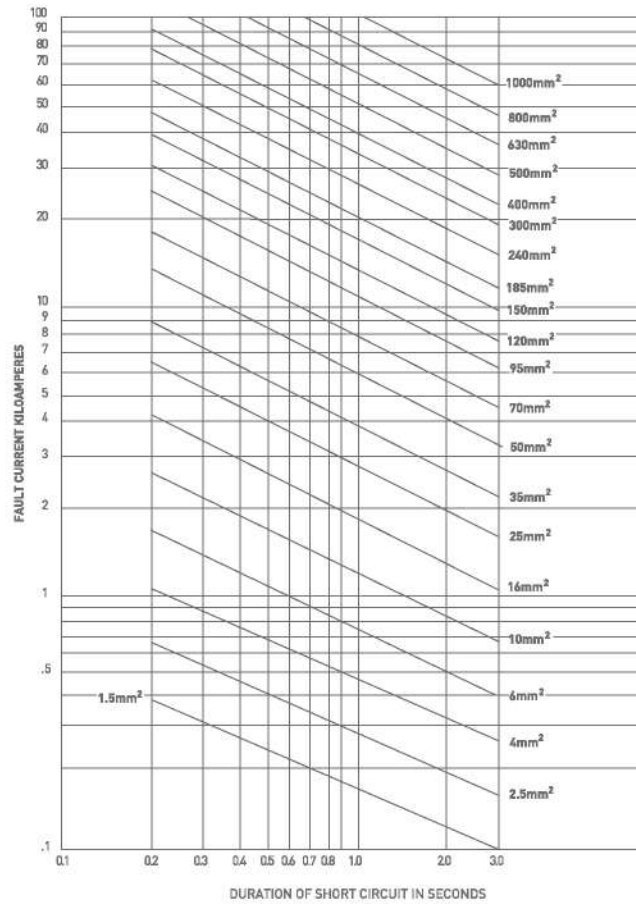

### Aluminium Conductors

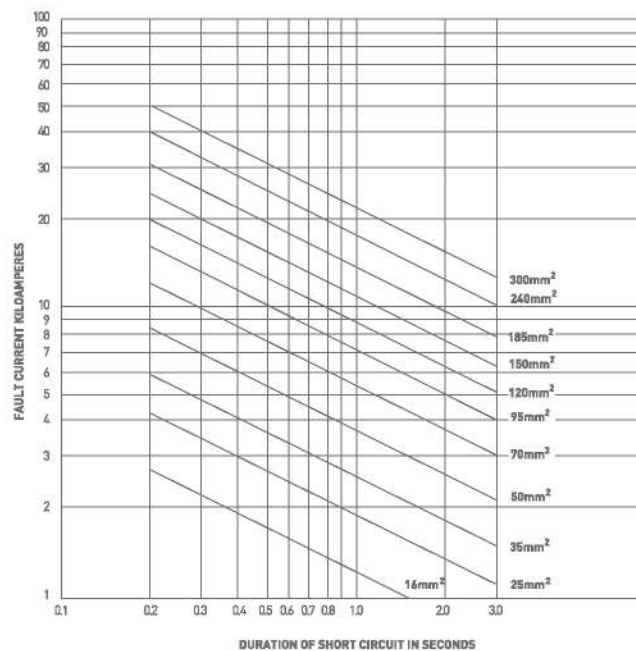

# Short Circuit Ratings

## XLPE Insulated Cables

The values of fault current given in the graph are based on the cable being fully loaded at the start of the short circuit (conductor temperature 90°C) and a final conductor temperature of 250°C. It should be ensured that the accessories associated with the cable are also capable of operation at these values of fault current and temperature.

### Copper Conductors

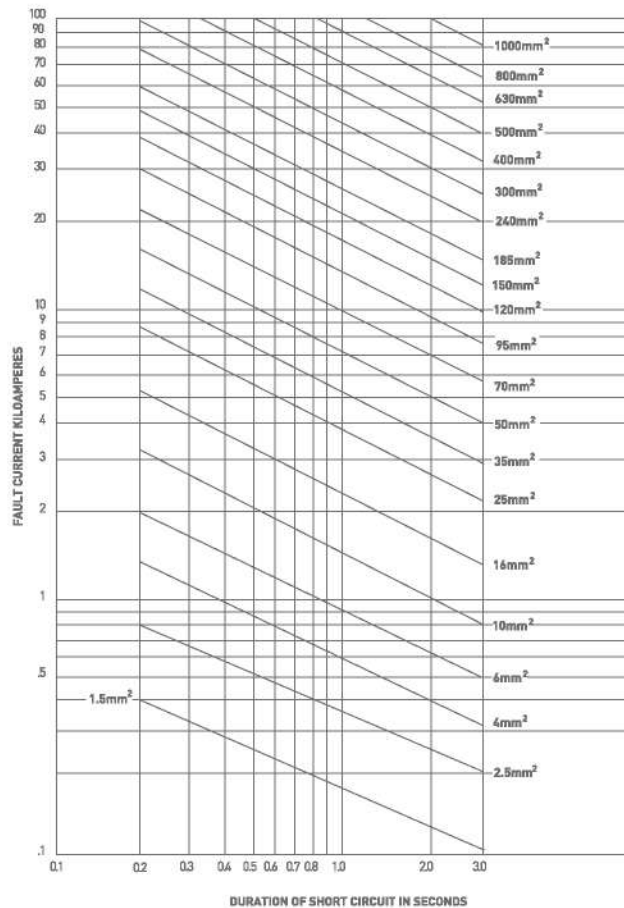

### Aluminium Conductors

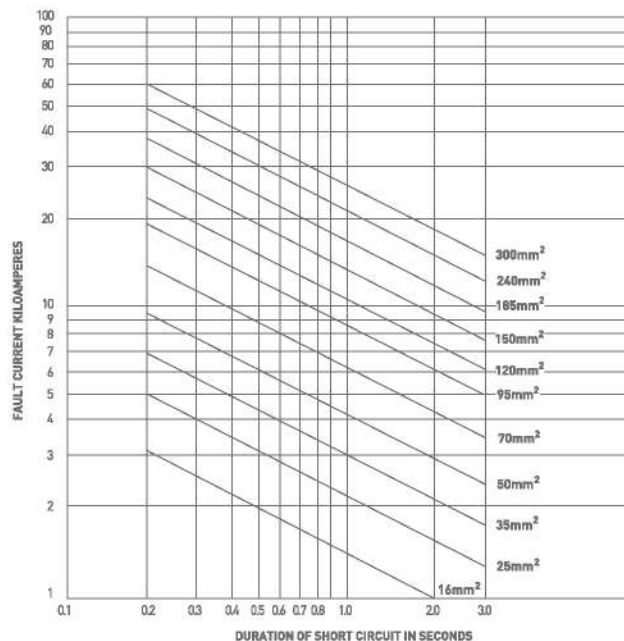



## Handling and Storage

### Environment

All the cables described in this publication can be used indoors or outdoors, but some reservations are necessary concerning following cables:

- (i) Unarmoured cables are not recommended for laying direct in the ground.
- (ii) For installations where there is water-logging or where it is likely to occur, advice should be obtained from our technical department. It may be desirable to recommend an alternative type of cable.

### Temperature

To avoid risk of damage during handling, cables should only be installed when both, they and the ambient temperatures, are above 5°C and have been so kept for 24 hours, or when special precautions have been taken to maintain the cable above this temperature. It is preferable that the cable is at a higher temperature.

### Sheath damage

Care should be taken to ensure that the oversheath is not damaged during installation. This is especially important where aluminium armour is used since ingress of moisture could lead to corrosion and ultimate loss of earth continuity.

### Minimum bending radius

Cables should not bend during installation to a radius smaller than that recommended below.

Wherever possible larger radii should be used.

[D=Overall diameter of cable.]

Type of Cable	Overall Diameter D	Minimum Bending Radius During installation
Circular Copper Conductor (Non-Armoured)		6D
Circular Copper Conductor (Armoured)		6D
Shaped Copper conductors (Armoured or Non-Armoured)		8D

### Handling:

Damage to cable can occur due to incorrect handling to which the drums and cables may be subjected, causing breakdown of the drum flanges and in exceptional cases, movement of the drum barrel. Once this breakdown of the drum occurs the cable is immediately exposed to damage.

Fork-lift trucks may be used in handling provided that care is exercised not to damage or remove the protective lagging when pushing the 'fork' under the drum flanges. Unloading can also be safely accomplished by means of ramps and winches. (See Fig. 1 & 2.)

Under no circumstances should a drum be rolled off a vehicle on to a 'cushion' of sand, tarpaulin, etc. This action could crumple the flanges and barrel of the drum, driving splinters and or nails into the cable. (See Fig.3)

### Rolling Drums:

Drums of cable must always be rolled in the direction shown by the arrow painted on the flanges, but such rolling should in any case be kept to a minimum.

### Turning Drums:

The best way to turn a cable drum is to roll it on to two well-greased thin plates or boards about 2 feet square. The plates can then be used as a turntable and the drum rotated to the desired direction.

### Lowering of Lifting Drums:

When drums are moved from one level to another, e.g. truck to ground, wharf to ship, etc., lifting and lowering gear must always be used. When drums are lifted from the upper layer of a tiered stack, care must be taken to ensure that no movement of the bottom layer occurs so as to cause collapse. Drums, whether loaded or empty, are too heavy to be manhandled, should always be slung; they should never be dropped. (See fig & 2).

## 1. Storage

If at any time the drums of cable are required to be stored for reasonably long periods, e.g. prior to shipment or installation, the following points should be noted.

- 1.1 The site for storage of drums should be well drained. Hard packed soil, or preferably a concrete surface, which will not allow the drums to sink and so give rise to damage due to the extreme difficulty in moving drums when they are sunk into the ground.
- 1.2 All drums should be stored with the lagging intact and in such a manner as to leave sufficient space between them for air circulation. Check and tighten barrel bolts on the drums at regular intervals.
- 1.3 Tier stacking of drums is not recommended. In no circumstances must the drums be stored on the flat i.e. with flanges horizontal. [Fig.4]  
When lifting drums of cable for loading or unloading, spindles must always be used in conjunction with crane slings, chain or lifting beams. On no account should any drum be lifted by wire slings. [Fig. 1]  
When lifting drums of cable, lifting beams or stretchers between the sling of chain pairs must be used to prevent flanges crushing on to the cable. [See Fig. 1]

**NOTE:** Normally the hooks or slings should be closed to the drum flanges.

- 1.4 All drums during installation [i.e. when the lagging has been removed] should be stored with the rims of flange touching, so that there is no danger of the flanges of drums coming into accidental contact with unprotected cable on other drums.

**IMPORTANT:** Cable ends must be sealed with end cap during storage and transportation.

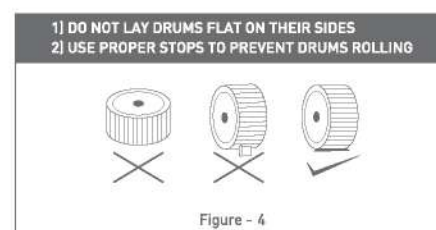
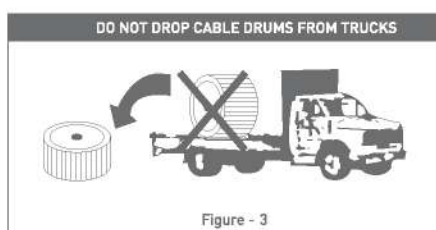
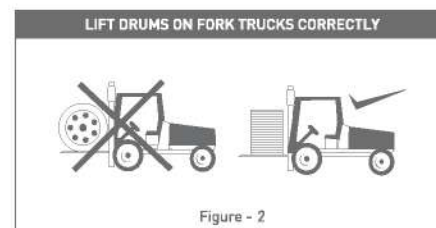
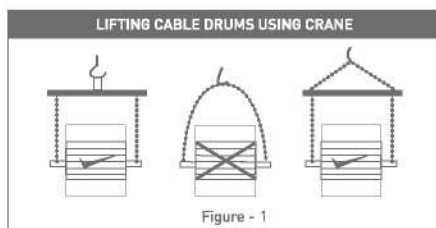

## Laying of Cables

The cable should preferably be drawn to its position in a continuous manner during steps. The cable will settle between rollers and may cause high strain on men and machines during restarting whether the pulling is manual or with a winch. It is necessary for one man to be stationed at the drum with a plank of wood wedged against the flange of the drum so that over running of the drum is prevented if the pulling stops. Otherwise, many loose turns can easily develop on the drum.

When pulling by a winch it is advantageous for the cable end to be taken by hand as far as possible before attaching the winch rope. This allows the leading cable rollers, skid plates, etc to take the load and settle under well-controlled conditions. The winch operator must at all times, carefully observe the dynamometer to prevent overloading. On long pulls, good communication is essential, preferably by radio.

When pulling a power winch, more attention has to be given to the maximum pulling load which is permissible. For such installations a pulling eye attached to the conductors is necessary and for copper conductors a pulling tension of 6 kg force per sq. mm of total conductor area can be applied [with the provision of 2000 kg force maximum].

Graphite paste should be used for lubrication when cables are being pulled into ducts or pipes.

For open trench and Straight installation, a cable stocking can be used. It is advisable, however, to protect the PVC oversheath with a layer of bitumen tape applied with 50% overlap.

Cables should never be bent to a small radius. As large a radius as space permits should be adopted. Under no circumstances should the bending radius be less than the minimum permissible limits. It is particularly important to have a generous bending radius when cables are to be pulled by a power winch, so as to keep within the maximum permissible pulling tension and prevent the cable being flattened around bends or in ducts.

**DO NOT PULL CABLE  
ACROSS LONG  
UNSUPPORTING SPANS**

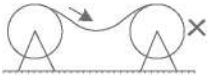

**DO NOT DRAG CABLE  
AGAINST SHARP EDGES**

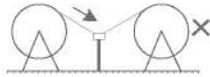

**PROVIDE FREELY  
ROTATING SUPPORTS**

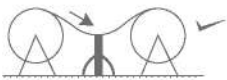

**DO NOT PULL CABLES  
WITH POWER VEHICLES**

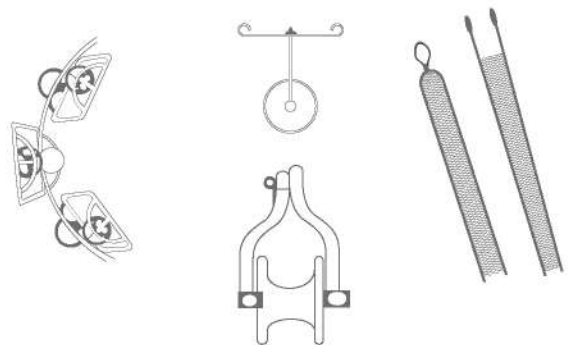
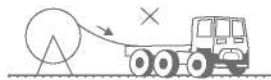

## Final Placing of Cable

Before disconnecting the pulling rope, the cable is laid off, i.e. starting at one end. It is carefully lifted from the rollers and deposited on the bottom of the trench. About 10m of cable should be lifted at one time, any slack being carried forward. The end position of a cable run may require double handling because it is not possible to draw cables straight into buildings. In this case the cable is overpulled, then man-handled into the required position. At all times the loops should be kept as large as possible so that the bending radius is always above the minimum permitted. Similarly at the drum locations the necessary length of cable may be unwound from the drum and laid out in a figure of '8' if space is limited, prior to cutting to length and placing into position. Immediately after cutting the cable ends must be suitably sealed, prevent ingress of moisture. In this respect it is also important to carefully examine the pulling end seal to ensure that it has not been damaged during laying. (see figures 14 & 15)

### Backfilling and Reinstatement.

Prior to backfilling, it is necessary to carry out a visual inspection, and items which need to be checked are:

- 1) The cables have a suitable bedding, such as sieved sand or soil. Stone chips and other sharp objects in the cable route should be removed.
- 2) The spacing is correct if there is more than one cable in the trench.
- 3) Pulling equipment is carefully removed.
- 4) The cable is free from obvious damage caused during installation. A very high proportion of cable failures in service are due to such damages. It may be necessary to inspect the underside with a mirror. In such cases it is advisable to make a first inspection whilst the cable is still on rollers.

DO NOT ATTEMPT COILING  
OF CABLE ON THE GROUND

FIG - 14



ON THE GROUND CABLE CAN BE FLAKED  
IN A FIGURE OF EIGHT FORMATION

FIG - 15

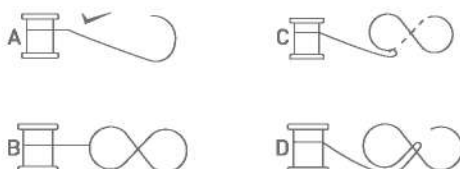

## **BREAKING BARRIERS IN THE INDUSTRY**

Pakistan Cables is proud to introduce the nation's highest voltage grade -69 kV CCV line -for Medium Voltage cables with world class German technology.



# REVOLUTIONIZING TRANSMISSION WITH TECHNOLOGY

**ACCC Conductors** - Our high-capacity, low-sag ACCC Conductors enable greater current-carrying capacity with lower line losses—ideal for grid upgrades, long spans, and energy-efficient power delivery.



# MAKE THE SWITCH.

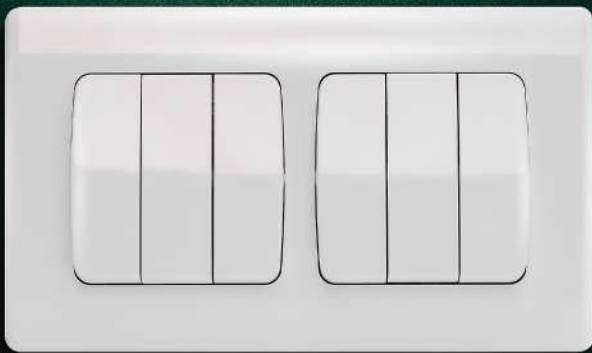

Pakistan Cables Wiring Accessories are a versatile range of world class electrical switches with superior quality and exquisite designs.

# PEHAL KARNE MEIN SABSE AAGAY

E-STORE NOW DELIVERING IN



C I T I E S O F P A K I S T A N



[www.pakistancables-estore.com](http://www.pakistancables-estore.com)

 **Head Office:** Arif Habib Centre, 1st Floor, 23 M.T Khan Road,  
Karachi - 74000, Pakistan

 [pakistancables.com](http://pakistancables.com)

 +92-21-111-CABLES (222-537)

 [info@pakistancables.com](mailto:info@pakistancables.com) | [sales@pakistancables.com](mailto:sales@pakistancables.com) | [export@pakistancables.com](mailto:export@pakistancables.com)

