

ALUMEX

Aluminium Sections for Architectural Applications



PRODUCT CATALOGUE



TRUSTED NOT TO COMPROMISE

Contents

About Us	01
Color Spectrum/Features & Benefits	02
Weights & Measures	03
Chemical Composition & Mechanical Properties	04
Tolerance Levels	05-09
Box Series Sliding Door/Window Sections	10-11
Semi Box Series Sliding Door/Window Sections	12
Collar Series Sliding Door/Window Sections	13
Fixed & Openable (Hinged) Door / Window Sections	14-15
Double Glazed Sliding Door/Window Sections	16-18
Color Series Double Glazed Sliding Door/Window Sections	19
Double Glazed Openable Door / Window Sections	20-23
Double Glazed Openable Door Sections	24
Deluxe Fixed Glazing/Shop Front Sections	25

Economy Fixed Glazing/Shop Front Sections	26
Semi Deluxe Fixed Glazing/Shop Front Sections	27
Fixed & Openable (Hinged) Door/Window Sections	28
Deluxe Swing Door Sections	29-32
Deluxe Sliding Door/Window Sections	33-34
Super Deluxe Sliding Door/ Window Sections	35-36
Semi Deluxe Sliding Door/Window Sections	37
Openable Door Section-5"	38
Hinged Door Section-4"	39
Hinged Door Section-3"	40
Hinged Door Section-3" Normal	41
Curtain Wall Sections	42-49
Curtain Wall Accessories	50-51
Dual Bonding Structural Glazing	52
Facade Openable Window Sections	53
Sunbreakers	54
Miscellaneous	55-61
Seismic Sections	62
Seismic Expansion Joint	63-64







About Us

ALUMEX® is the brand name under the parent umbrella brand of Pakistan Cables Limited, under which Aluminium sections and profiles for architectural, construction and industrial applications are manufactured. Alumex® sections are extruded from premium quality imported AA 6063 billets which is the internationally recommended grade for architectural and structural applications. These sections are anodised on a fully automated plant. Anodised sections are offered in four different color, while powder coated sections are available in any imaginable color to match the taste of the customer and for a wide range of applications.

Pakistan Cables the country's oldest and most reputable cable manufacturer, was established in 1953 as a joint venture with British Insulated Callender's Cables (BICC). In the subsequent six decades, the company earned a reputation as the market leader and premier cable manufacturer in the country. As the only wires and cables manufacturer in Pakistan listed on the Pakistan Stock Exchange, the company is renowned for its commitment to ethics and business excellence. Between 2010 and 2017, the company was affiliated with General Cable, a world leader in the cable industry and a Fortune 500 Company headquartered in the United States.

Pakistan Cables is ISO 9001:2015, ISO 14001:2015 and OHSAS 18001:2007 certified and was the first company in Pakistan to have its cables type tested by the world renowned KEMA Laboratory in Netherlands.

Color Spectrum

Natural	
Bronze	
Champagne	
Black	

Plus

Wide Range of Polyester Powder Coated Color

Features & Benefits:

Uniform Color & Pleasing Aesthetics
Smooth Finish
Scratch Free & Corrosion Resistant
Strength & Durability
No Extrusion Defects

Weights & Measures

Metric Measures and Equivalents

LENGTH

1 millimetre (mm)		=0.0394 in
1 centimetre (cm)	=10mm	=0.3937 in
1 meter (m)	=100cm	=1.0936 yds
1 kilometre (km)	=1000m	=0.6214 mile

SURFACE OR AREA

1 sq.cm (cm ²)	=100mm ²	=0.1550sq in
1 sqmetre (m ²)	=10,000cm ²	=101960 sq.yds
1 are (a)	=100m ²	=119.60 sq yds
1 sq.km (km ²)	=100hectares	=0.3861 sq miles

CAPACITY

1 cu cm (cm ³)	0.0610 cu in	
1 cu decimetre (dm ³)	1000cm ³	=0.0351 cu n
1 cu metre (m ³)	1000dm ³	=1.3080 cu yds
1 litre (l)	1dm ³	=0.2642 US gallon
1 hectilitre (hl)	100litres	=2.7497 bushels

WEIGHT

1 milligramme (mg)	=0.0154 grain		
1 gramme (g)	=1000mg	=0.0353 0%	=0.017 chattak
1kilogramme (kg)	=1000g	=2.2046lb	=1.07 seers
1 tonne (t)	=1000kg	=0.9842 ton	=26.75 maunds

British Measures and Equivalents

LENGTH

1 inch	=2.54 cm	
1 foot	=12 inches	=0.3048m
1 yard	=3 foot	=0.9144m
1 rod	=55 yards	=5.0292m
1 chain	=22 yards	=20.117m
1 furiiong	=220 yards	=201.17m
1 mile	=1760 yards	=1.6093km
1 nautical mile	=6080 feet	=1.853km

SURFACE/AREA

1 sq inch	=6.4516 cm ²	
1 sq foot	=144 sq.inches	=0.0929m ²
sq . yard	=9 sq . feet	=0.8361m ²
1 acre	=4840 sq . yards	=4046.9m ²
1 sq . mile	=640 acres	=259.0 hectares

CAPACITY

1 cu inches	=16.387 cm ³	
1 cu foot	=1728 cu inches	=0.0283m ³
1 cu yard	=27 cu feet	=0.7646m ³
1 pint	=4 gills	=0.5683 litre
1 quart	=2 pints	=1.1365 litre
1 imperial gallon	=8 pints	=4.5461 litre
1 bushel	=8 gallons	=36.369 litre

APOTHECARIE

1 fuild ounce	=8 fl drams	=28.413 cm ³
1 pint	=20 fl ounce	=568.26 cm ³

WEIGHT

aveirdupols		
1 tola	=0.41 ounces	=11.6363 g
1 ounce	=437.5 grains	=28.350 g
1 pound	=16 ounce	=0.4536 kg
1 seer	=14 pounds	=6.3503 kgs
1 hundredweight	=112 pounds	=50.802 kgs
1 ton	=20 cwt	=1.0161 tonnes

USA Dry Measure Equivalents

1 pints	=0.9689 UK pt	=0.5506 litre
1 bushel	=0.9689 UK bu	=35.238 litres

USA Liquid Measure Equivalents

1 fluid ounce	=1.0408 UK fl oz	=0.0296 litre
1 pint (16 oz)	=0.8327 UK pt	=0.4732 litre
1 gallon US	=0.8327 UK gal	=3.7853 litres
1 barrel	=42 US Gallons	=158.98 litres

THERMOMETER COMPARISON

$$E = 2 \times C$$

$$C = (F-32) \times 5/9$$

$$F = C \times 9/5 + 32$$

Fever Chart

E	F	C
81.0	105	40.5
80.0	104	40
78.0	103	39.4
77.6	102	38.8
76.6	101	38.3
75.4	100	37.7
74.0	98.6	37
72.2	97	36.1

	Fahrenheit	centigrade	Enviroment
water freezes	32	0	0
water boils	212	100	200
absolute zero	-459.6	-273.15	-546.3
maxglobe human env	122	50	100

(Hypothetically the lowest, possible temperature at which all motion would cease.)

E	F	C
100	122	50
90	113	45
80	104	40
70	95	35
60	86	30
50	77	25
40	68	20
30	59	15
20	50	10
10	41	5
0	32	0
-10	23	-5
-20	14	-10
-30	5	-15
-35.6	0	-17.8
-40	-4	20
-50	-13	-25

Pakistan Cables has been manufacturing aluminium sections for architectural and industrial uses under the brand name of **ALUMEX** for the last three decades.

ALUMEX sections are extruded from imported premium quality billets of aluminium alloy AA6063, the internationally recommended alloy for structural applications. This conforms to ASTM-B221 and BSEN 12020-2: 2008. Chemical composition and properties of AA6063 are given below.

Chemical Composition A/sa

Mg	0.45-0.90
Si	0.20-0.60
Cr	0.10
Zn	0.10
Fe	0.35
Cu	0.10
Mn	0.10
Ti	0.10
Other impurities	0.05
Aluminium	Remainder

Mechanical Properties

		T5 Condition	T6 Condition
Ultimate Tensile Strength	N/mm ²	150	205
0.2% Proof Stress	N/mm ²	110	160
Hardness (Brinell)	BHN	55	65
Ultimate Shear Strength	N/mm ²	155	125
Elongation on 50mm	%	8	12
Density	g/cm ³	2.7	2.7
Melting Point	Deg.C	600	650
Coefficient of Linear Expansion	X1/Deg.C	23	23
Modulus of Elasticity	N/mm ²	67000	67000
Fatigue Strength (50x10) 6 Cycle	N/mm ²	75	70

The extrusion is performed on a 2000 ton (8' dia) Schloemann extrusion press, the best aluminium extrusion plant in the business. Aluminium sections are anodized on a fully automatic plant with very high quality German origin chemicals in accordance with BS 3987-1991, SSEN 12373-1 - 2001. Normally the sections are produced and supplied in T5 condition, the most ideal condition for architectural and structural applications. However, we can also produce sections in T6 condition, if desired by the customer.

ALUMEX sections are available in elegant anodized colors as well as wide range of powder coated colors for complete architectural & structural applications. We also manufacture profiles to cater for clients' specific requirements.

Pakistan Cables also has facility for powder coating of aluminium sections. Unlike others, we offer durable polyester (Facade grade) and super durable polyester powder, thermosetting type formulated to satisfy the requirements of the architectural applications with regard to aesthetics, color variety, UV and humidity resistance in accordance with BS 6496 (1984) & AMMA 2604.

Pakistan Cables became the first company in Pakistan to be certified for ISO 9001:2000 for manufacturing & marketing of aluminum extrusions. It is also the first company to be upgraded to ISO 9001:2008. Pakistan Cables has also obtained certification of HSE Management Systems conforming to OHSAS 18001 & ISO 14001.

Tolerance On Thickness of Solid Sections

Width Across Flatness of Bar or Width of the Section		Tolerance on Specified Thickness (Plus and minus)				
		Up to and including 1.6mm thick	Over 1.6mm up to and including 3mm thick	Over 3mm up to and including 6mm thick	Over 6mm up to and including 10mm thick	Over 10mm up to and including 18mm thick
Over	up to and including					
mm	mm	±mm	±mm	±mm	±mm	±mm
-	10	0.16	0.18	0.20	0.22	-
10	18	0.18	0.20	0.22	0.24	0.26
18	30	0.22	0.24	0.26	0.28	0.30
30	60	0.24	0.26	0.28	0.3	0.33
60	80	0.28	0.30	0.32	0.34	0.37
80	120	0.32	0.34	0.36	0.39	0.42
120	180	-	0.36	0.40	0.45	0.50
180	240	-	-	0.50	0.55	0.60

Tolerance On Thickness of Hollow Sections (Class A and B)

Width Across Flatness of Bar or Width of the Section		Tolerance on Specified Thickness (Plus and minus)					
		Class A					
Over	up to and including	Up to and including 1.6mm thick	Over 1.6mm up to and including 3mm thick	Over 3mm up to and including 6mm thick	Over 6mm up to and including 10mm thick	Over 10mm up to and including 18mm thick	Over 18mm up to and including 18mm thick
±mm	±mm	±mm	±mm	±mm	±mm	±mm	±mm
-	10			-			
10	18	0.2	0.22				
18	30	0.26	0.28	0.32	-	-	-
30	60	0.32	0.36	0.41	0.48	-	-
60	80	0.36	0.41	0.48	0.58	0.68	-
80	120	-	0.48	0.58	0.68	0.82	1
120	180	-	0.65	0.75	0.85	0.95	1.1
180	240	-	-	0.95	1.05	1.20	1.4
240	320	-	-	-	1.25	1.45	1.8

The tolerances apply to non heat treated sections of wall thickness not less than 1.6mm 3% of the overall width, whichever is greater, and heat treated sections of wall thickness not less than 1.6mm or 4% of the overall width, whichever is greater

Tolerance On Thickness of Hollow Sections (Class A and B)

Width Across Flatness of Bar or Width of the Section		Class A					
		Up to and including 1.6mm thick	Over 1.6mm up to and including 3mm thick	Over 3mm up to and including 6mm thick	Over 6mm up to and including 10mm thick	Over 10mm up to and including 18mm thick	Over 18mm up to and including 18mm thick
Over	up to and including	±mm	±mm	±mm	±mm	±mm	±mm
-	10			-			
10	18	0.22	0.28				
18	30	0.28	0.36	0.54	-	-	-
30	60	0.36	0.45	0.65	0.9	1.4	-
60	80	0.45	0.55	0.75	0.95	1.45	-
80	120	-	0.65	0.8	1	1.5	2
120	180	-	0.75	0.85	1.1	1.60	-2.2
180	240	-	-	1.00	1.2	1.80	2.4
240	320	-	-	-	1.4	2.00	2.6

Tolerance of twist

Circumscribing circle diameter of the section mm	Maximum angle of twist T per 300mm run degrees	Maximum total angle of twist per length degrees
Under s20	3	7
Over 20 up to and including 40	1	5
Over 40 up to and including 80	0.5	3
Over 80		
Lengths up to and including 8000mm	0.25	2
Lengths over 8000mm	0.25	3

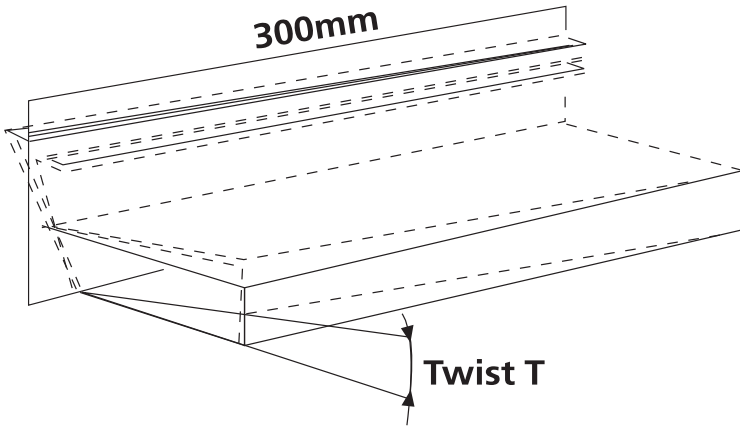

Tolerance on length for all materials supplied in fixed cut lengths

Width Across Flatness of Bar or Width of the Section		Tolerance on length for given length					
		Over 300mm up to and including 3000mm thick	Over 300mm up to and including 3000mm thick	Over 300mm up to and including 3000mm thick	Over 300mm up to and including 3000mm thick	Over 300mm up to and including 3000mm thick	Over 300mm up to and including 3000mm thick
Over	up to and including	±long mm	±long mm	±long mm	±long mm	±long mm	±long mm
-	60	2	2.5	2.5	3.5	4	6.5
60	100	2	2.5	3.5	4	5.5	7.5
100	140	3	3.5	4	5	6.5	8
140	180	3.5	4	5	6.5	8	9.5
180	240	4.5	5	6.5	8	9.5	11

Angular Tolerance

Width		Maximum Allowance Deviation, Z from a Right Angle
Over (mm)	Up to and Including	
-	30	0.4
30	50	0.7
50	80	1.0
80	120	1.4
120	180	2.0
180	240	2.6
240	300	3.1
300	400.0	3.5

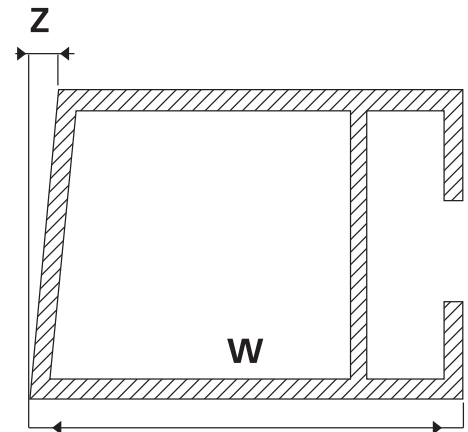

Flatness Tolerance

Tolerance on Concavity and Convexity				
Width		Deviation e		
Over	up to and including	Hollow Profiles a		Solid Profiles
		Wall Thickness t	Wall Thickness t > 5	
-	30	0.30	0.20	0.20
-	60	0.40	0.30	0.30
60	100	0.60	0.40	0.40
100	150	0.90	0.60	0.60
150	200	1.20	0.80	0.80
200	300	1.80	1.20	1.20
300	400	2.40	1.60	1.60
400	500	3.00	2.00	2.00
500	600	3.60	2.40	2.40
600	800	4.00	3.00	3.00

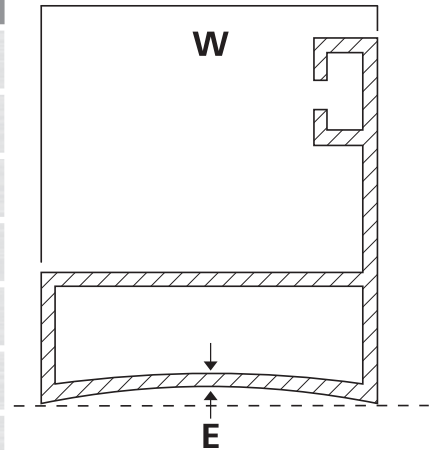

a if the profile has varying wall thickness in the measurement range, the thinnest wall thickness shall be used.

Straightness Tolerances

Section Length (L)	Up to 3000	Up to 4000	Up to 5000	Up to 6000	Over 6000	Localized Kink of 300 mm
Straightness Tolerance (SO) (mm)	1.8	2.2	2.6	3.0	3.5	0.3

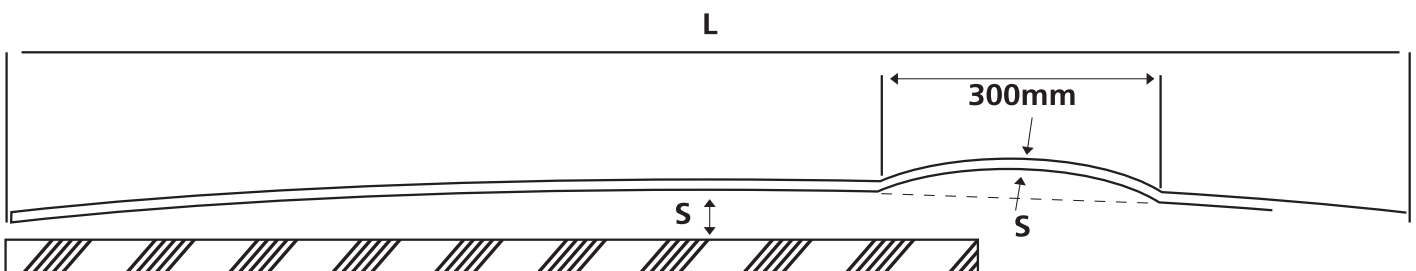

Tolerance of Diameter Or Width-Regular Solid And Hollow Sections

Diameter/Width (W)		Tolerance (mm)
Over (mm)	Up to and Including mm	
-	10	0.15
10	15	0.20
15	30	0.25
30	45	0.30
45	60	0.40
60	90	0.45
90	120	0.60
120	150	0.70
150	180	0.90
180	240	1.10

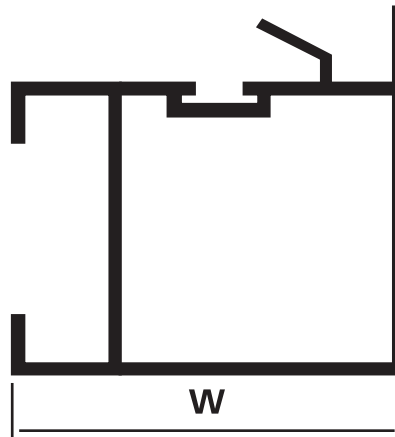

Box Series Sliding Door/Window Sections 1.2mm, 1.6mm, 2.0mm

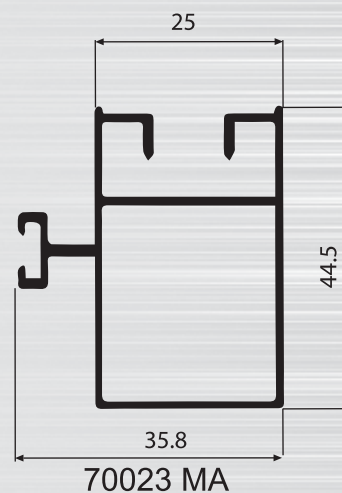
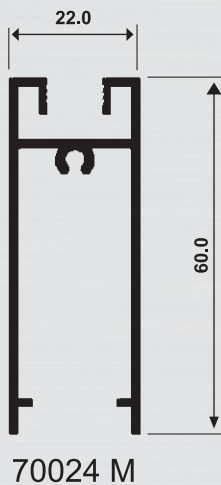
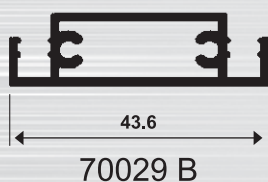
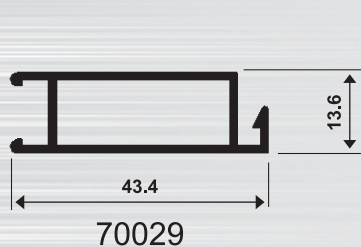
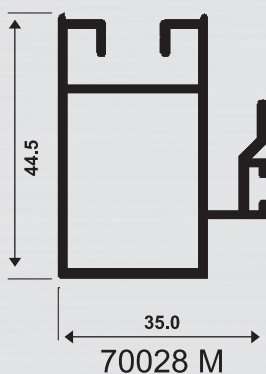
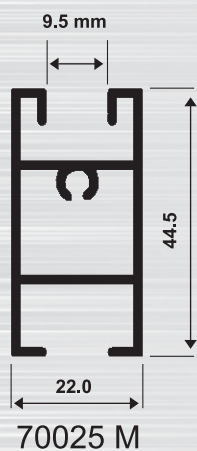
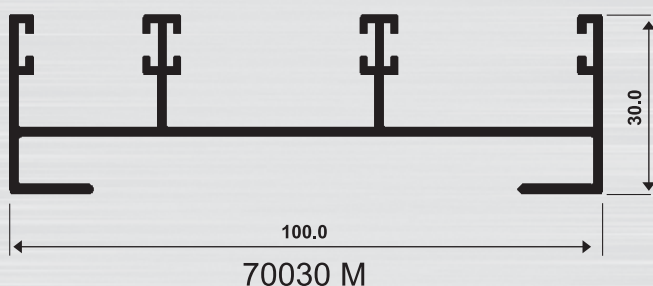
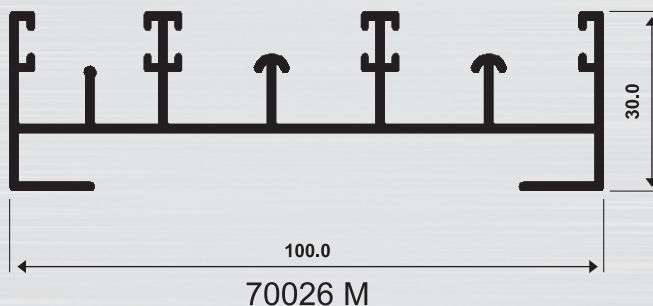

Box Series Sliding Door/Window Sections 1.2mm, 1.6mm

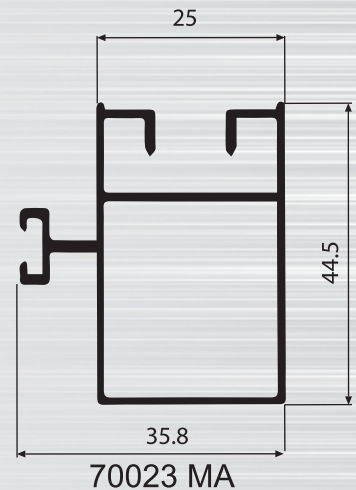
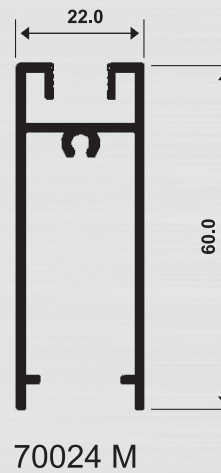
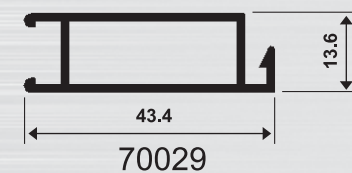
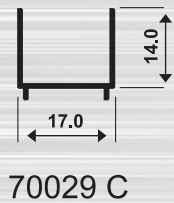
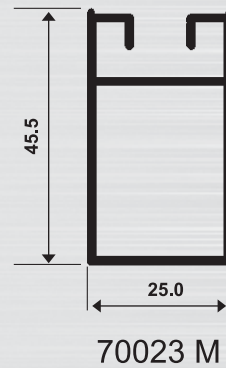
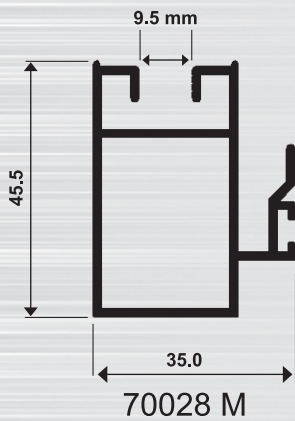
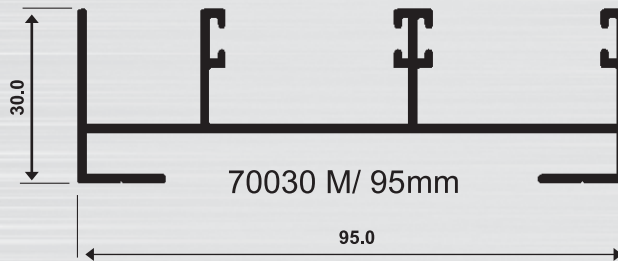
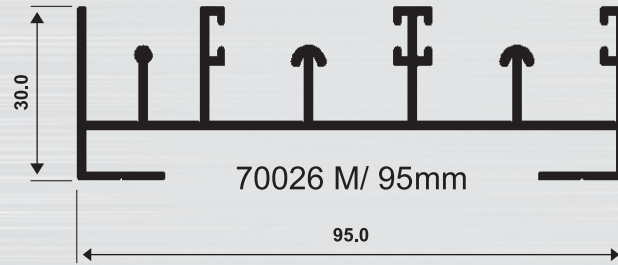

Semi Box Series Sliding Door/Window Sections 1.2mm

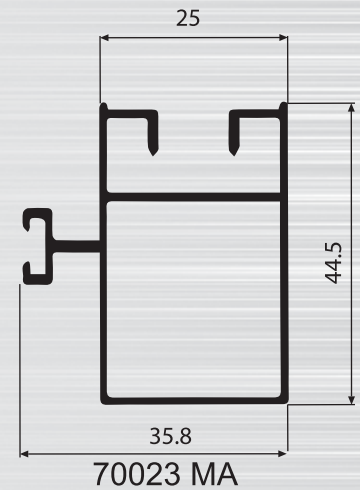
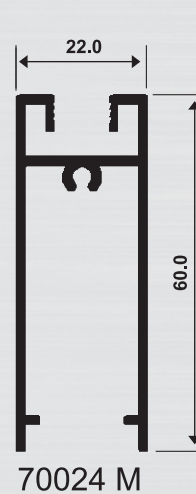
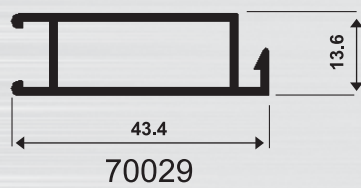
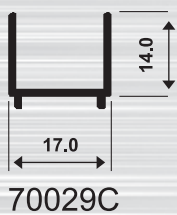
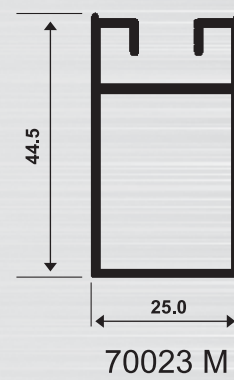
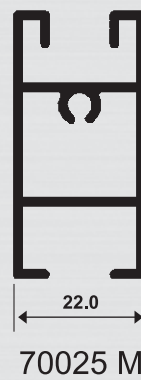
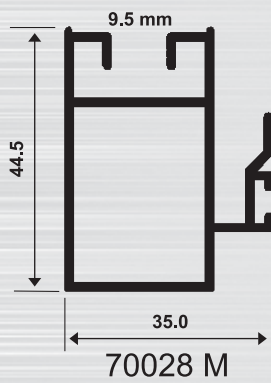
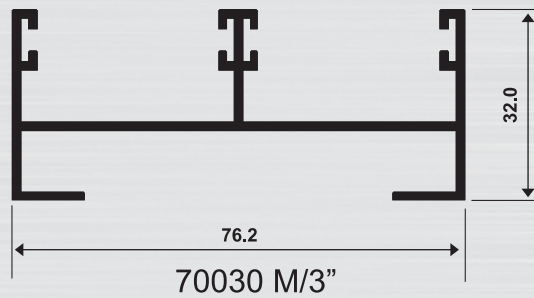
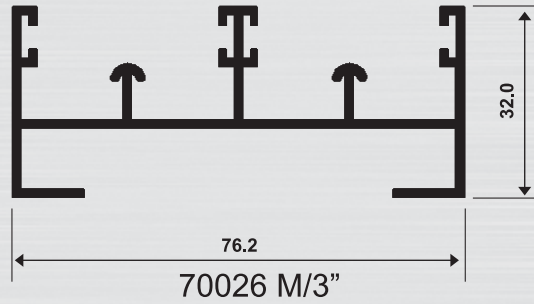

Collar Series Sliding Door/Window Sections 1.6mm, 1.2mm

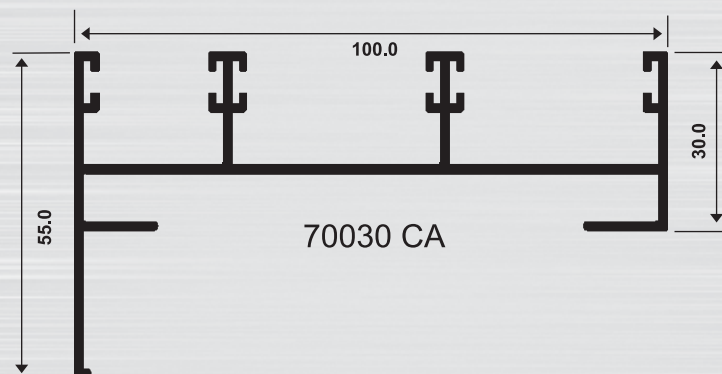
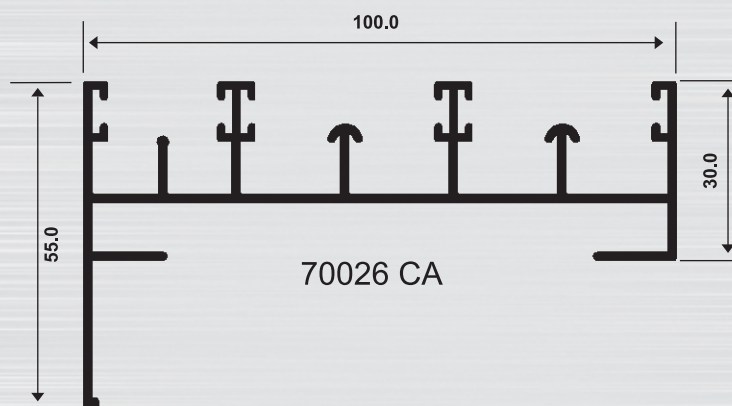
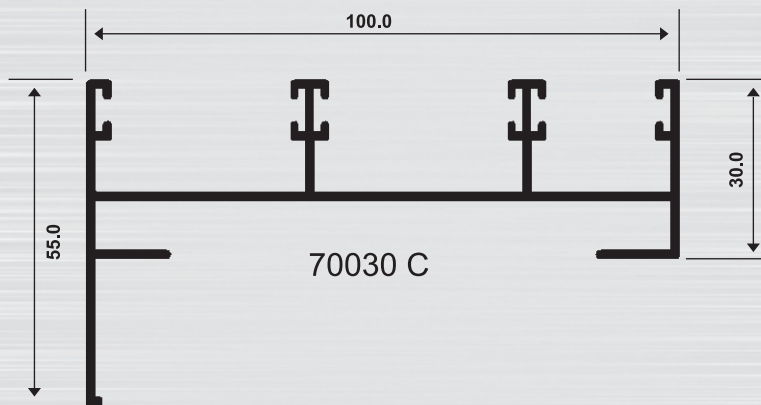
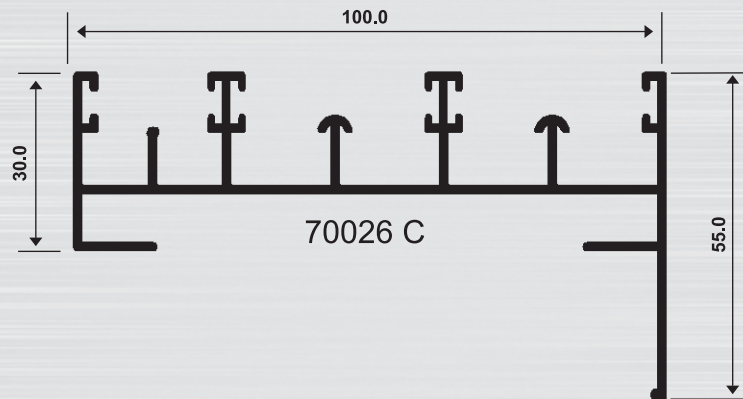

Fixed & Openable (Hinged) Door/ Window Sections

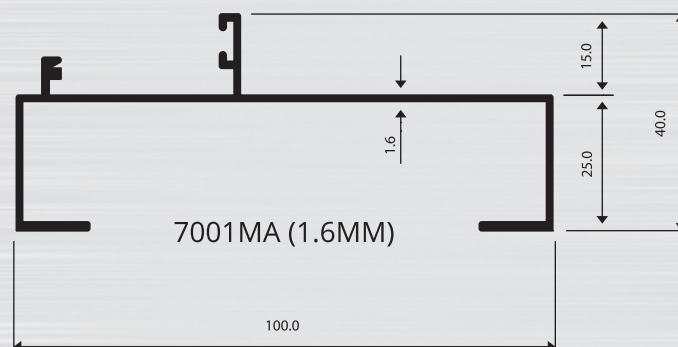
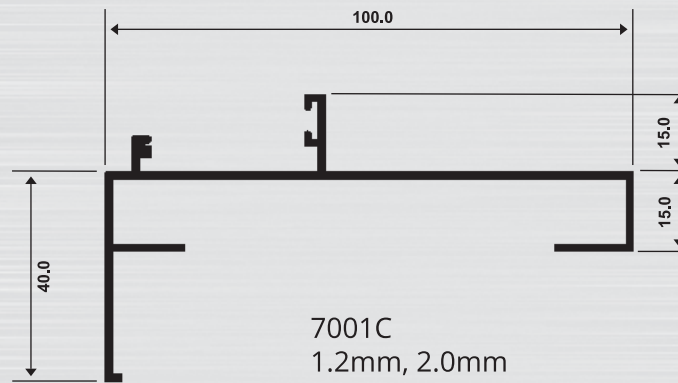
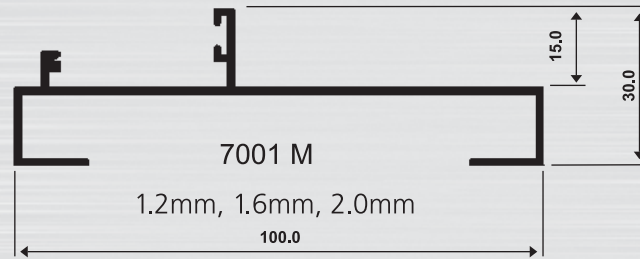
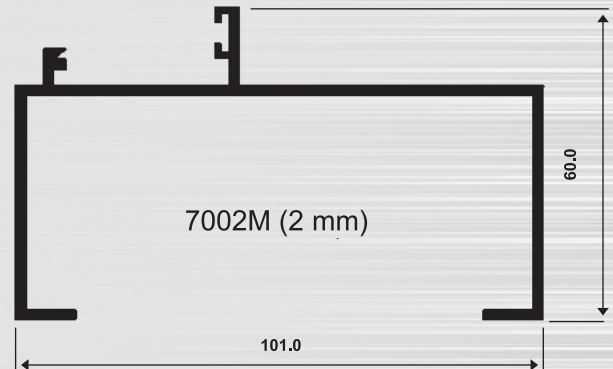
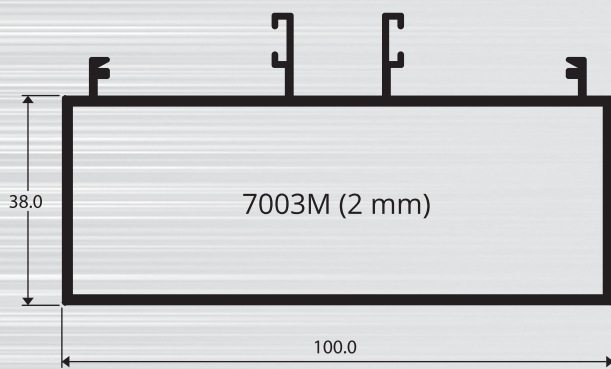

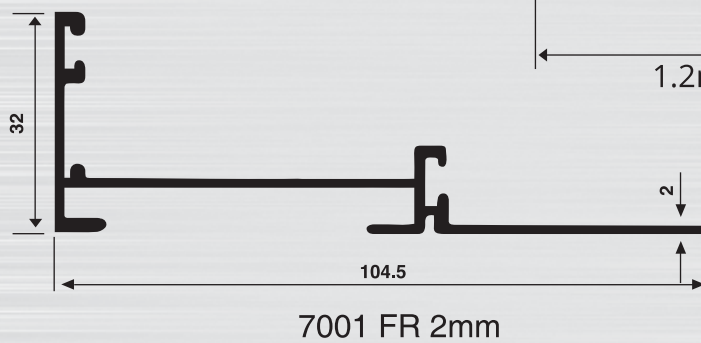
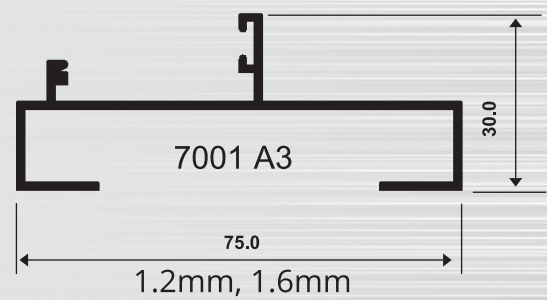
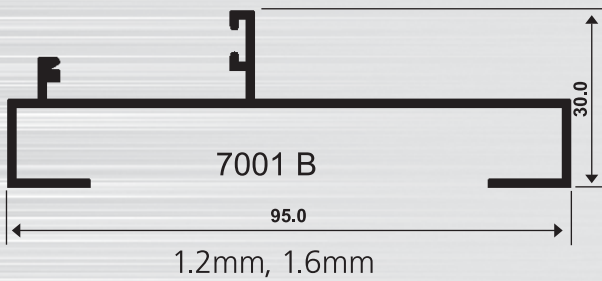
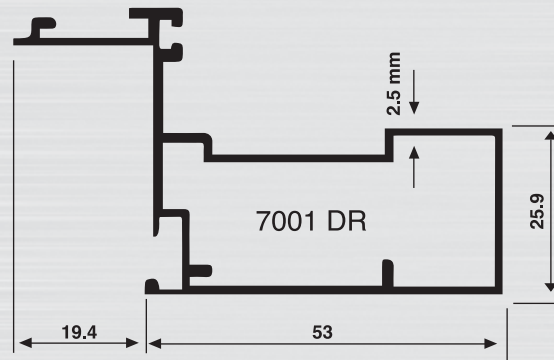
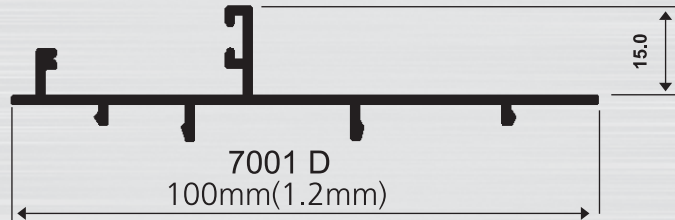

Double Glazed Sliding Door/ Window sections 1.6mm & 2mm

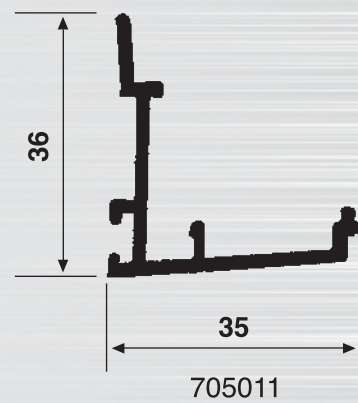

Double Glazed Sliding Door/Window Sections 1.6mm & 2.0mm

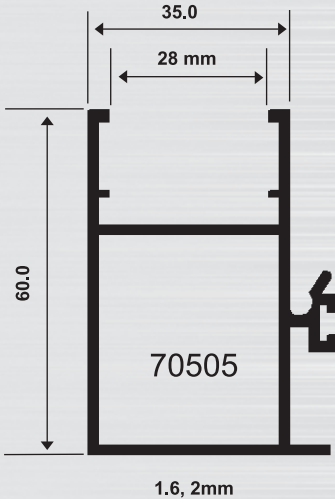
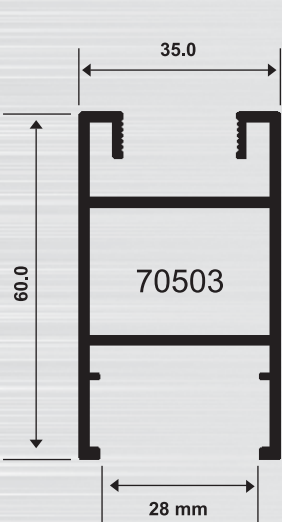
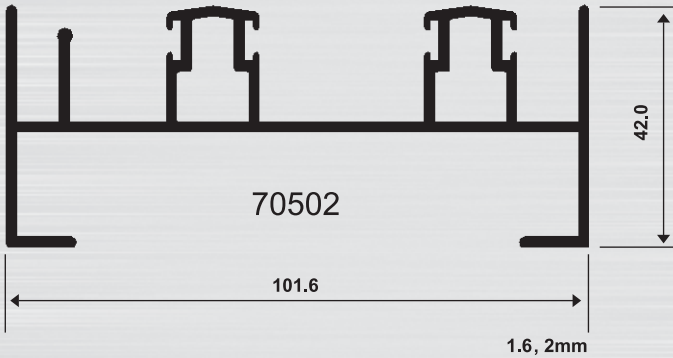
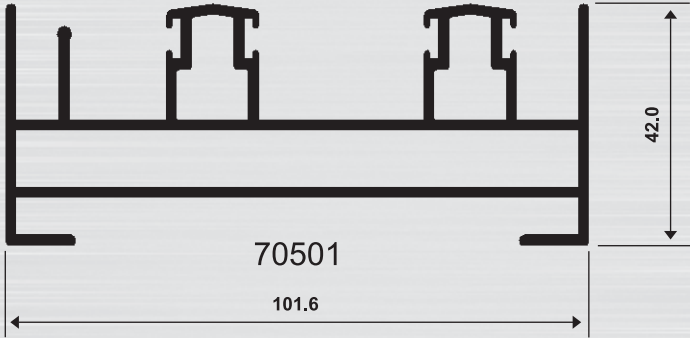

Double Glazed Sliding Door/Window Sections 1.6mm & 2.0mm

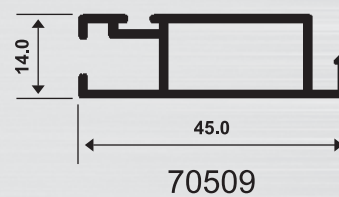
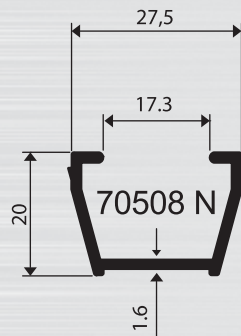
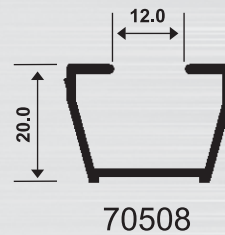
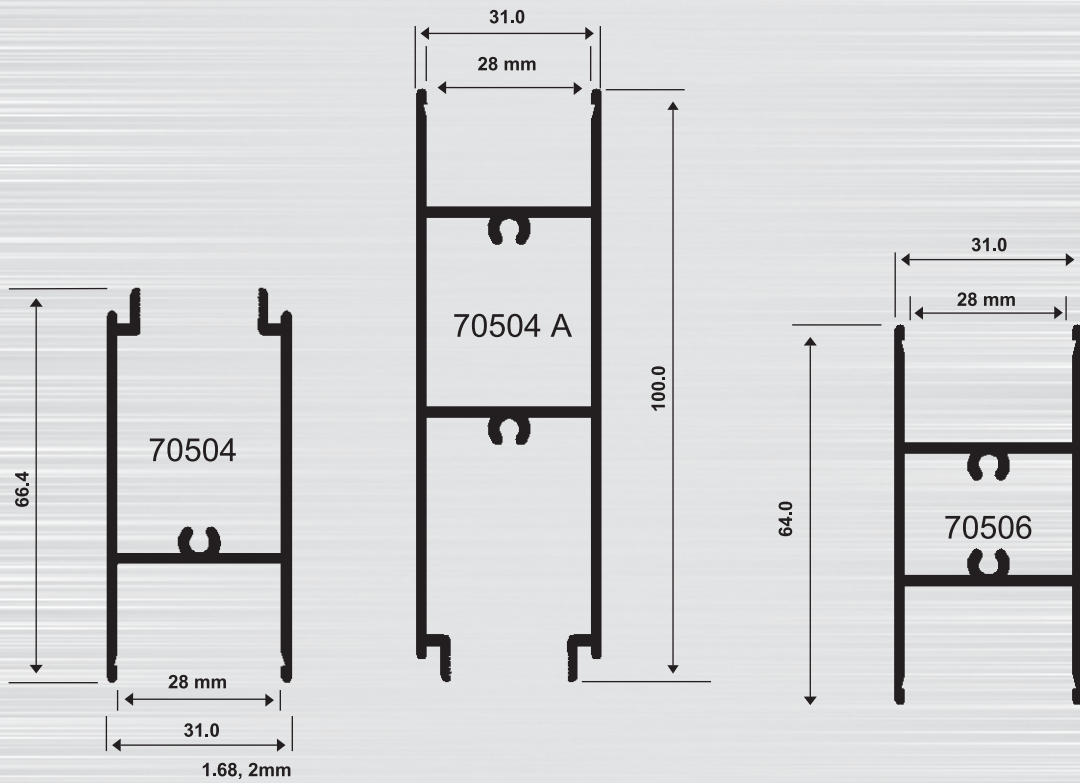

Color Series Double Glazed Sliding Door/Window Sections 1.6mm

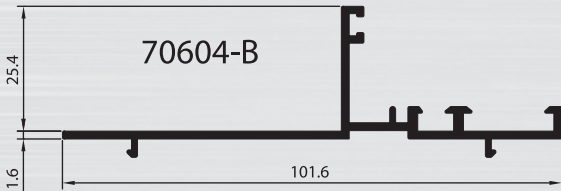
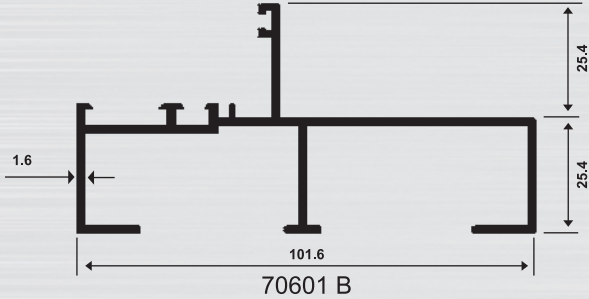
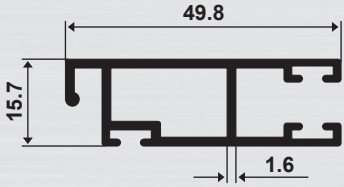
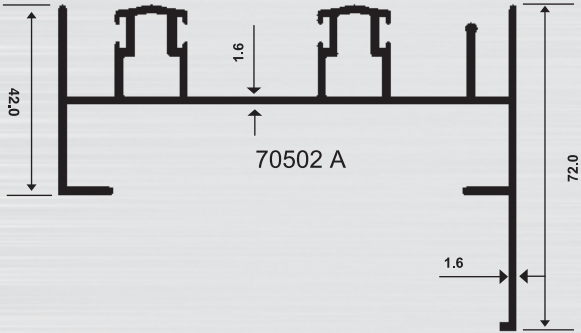
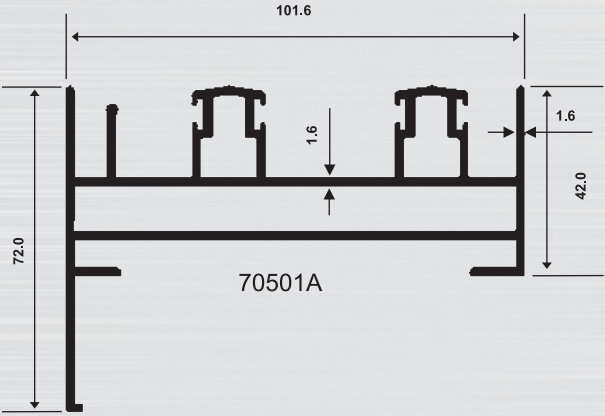

Double Glazed Openable Door/Window Sections 1.6mm & 2.0mm

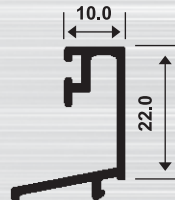
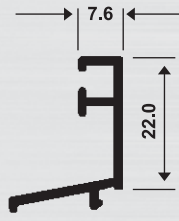
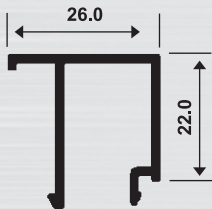
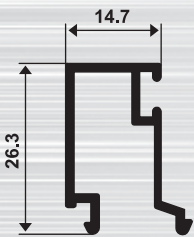
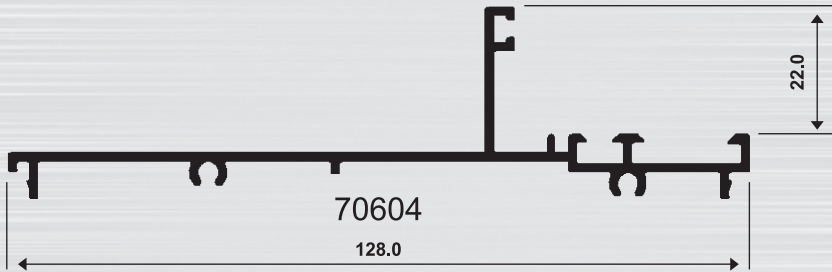
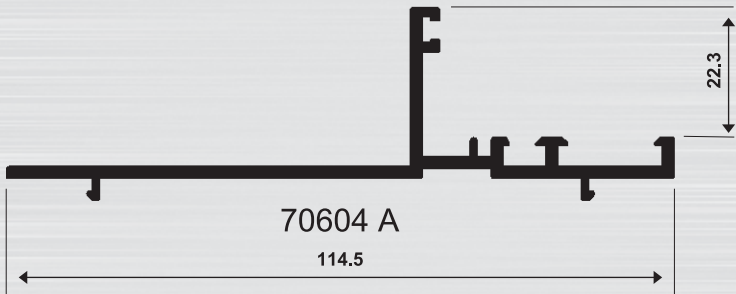
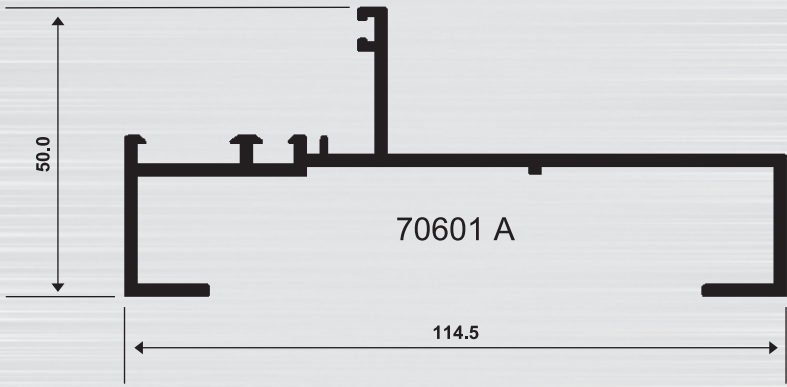
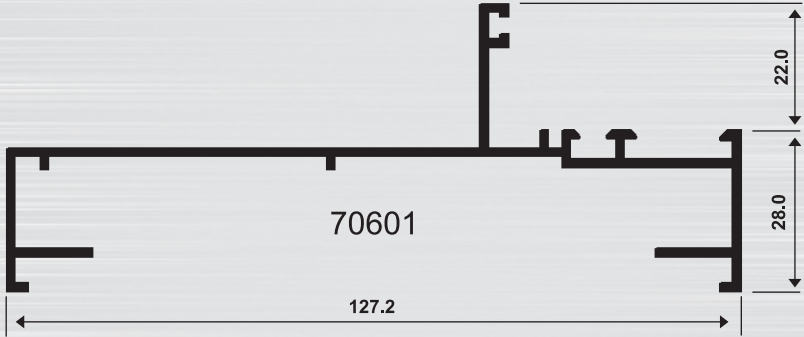

70605 A

70605

70606 A

70606

Double Glazed Openable Door/Window Sections 1.6mm & 2.0mm

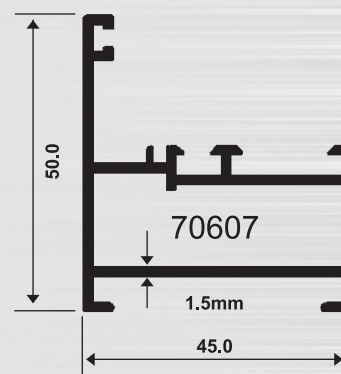
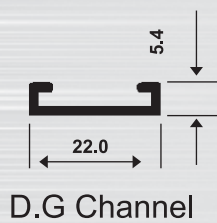
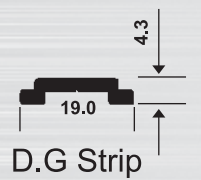
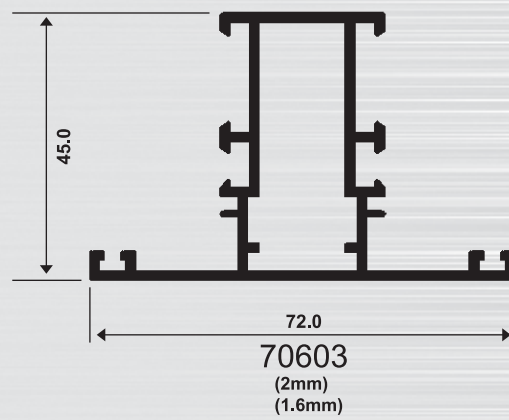
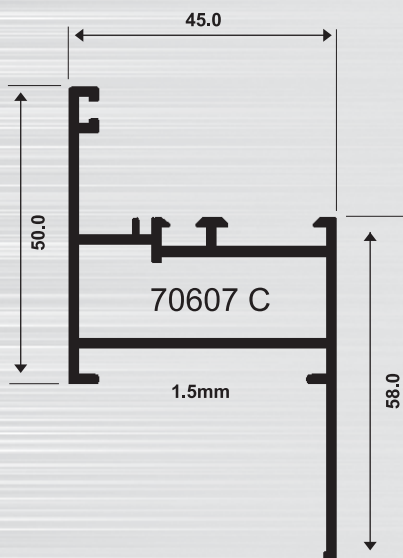
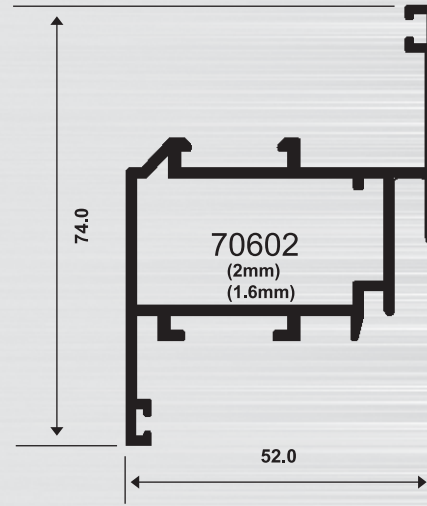
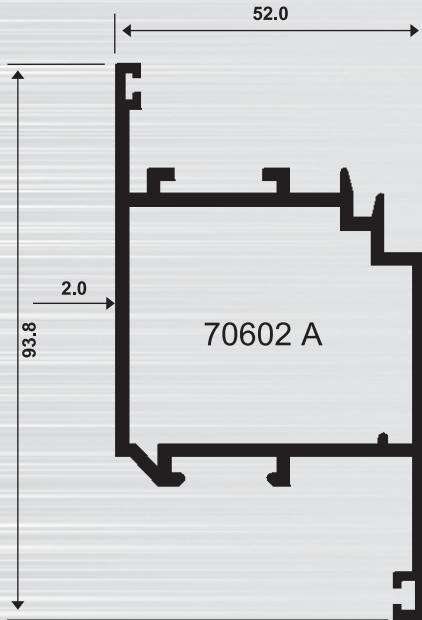

Double Glazed Openable Door/ Window Sections

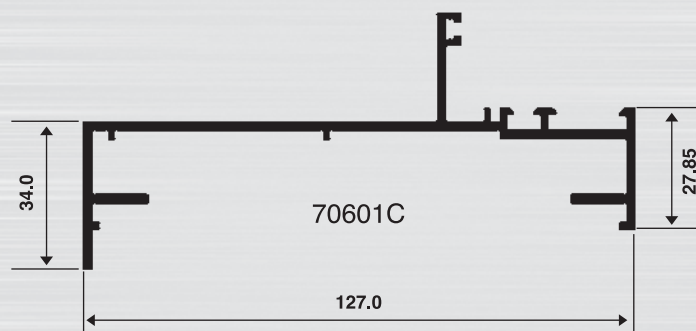
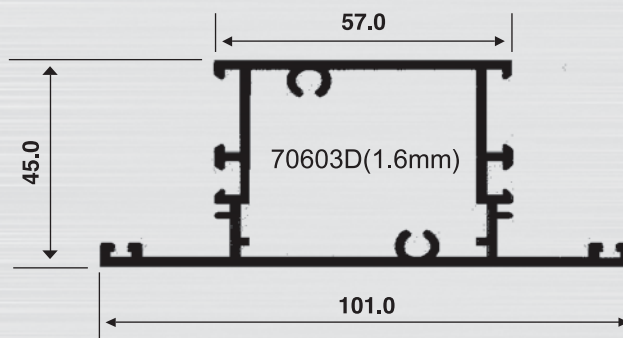
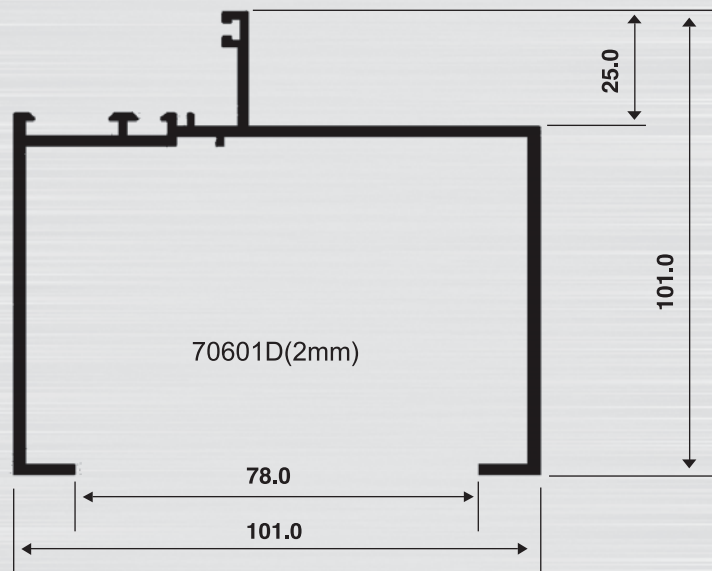
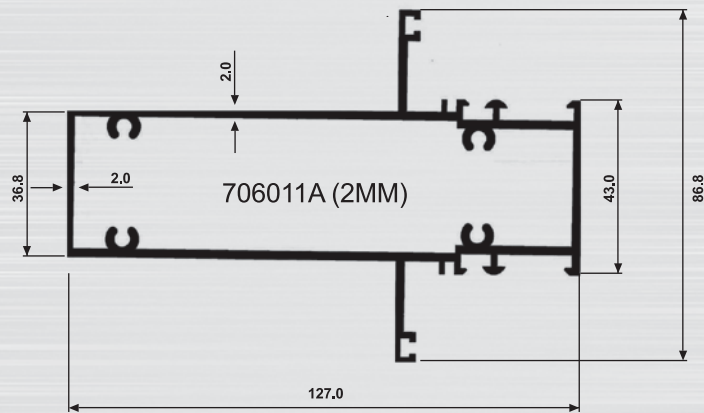

Double Glazed Openable Door/ Window Sections 1.6mm

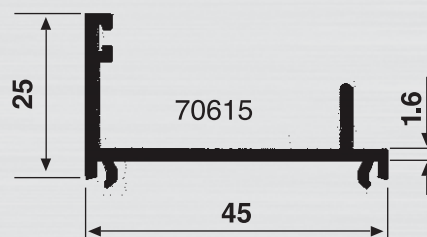
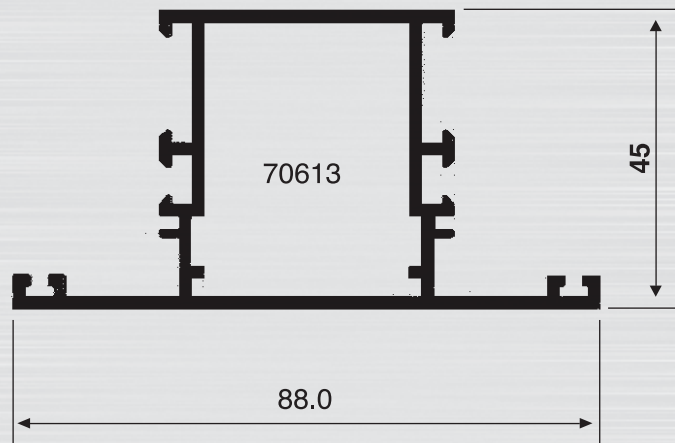
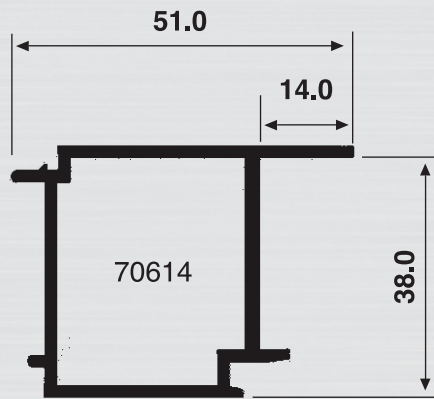

Double Glazed Openable Door Sections

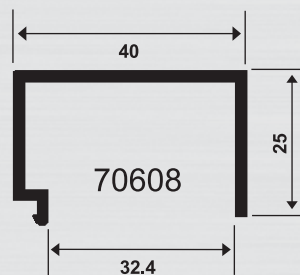
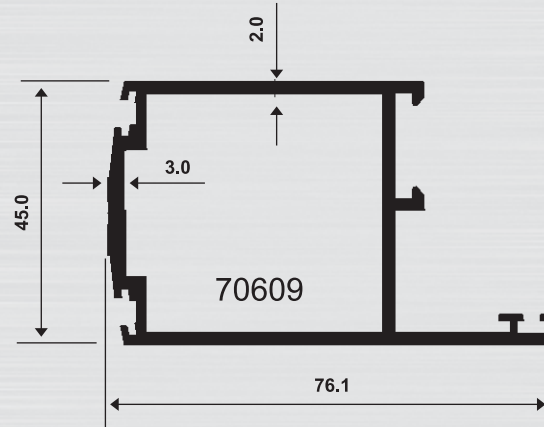
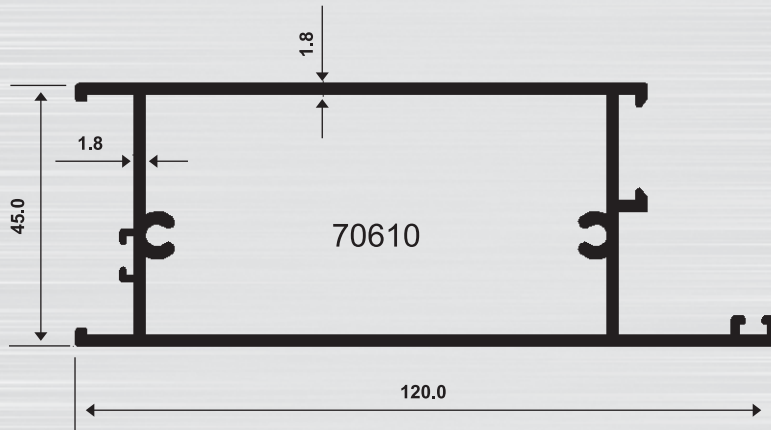

Deluxe Fixed Glazing/Shop Front Sections 1.2mm, 1.6mm, 2.0mm

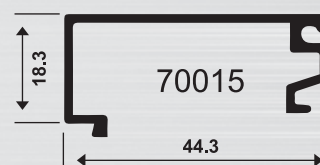
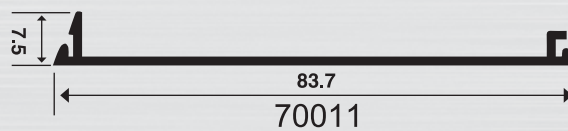
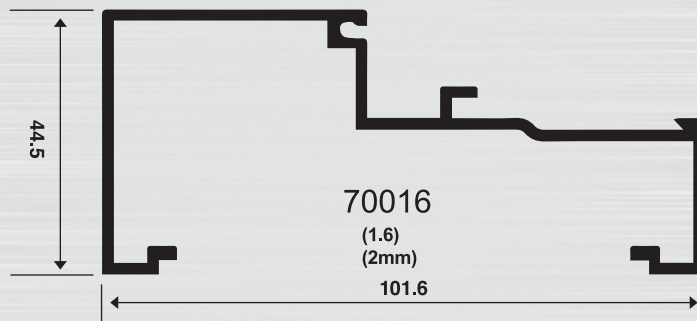
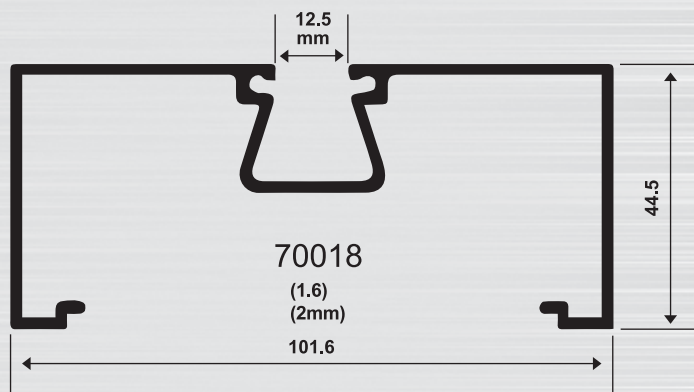
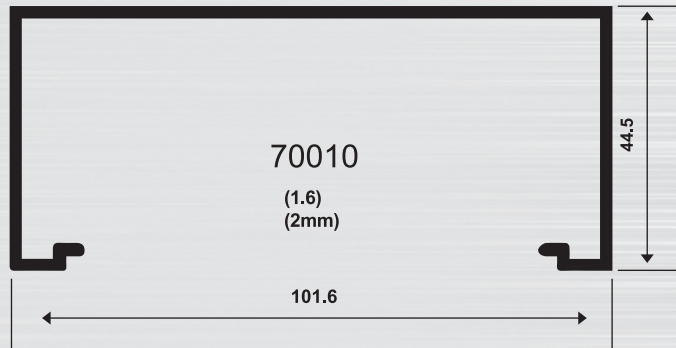

Economy Fixed Glazing/Shop Front Sections 1.2mm

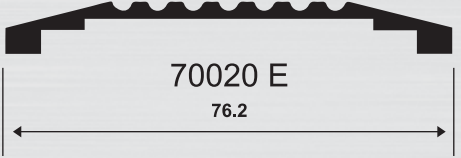
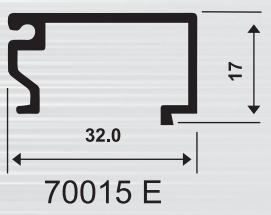
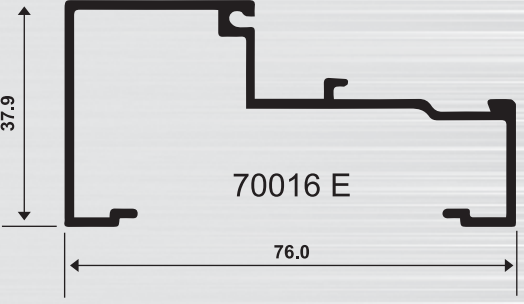
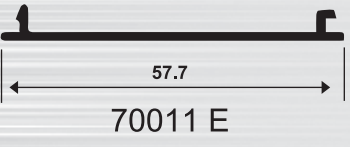
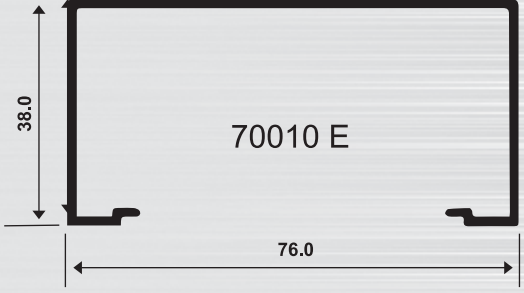

Semi Deluxe Fixed Glazing/Shop Front Sections 1.6mm

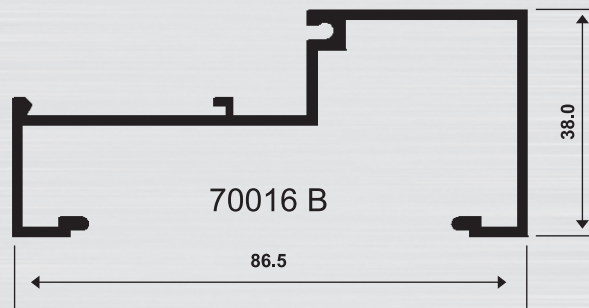
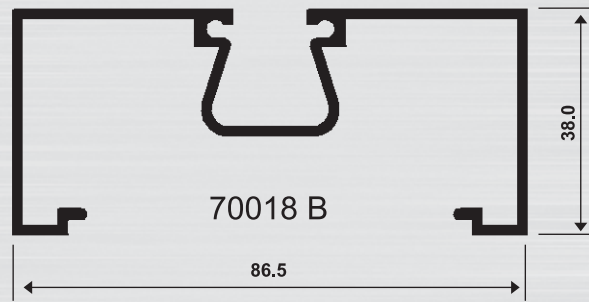

Fixed & Openable (Hinged) Door/ Window Sections

1.2 mm, 1.6mm, 2.0mm

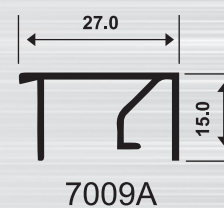
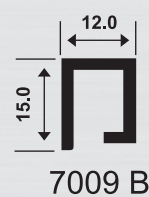
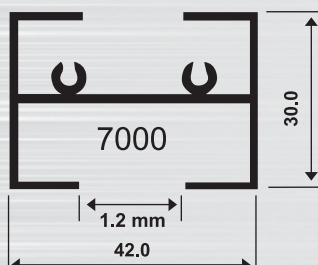
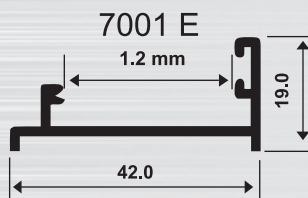
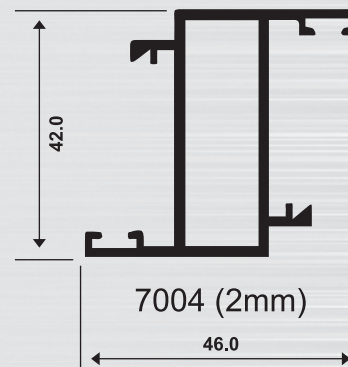
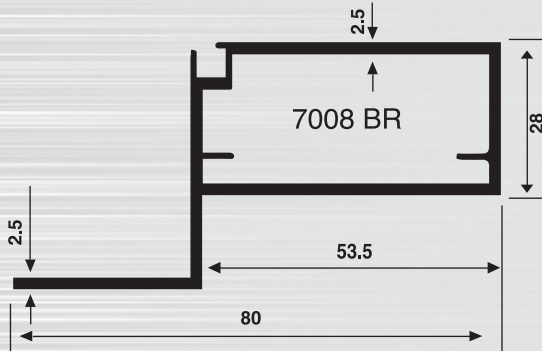
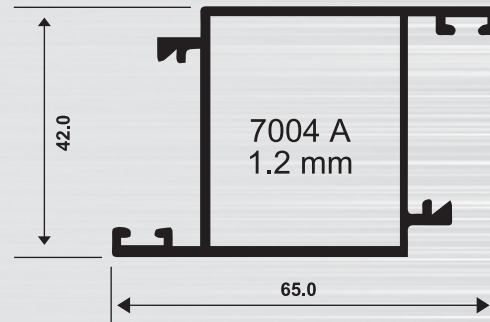
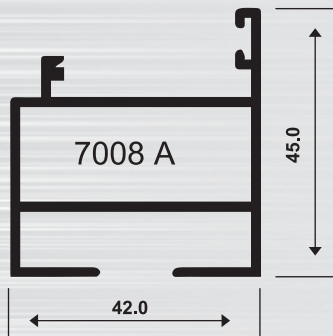
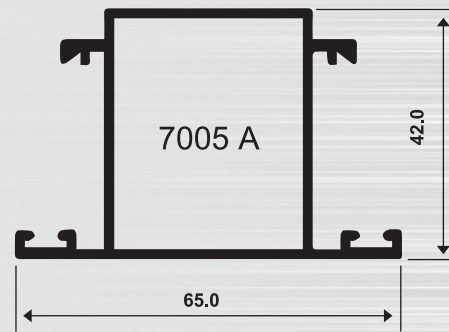
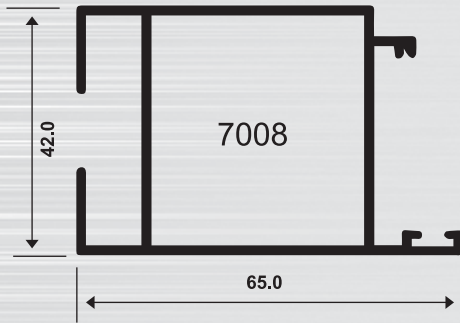

Deluxe Swing Door Sections 1.2mm

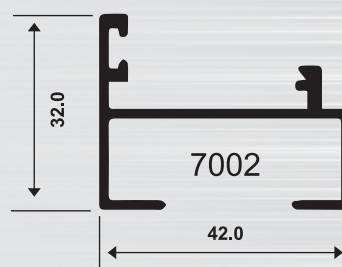
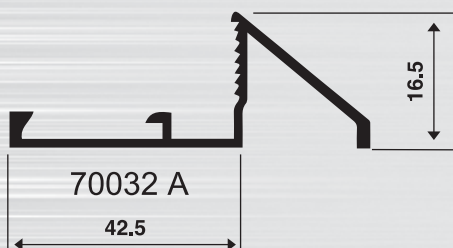
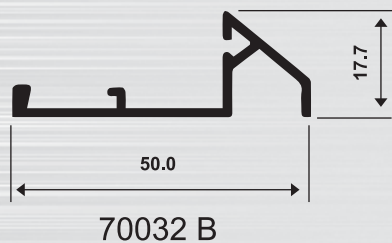
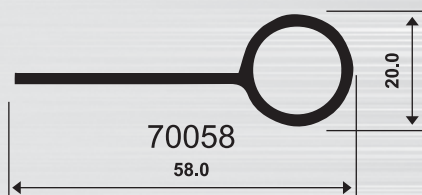
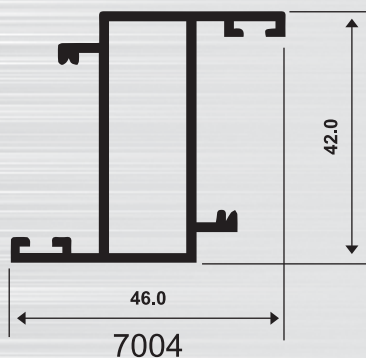
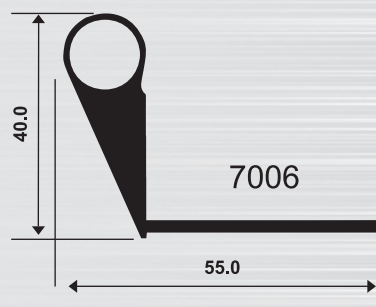
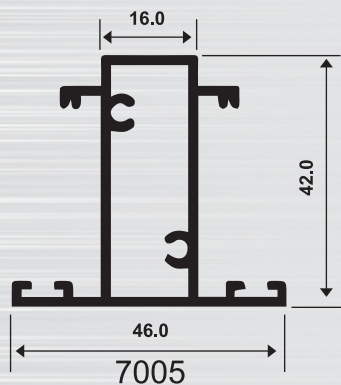

Deluxe Swing Door Sections

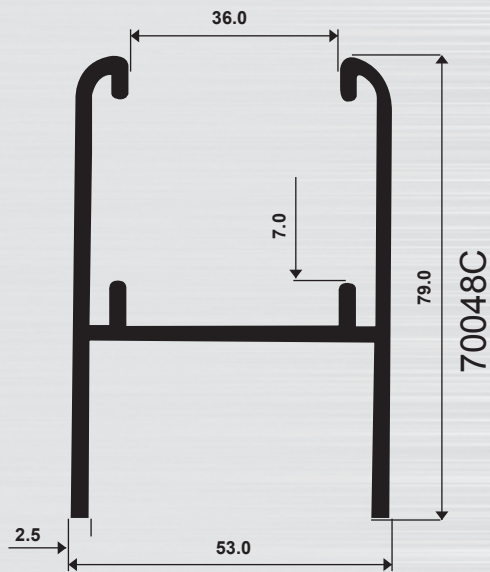
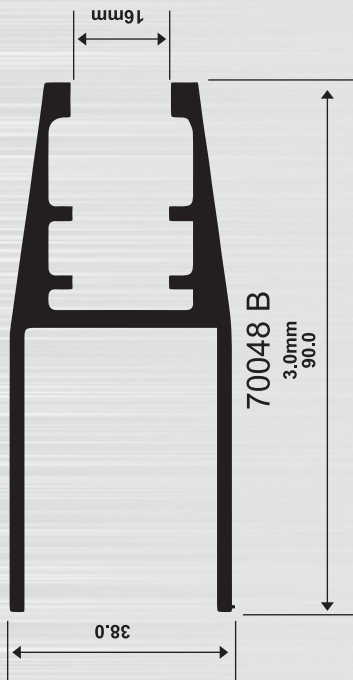
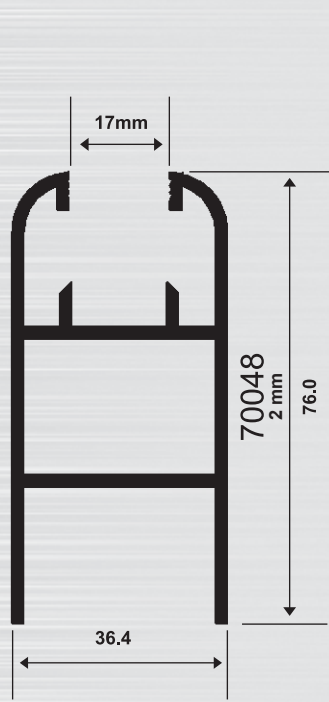

Deluxe Swing Door Sections

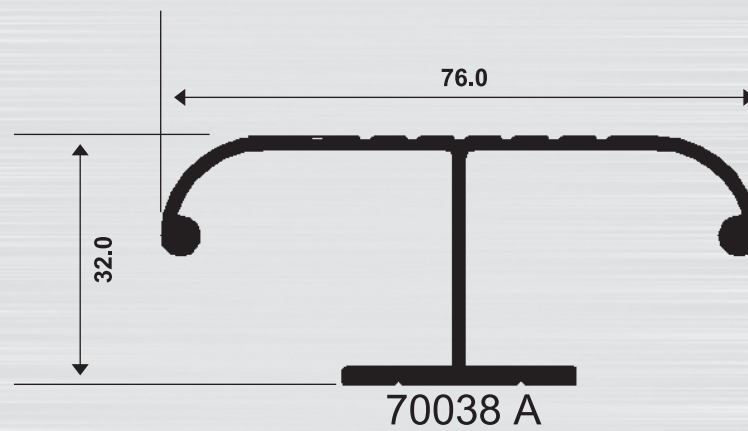
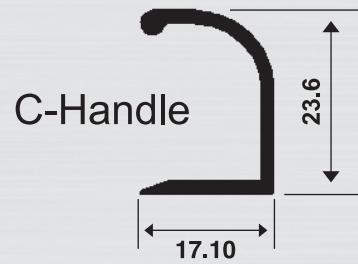
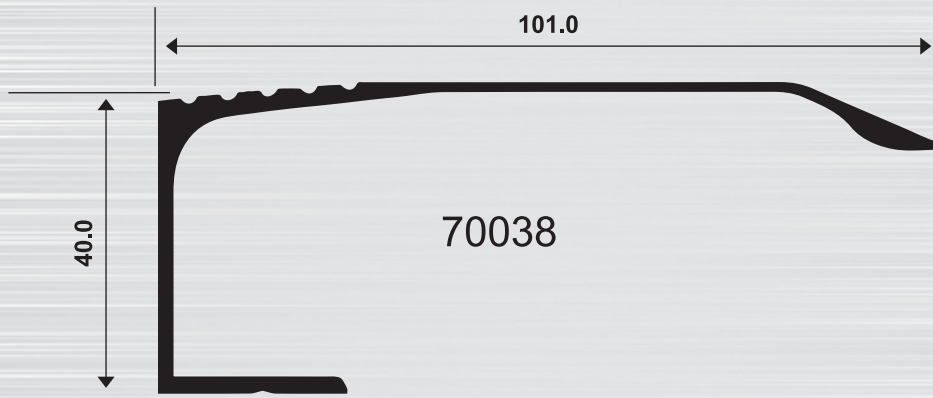

Deluxe Swing Door Sections 1.2mm, 1.6mm, 2mm

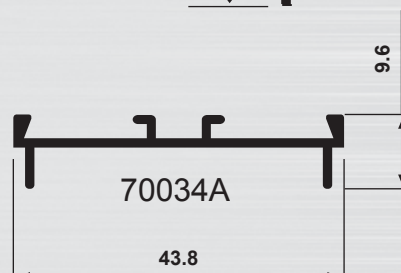
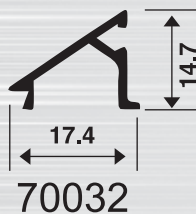
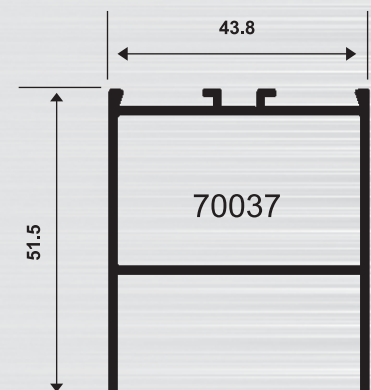
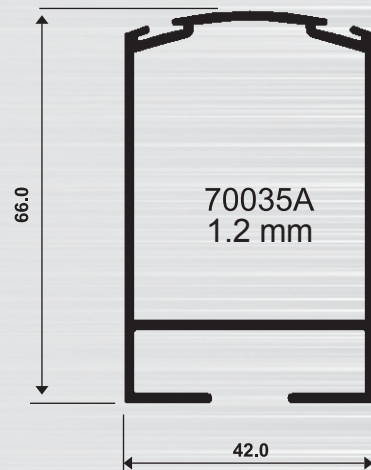
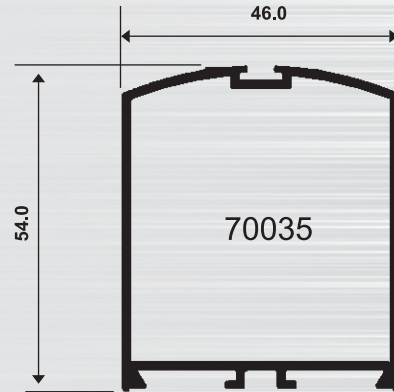
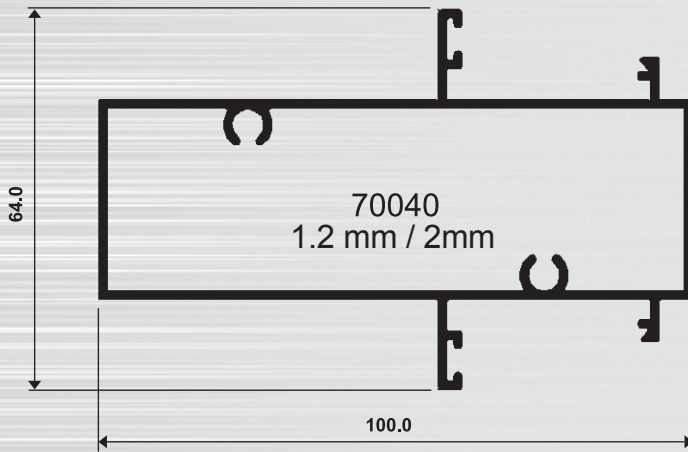

Deluxe Sliding Door/Window Sections 1.2mm

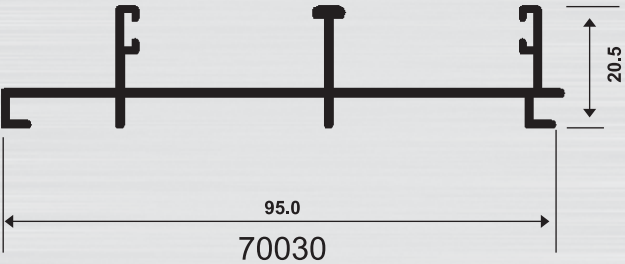
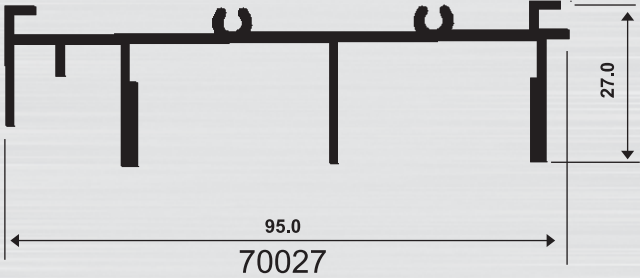
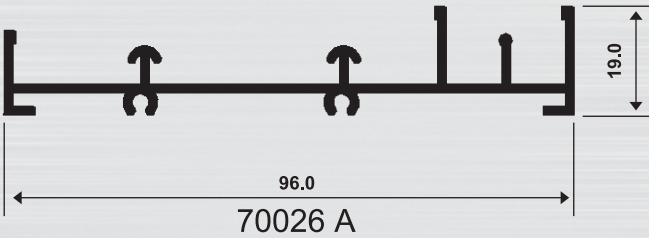
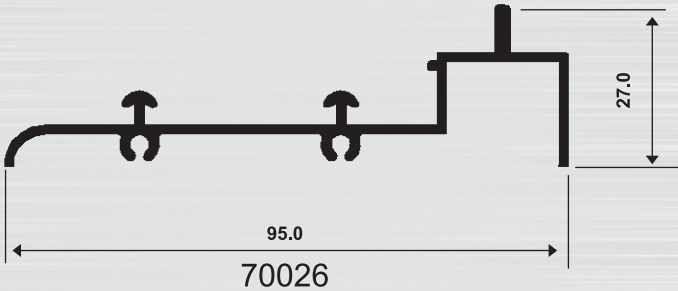

Deluxe Sliding Door/Window Sections 1.2mm

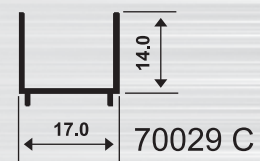
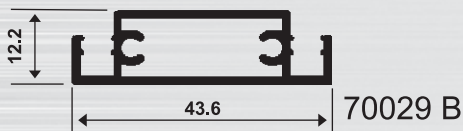
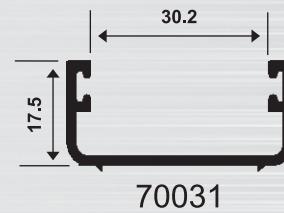
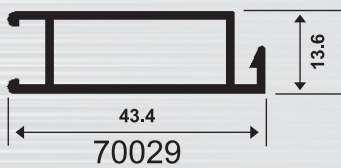
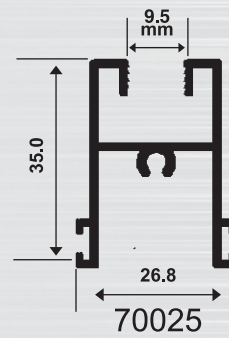
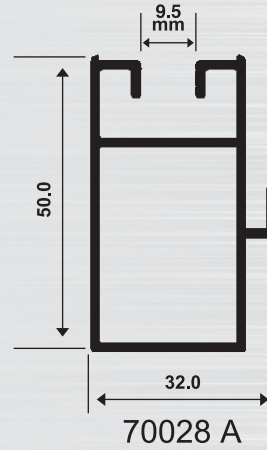
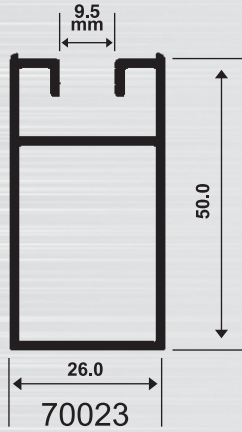

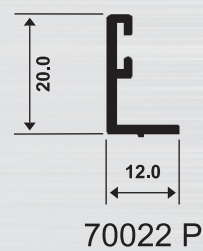
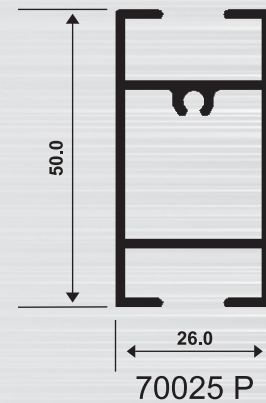
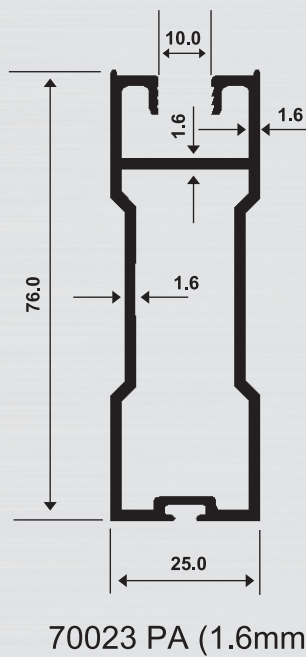
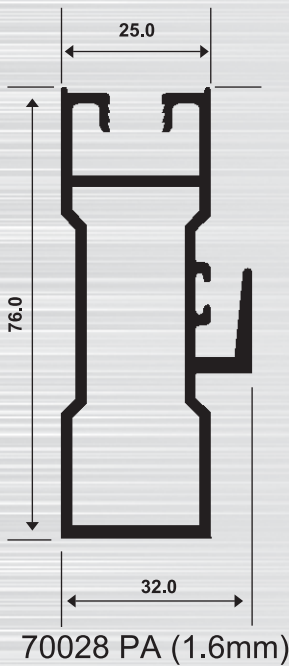
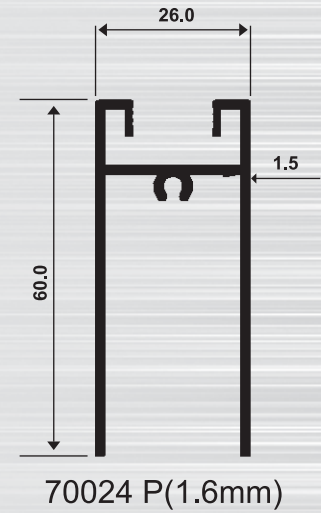
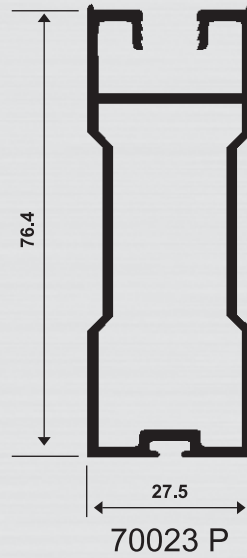
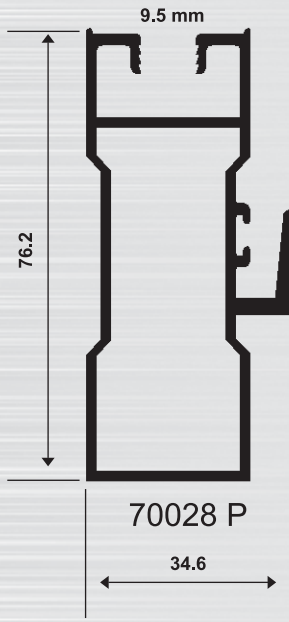

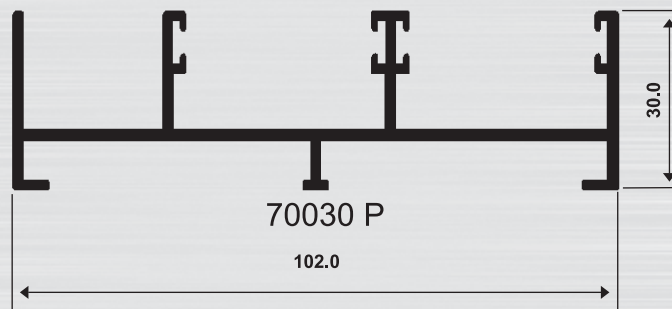
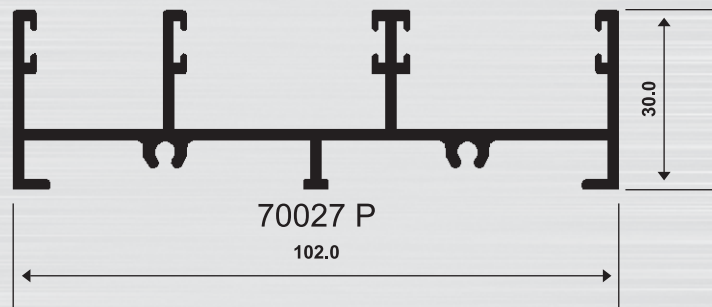
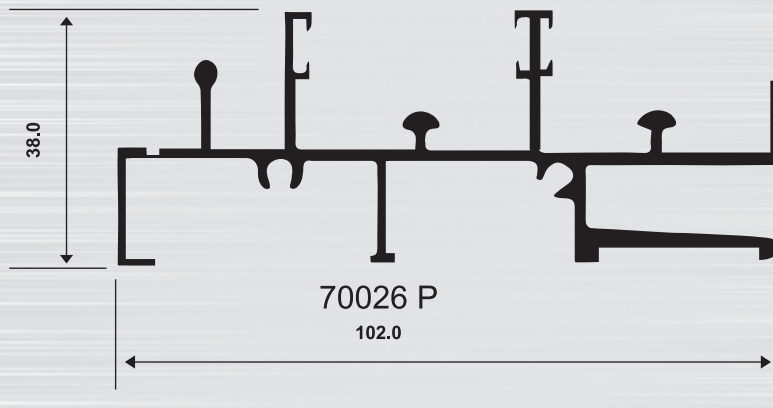

Semi Deluxe Sliding Door/Window Sections

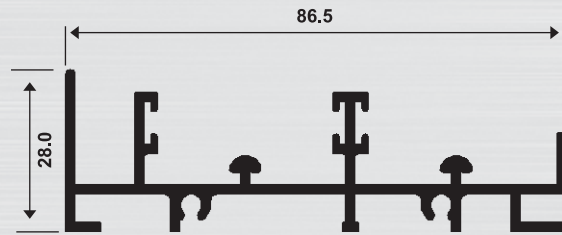

70026 B

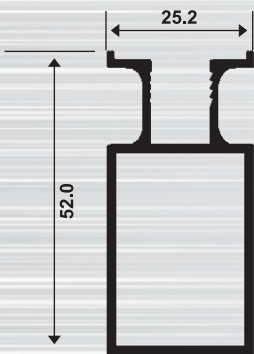

70023 B

1.2mm & 2mm

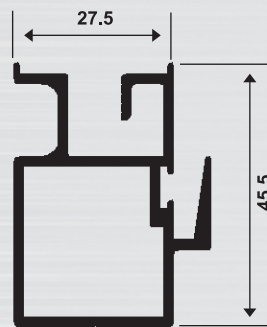

70028 B

1.2mm & 2mm

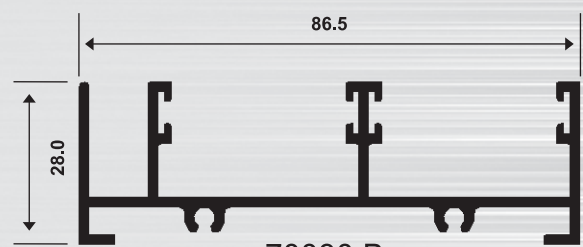

70030 B

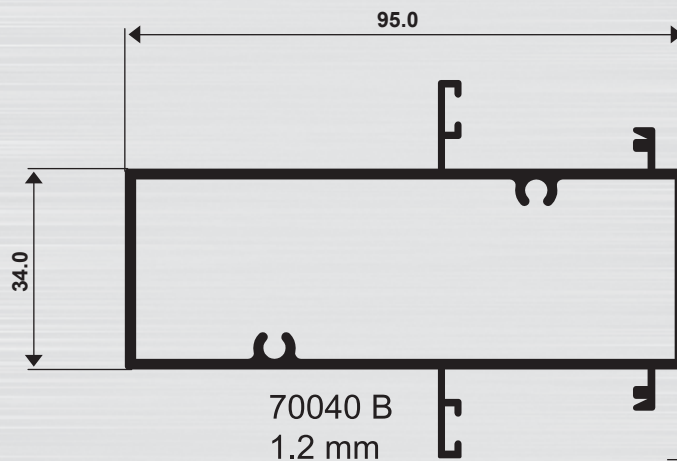

70040 B
1.2 mm

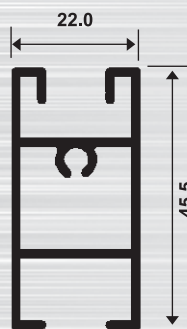

70025 M

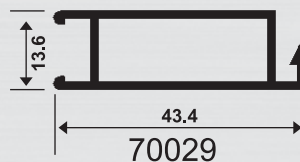

70029

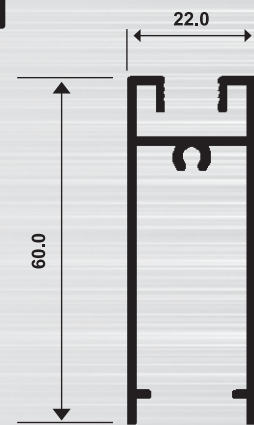

70024 M

Openable Door Section-5"

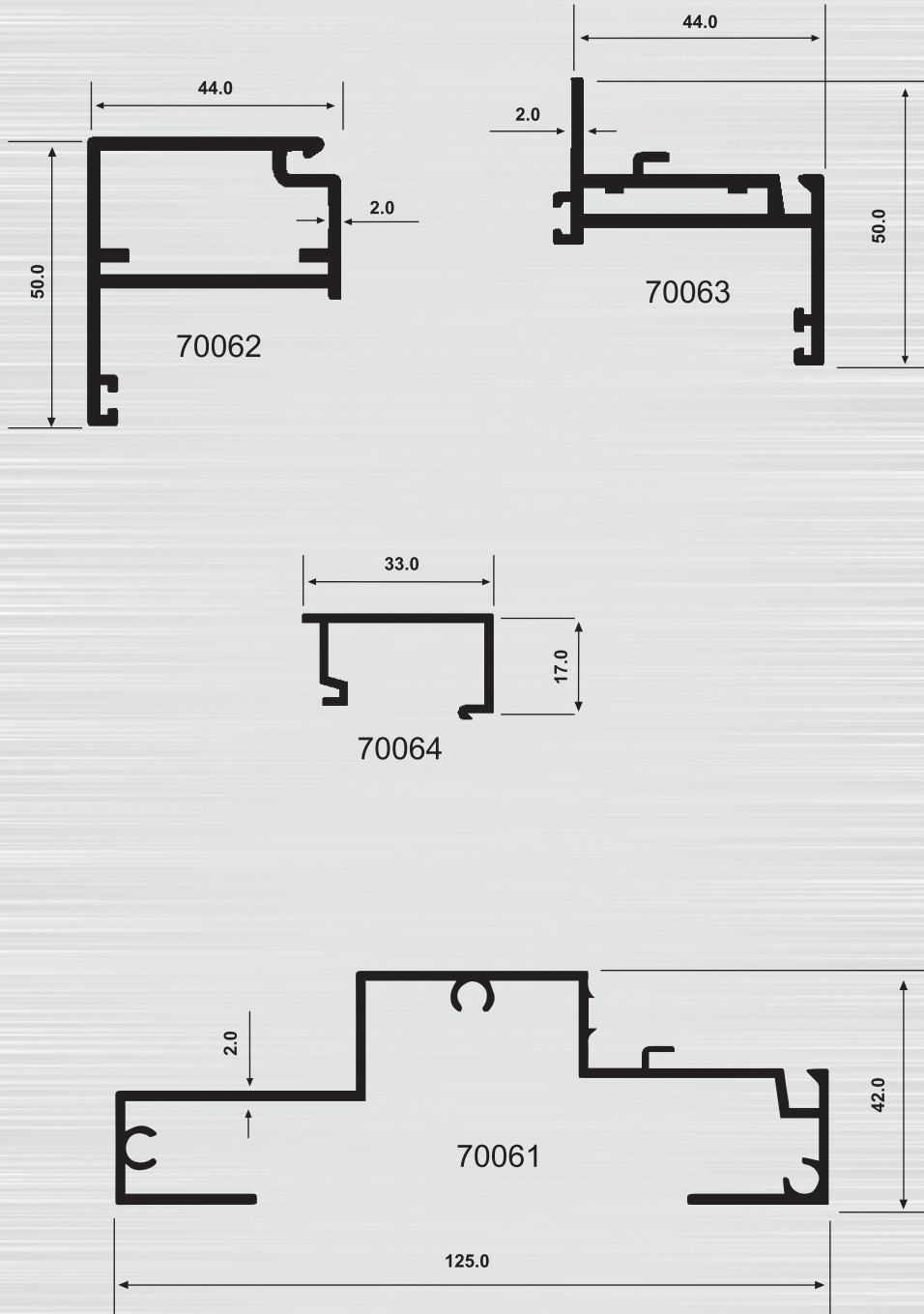

Hinged Door Section-4" 1.6mm

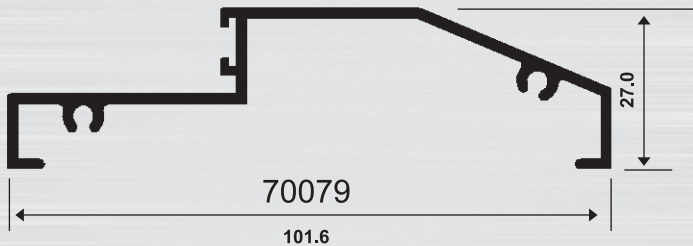
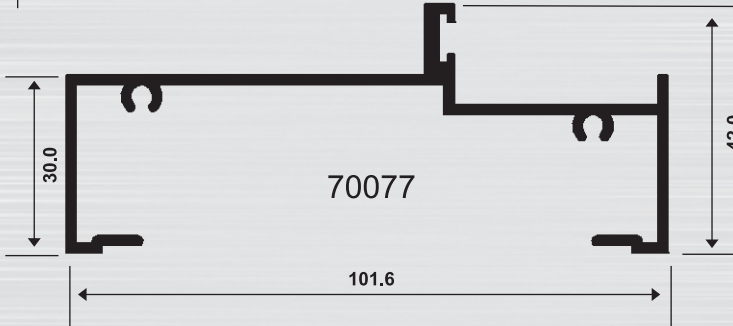
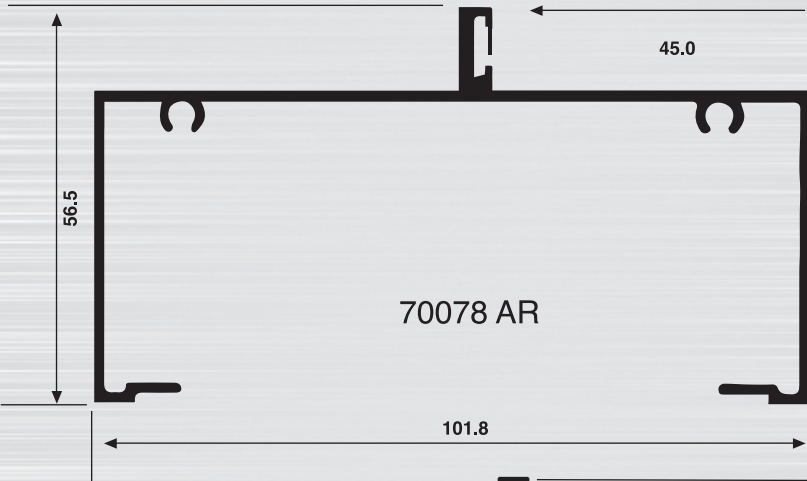
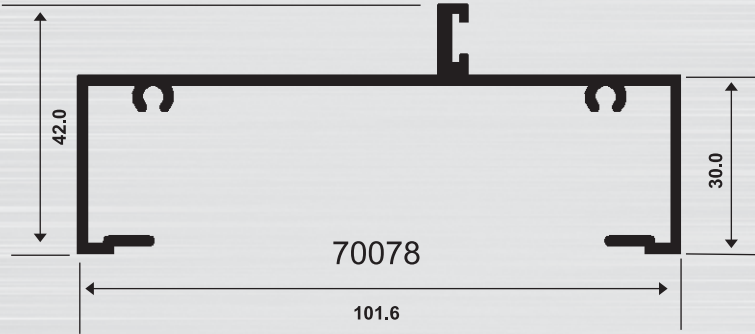

Hinged Door Section-3"

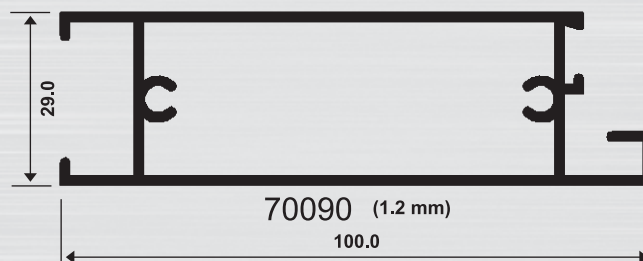
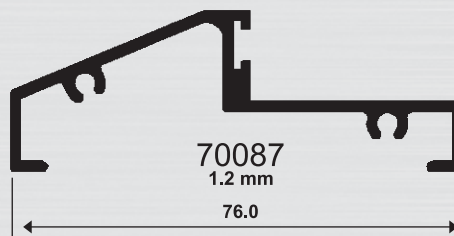
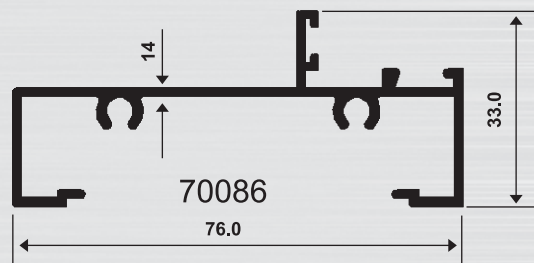
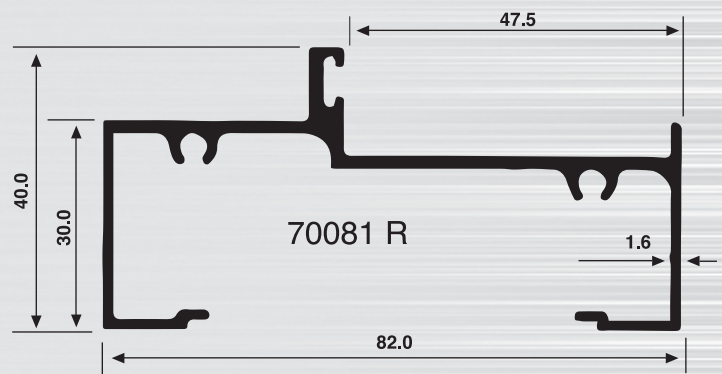
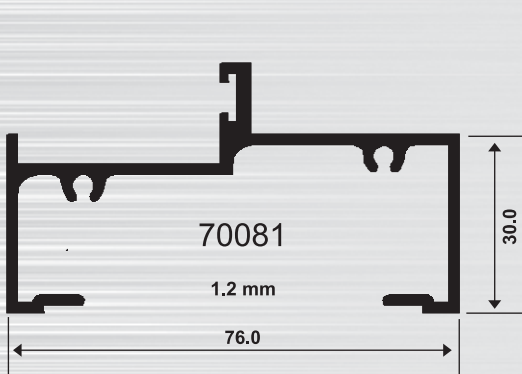
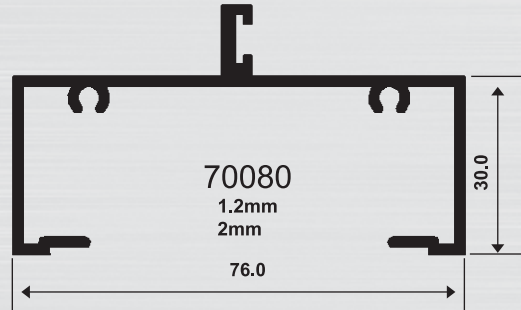

Hinged Door Section-3" Normal 1.2mm

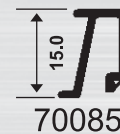
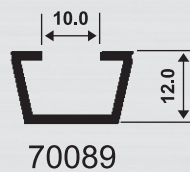
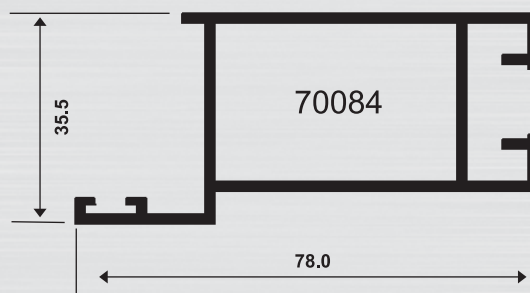
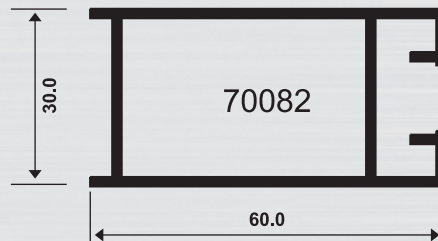
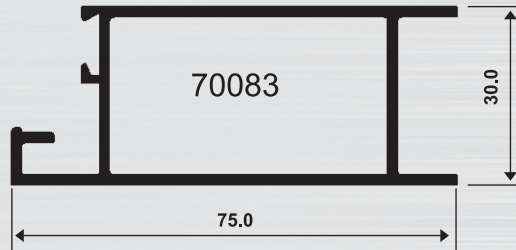

Curtain Wall Sections

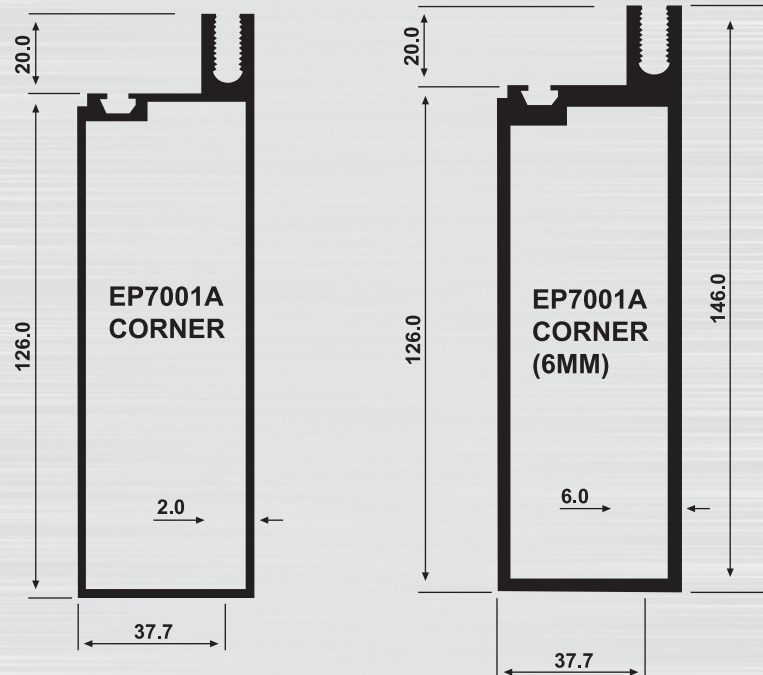
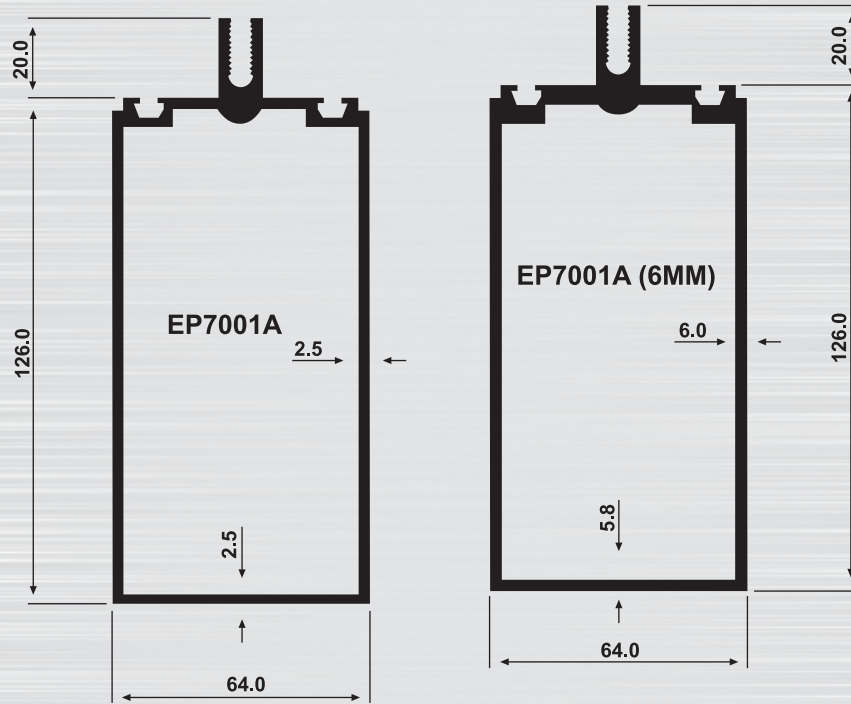

Curtain Wall Sections

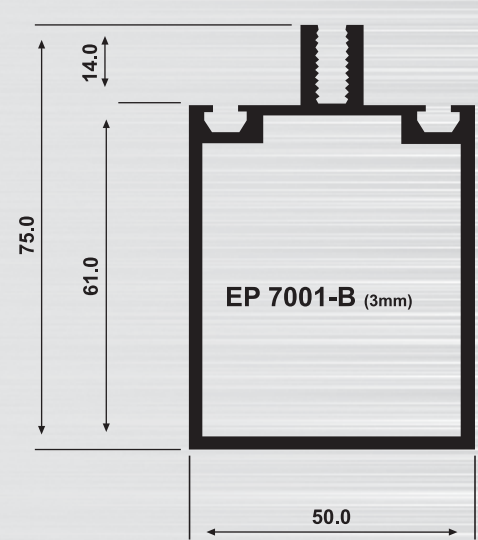
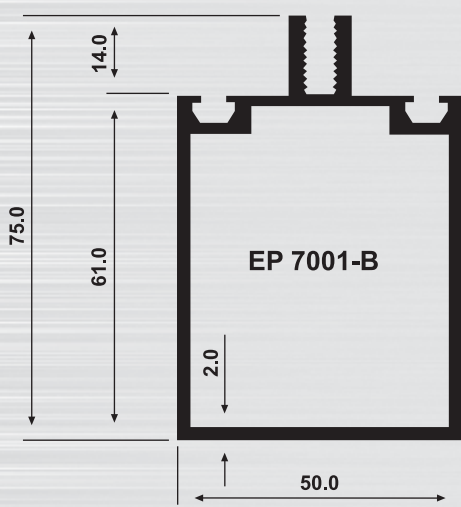
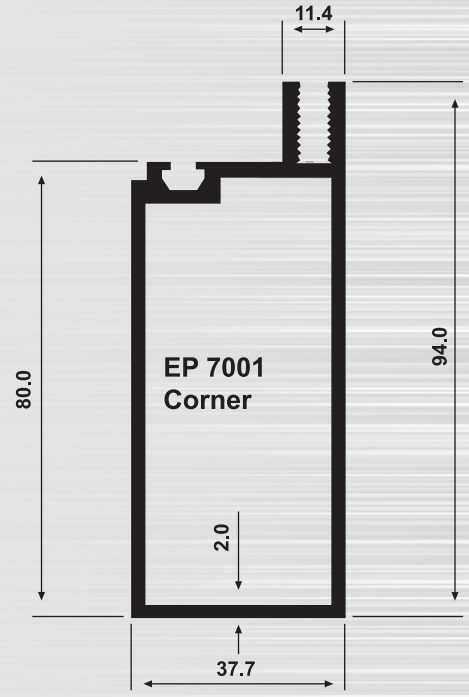
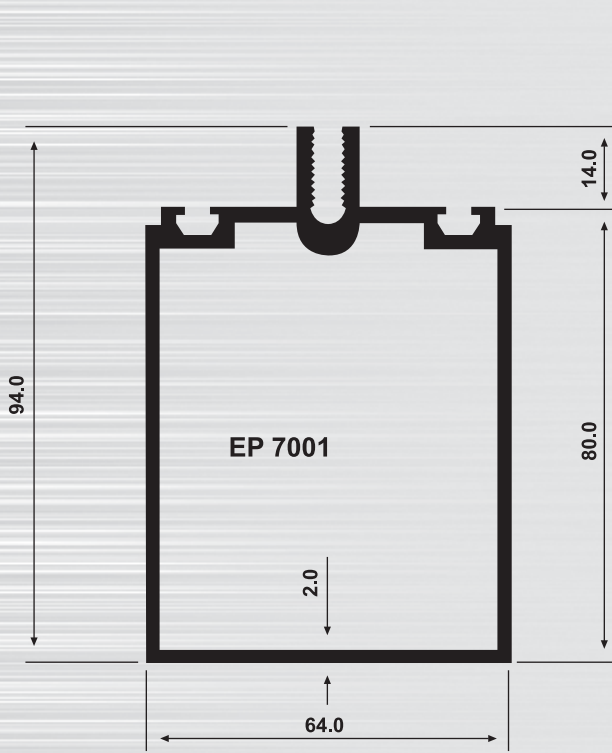

Curtain Wall Sections

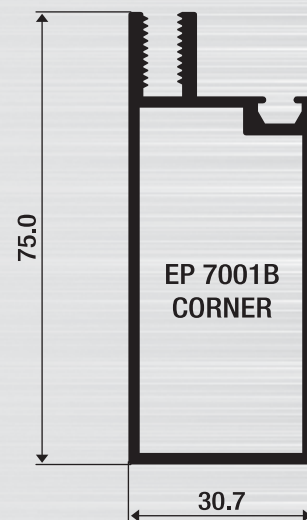
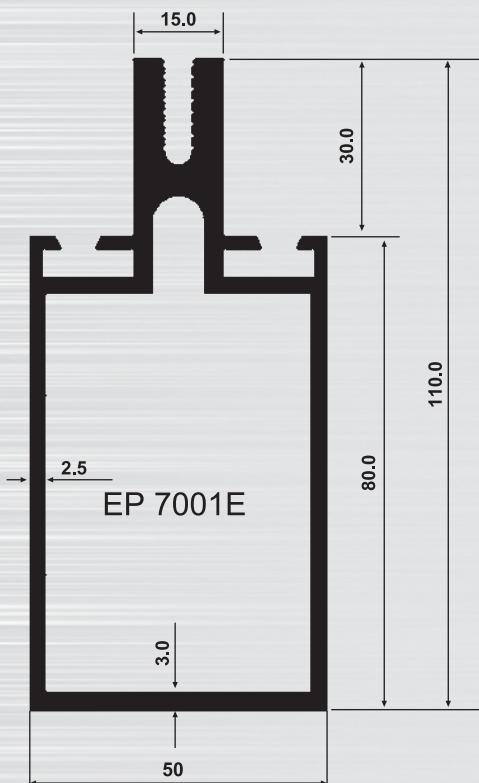
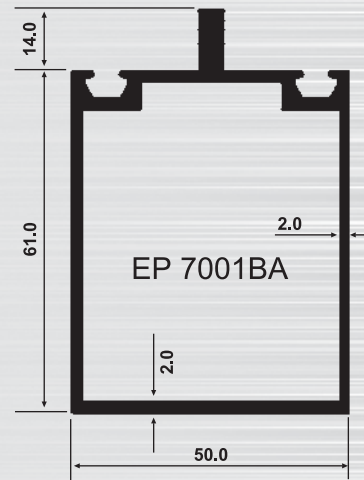
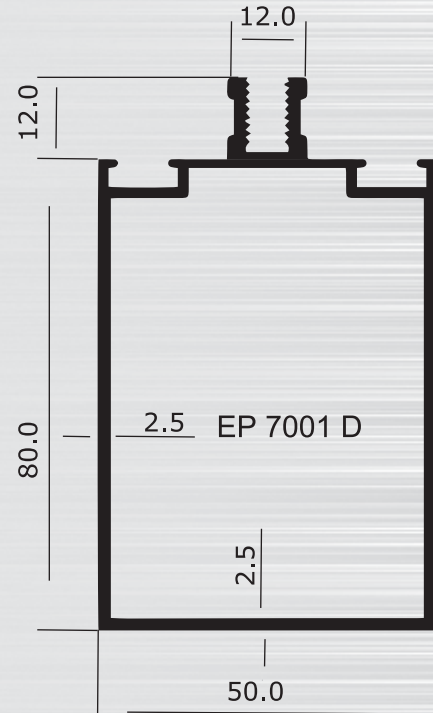

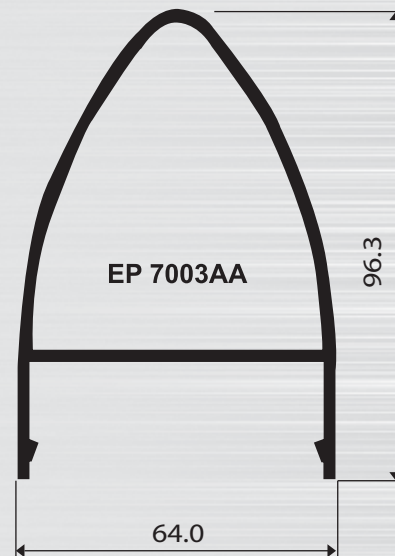
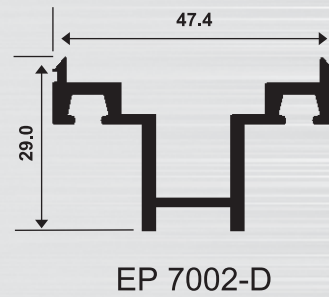
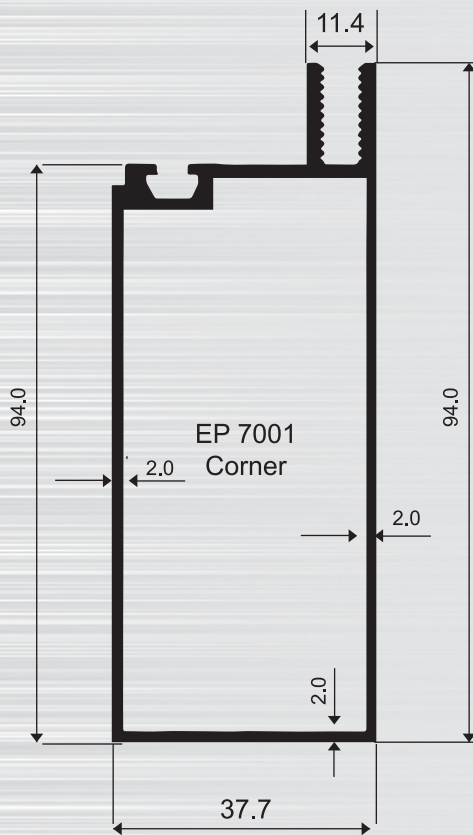
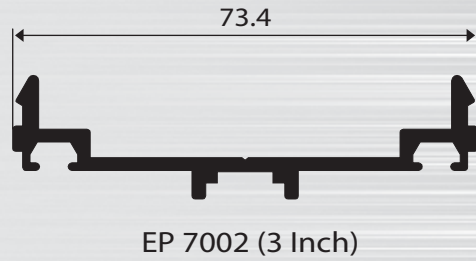
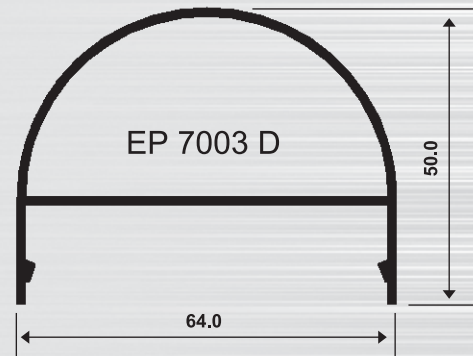

Curtain Wall Sections

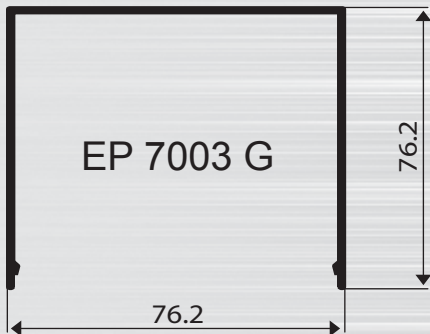
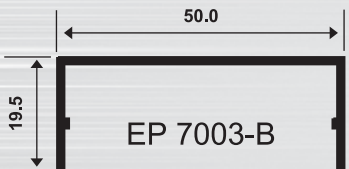
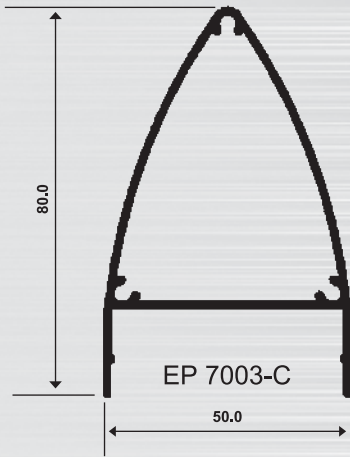
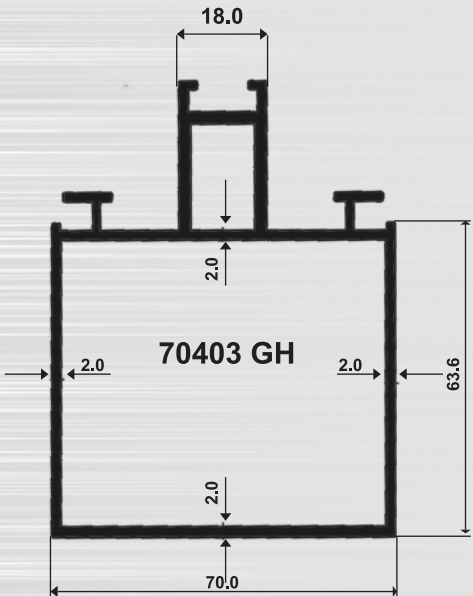
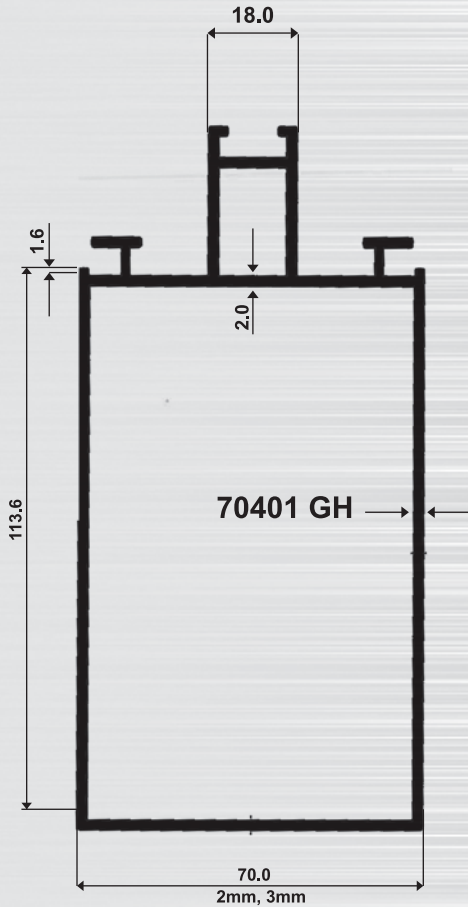
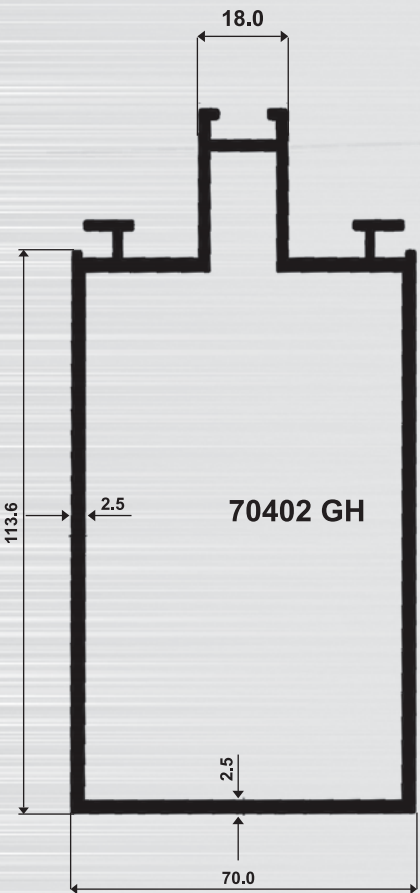

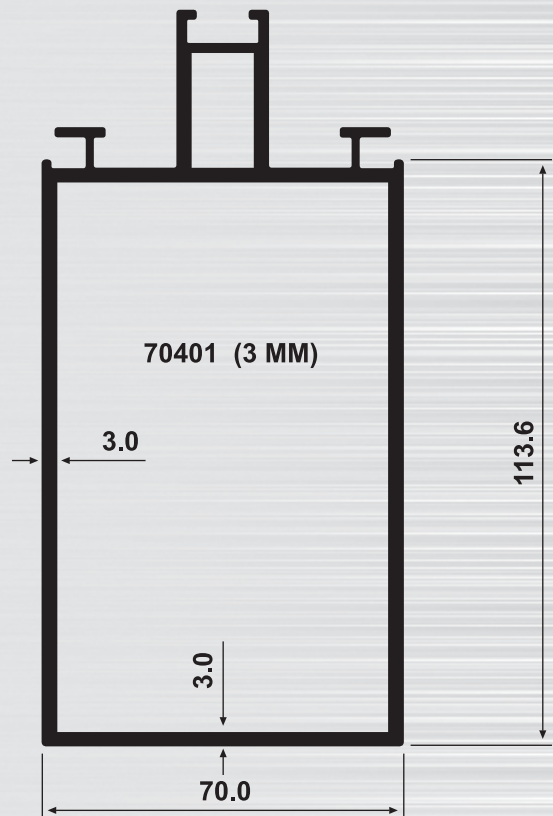
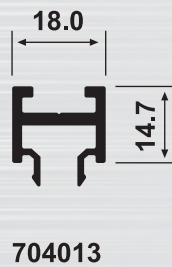
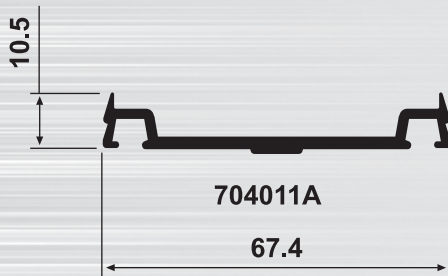
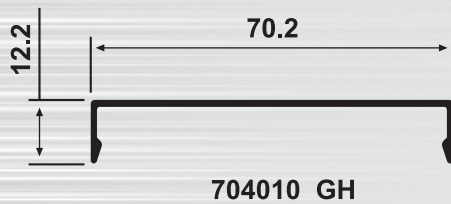
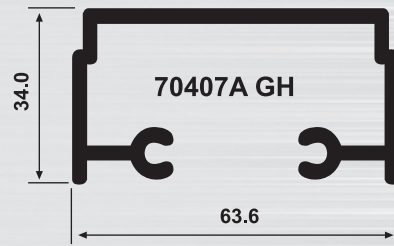
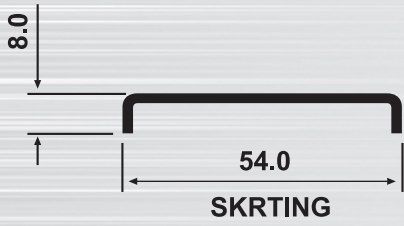

Curtain Wall Sections

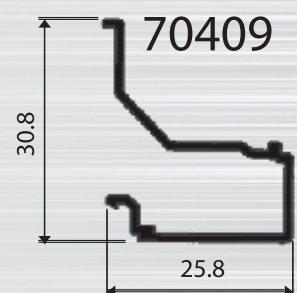
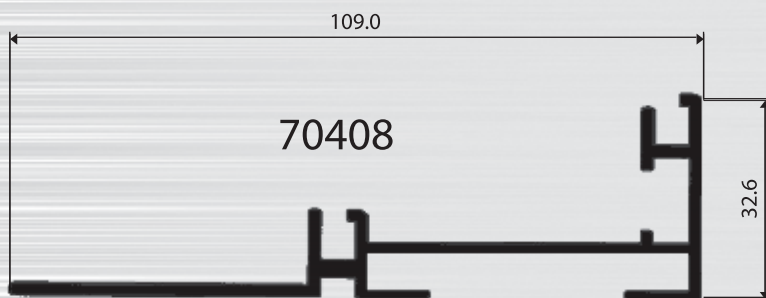
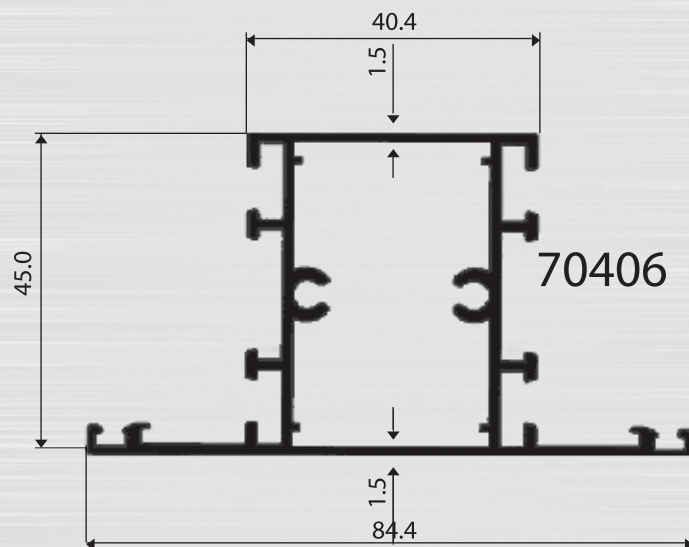
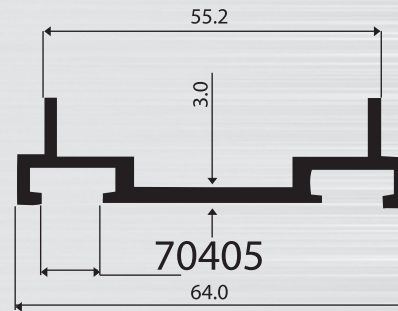
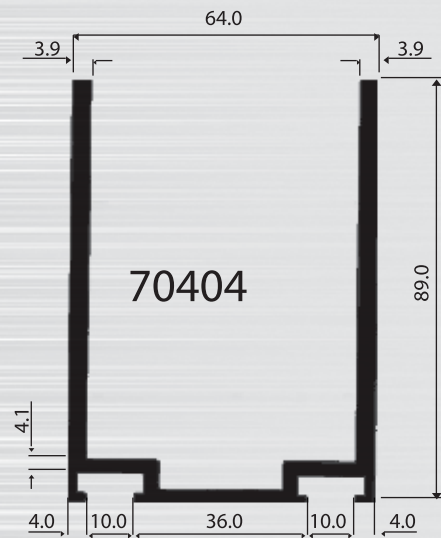

Curtain Wall Sections

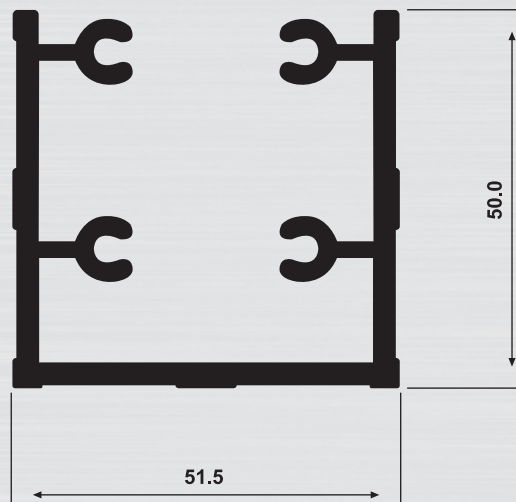
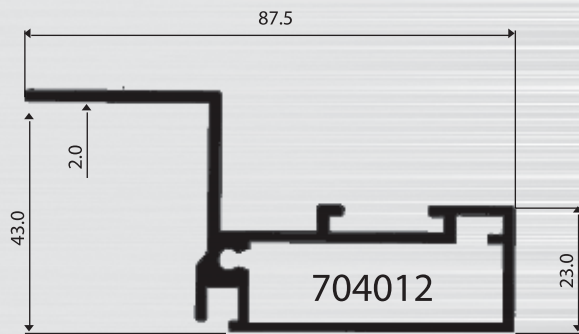
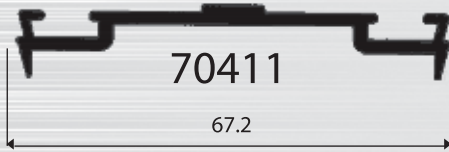
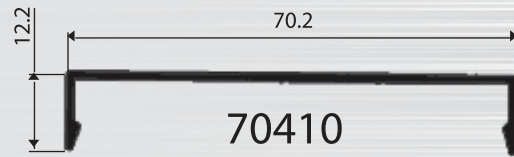
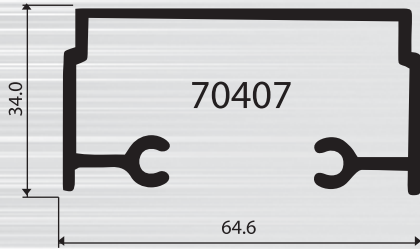

Curtain Wall Accessories

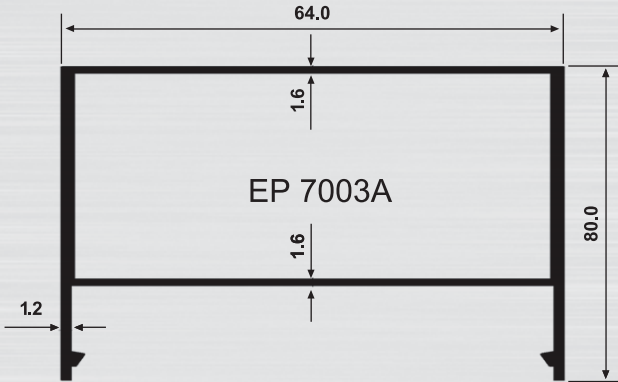
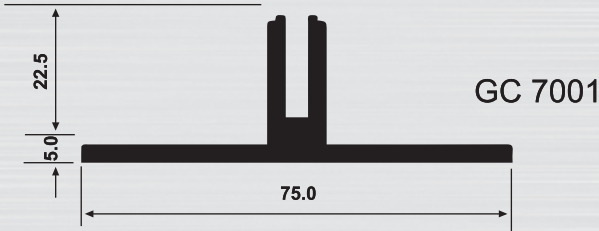
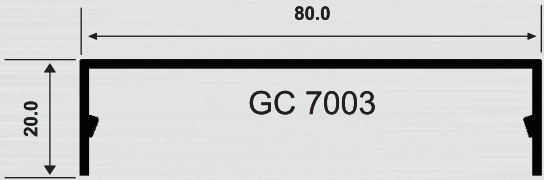

Curtain Wall Accessories

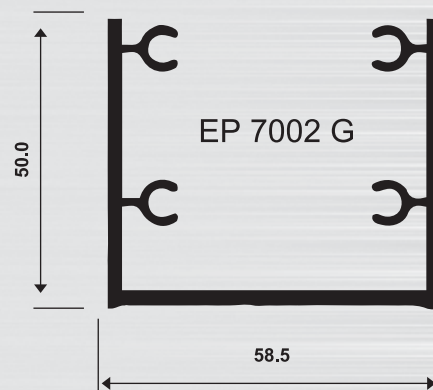
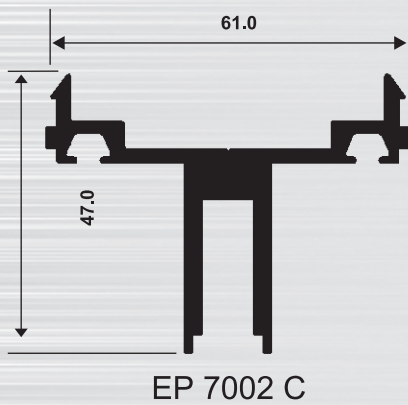
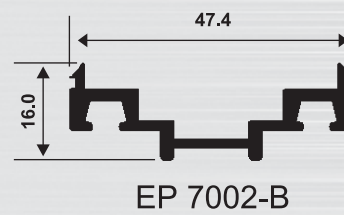
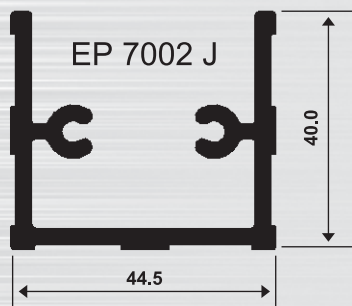
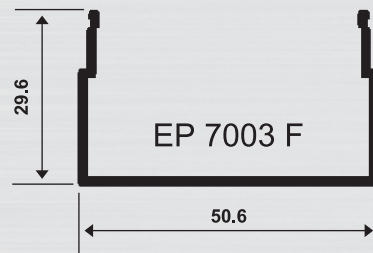

Dual Bonding Structural Glazing

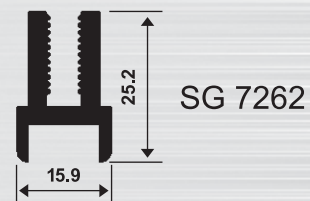
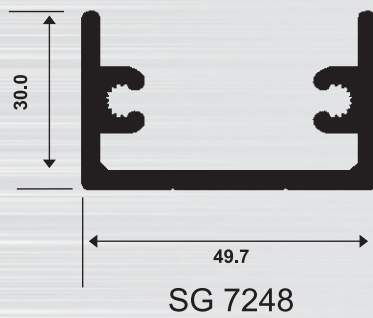
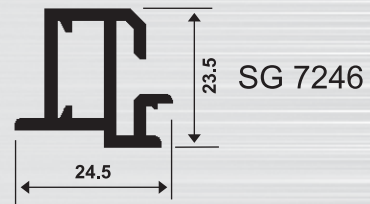
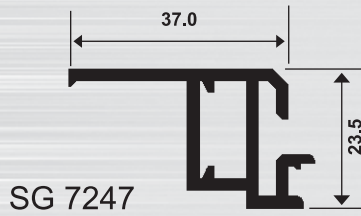
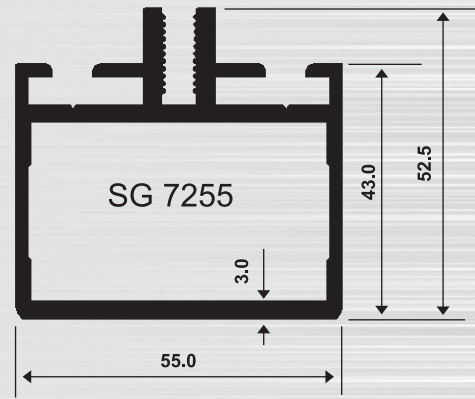

Facade Openable Window Sections

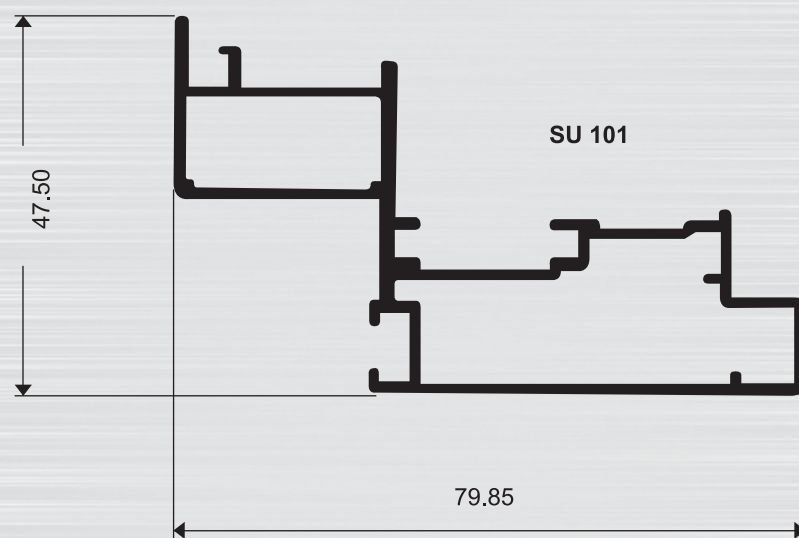
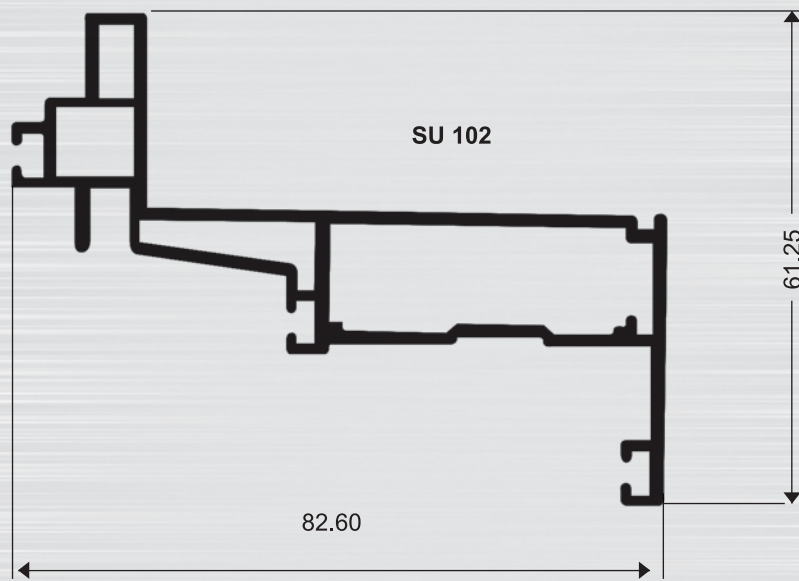

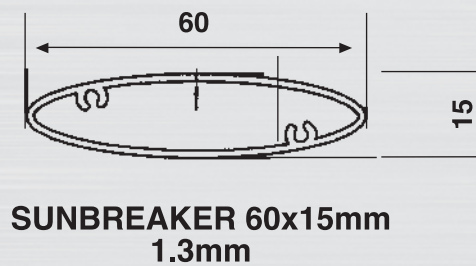
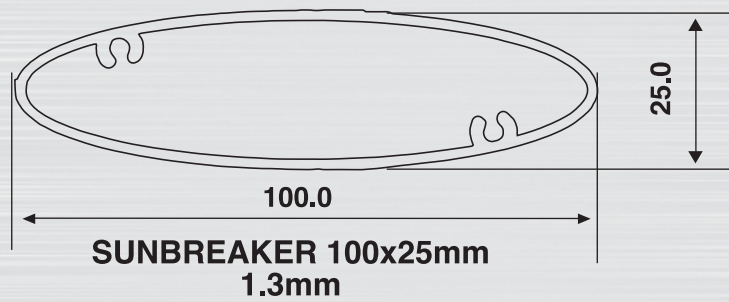
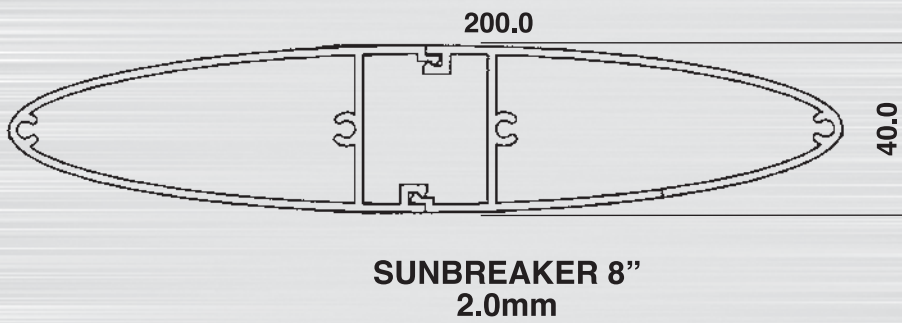
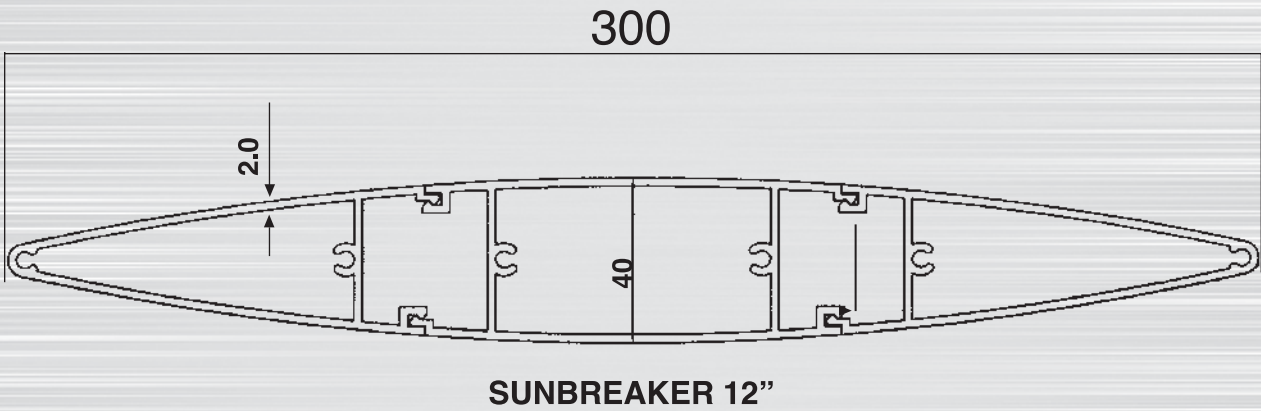

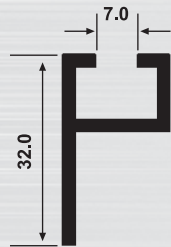

WINDOW STAY B

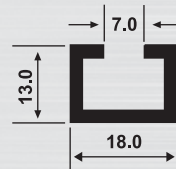

WINDOW STAY A

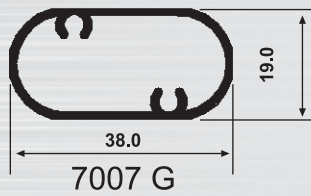

7007 G

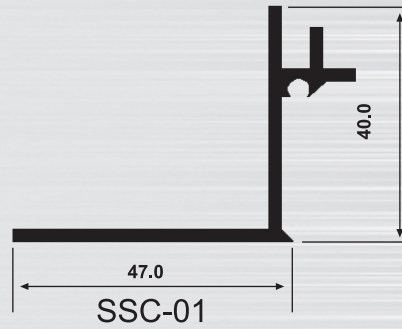

SSC-01

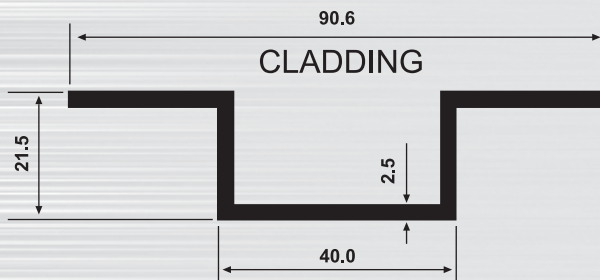

CLADDING

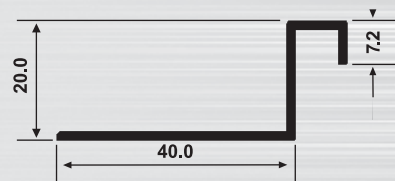

GLASS ANGLE

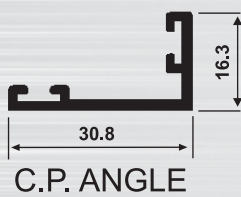

C.P. ANGLE

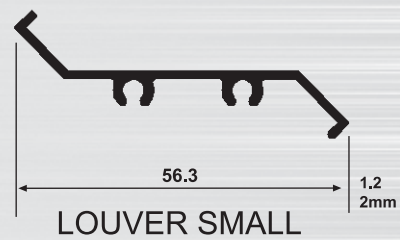

LOUVER SMALL

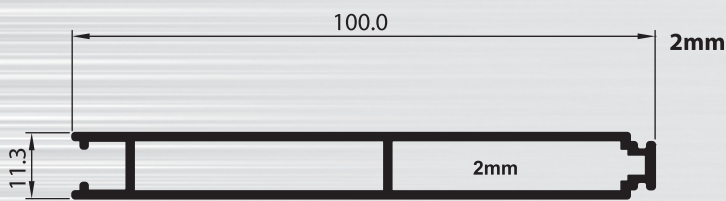
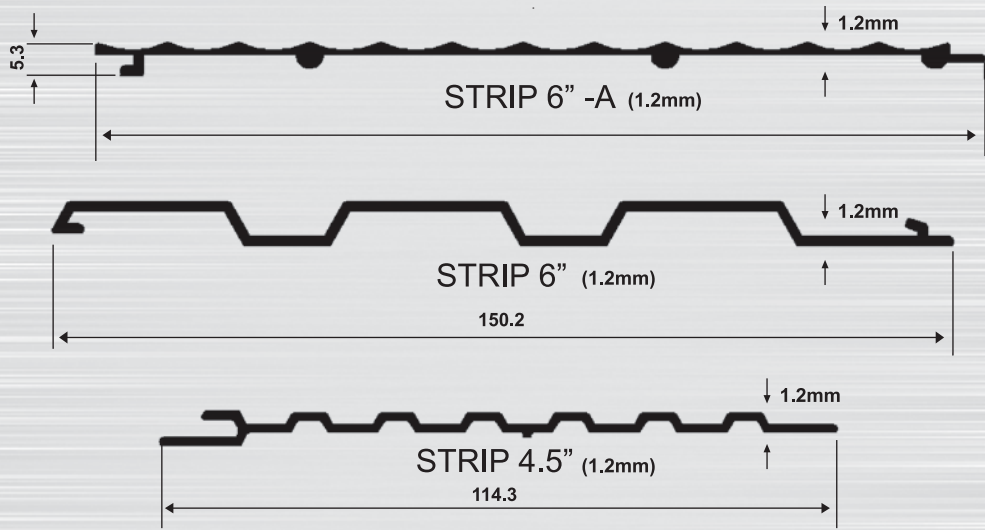

KICK PLATE

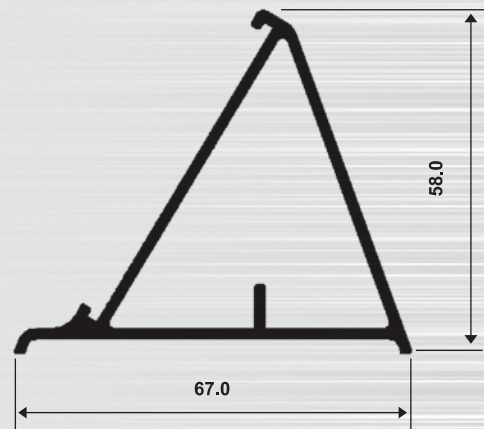
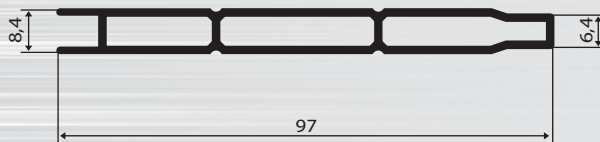
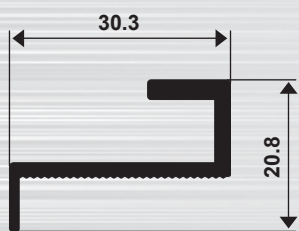

TABLE CALENDAR SECTION



KICK PLATE - B



HT 001

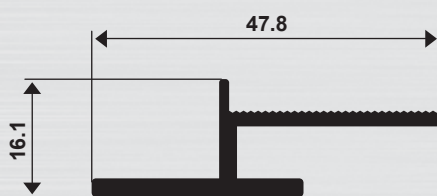

HT 002

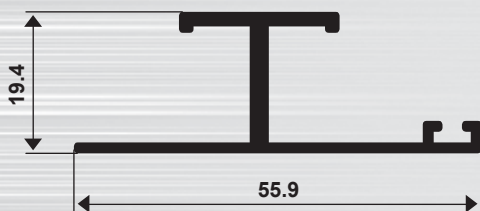

HT 003

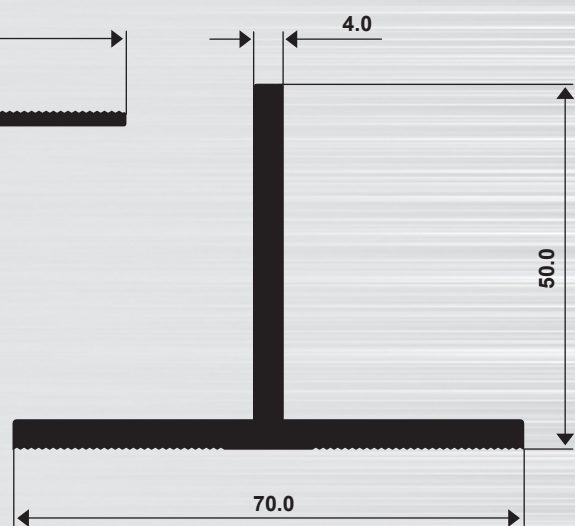

HT 004

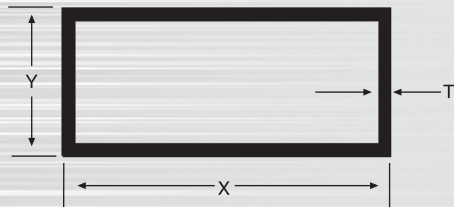

Rectangular Pipe

X	Y	T
2"	1"	1.5mm
3"	1"	1.5mm
3"	1.5"	1.5mm
4"	1.75"	1.5mm
4"	1.75"	2.0mm
45mm	45mm	2.0mm
1.5"	1.5"	1.5mm

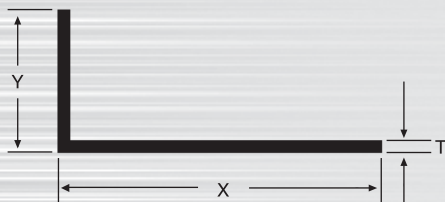

Angles

X	Y	T
19	19	1.5
19	19	3.0
19	14	3.0
25	25	1.0
25	25	2.0
25	25	3.0
30	30	2.5
32	32	1.8
40	15	3
38	38	3
40	40	4
40	40	6
50	75	4
56	76	6
38	38	5mm

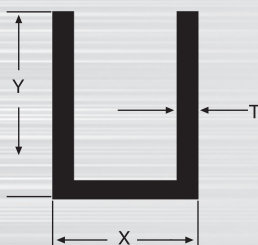

U-Channel. 1X3/4"

X	Y	T
57	60	3.5
25	28	2
19	35	2
38	19	2
10	10	3

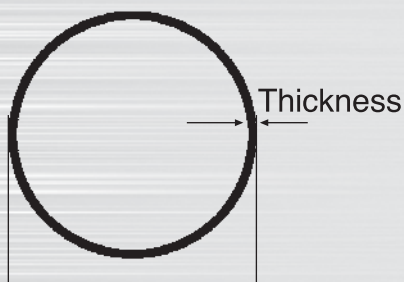

Round Pipe

Outer Dia MM	Inner Dia MM	Thickness MM
40	36	2
32	28	2
44.5	40.5	2
25	19	3

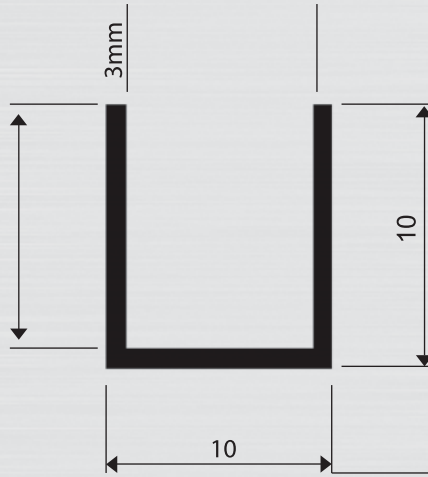

U - Chanal 10 x 10 x 3 mm

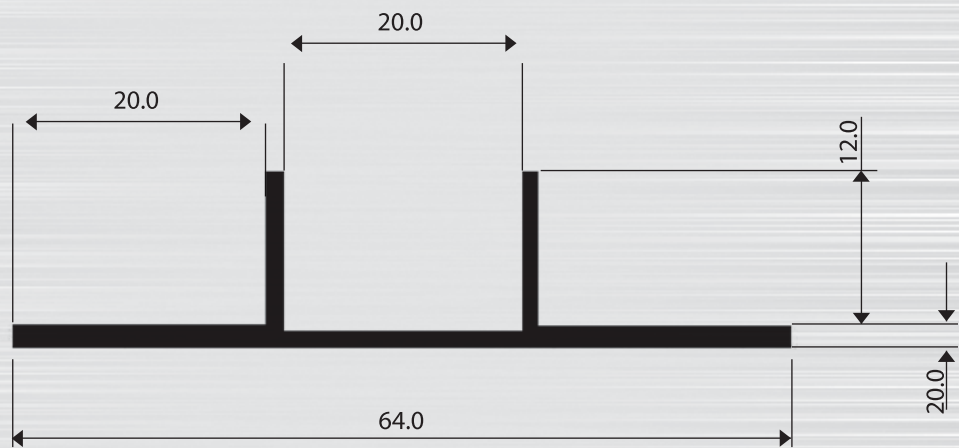

4 Bracket

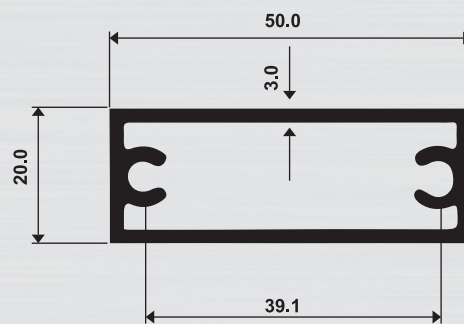

Stiffener

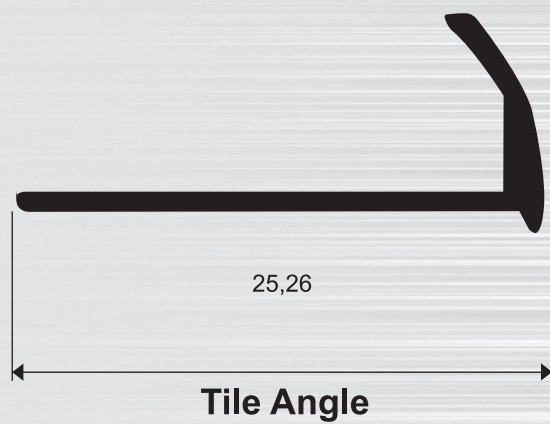
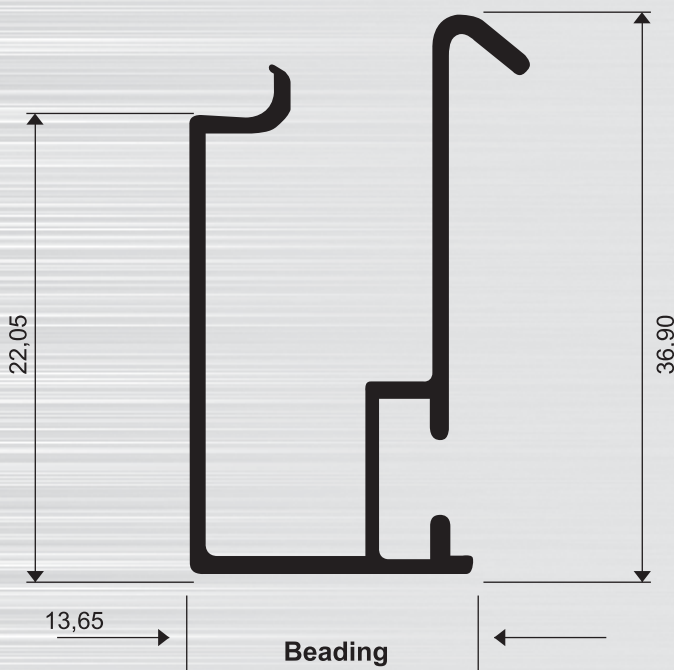
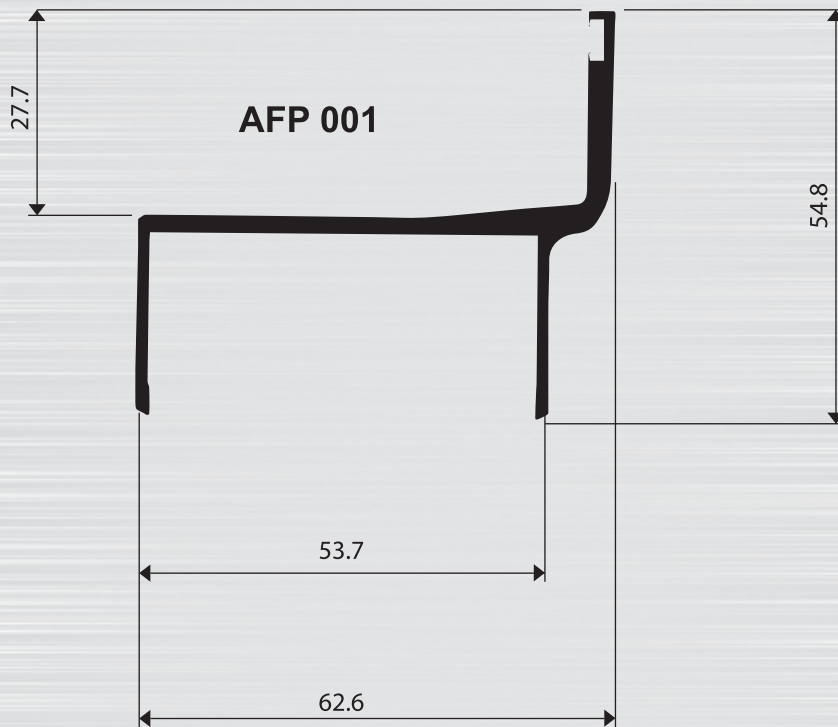

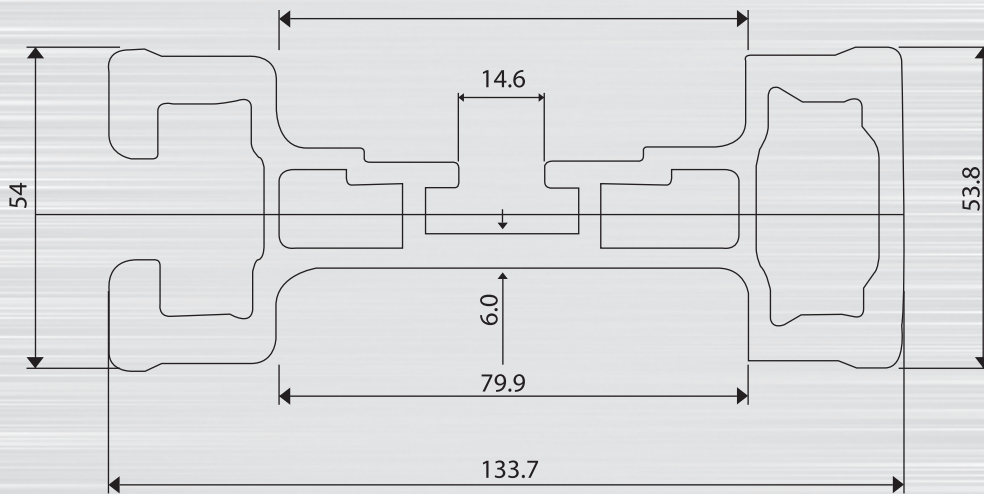
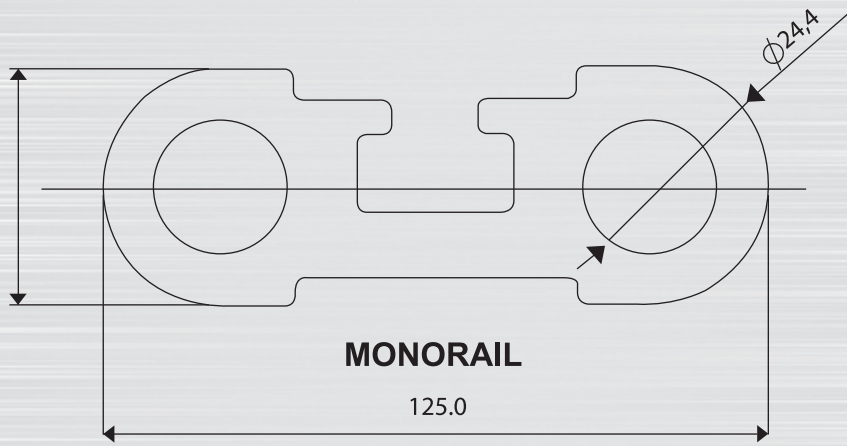

MONORAIL - A

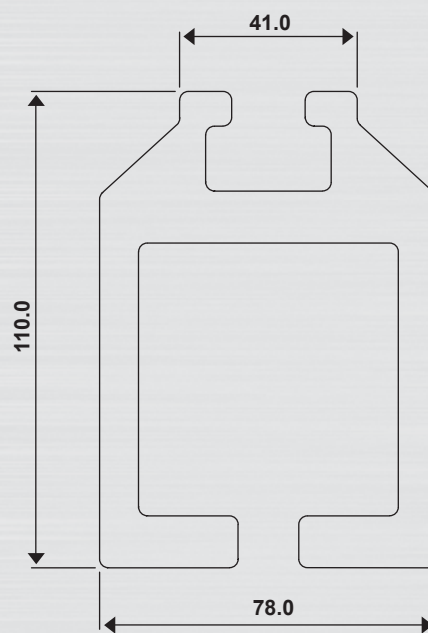

MONORAIL - B

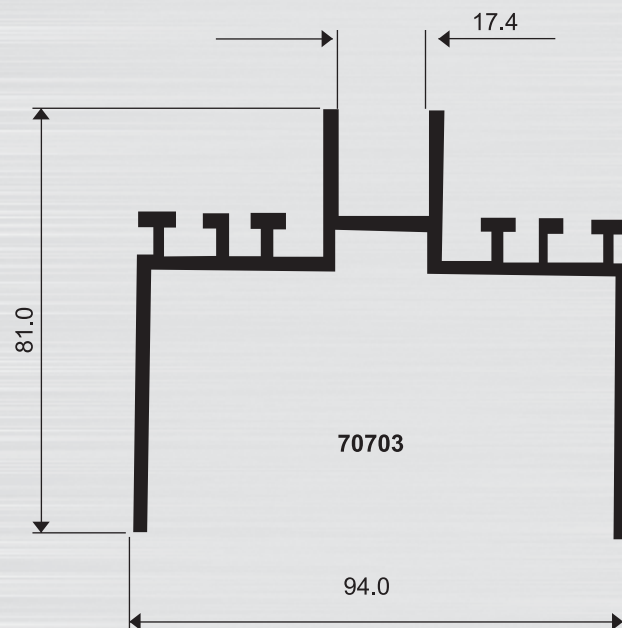
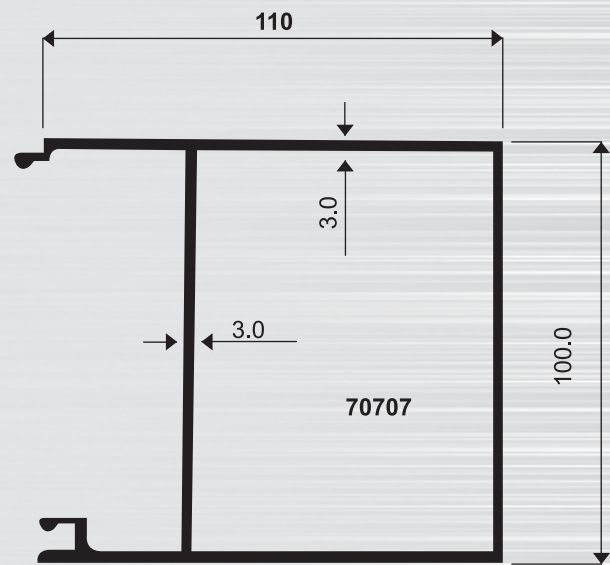
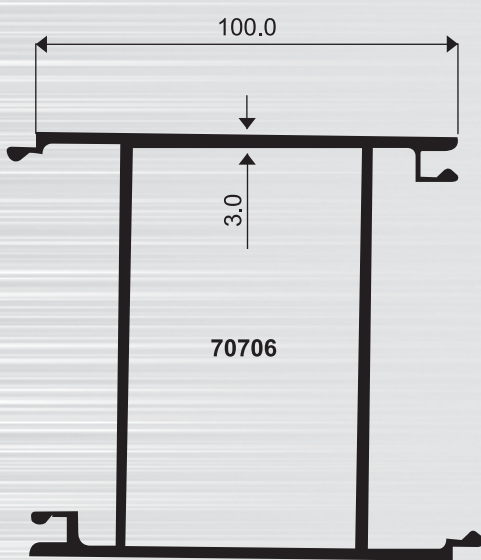

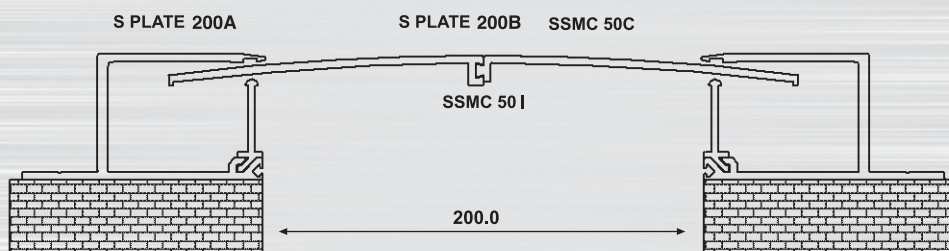
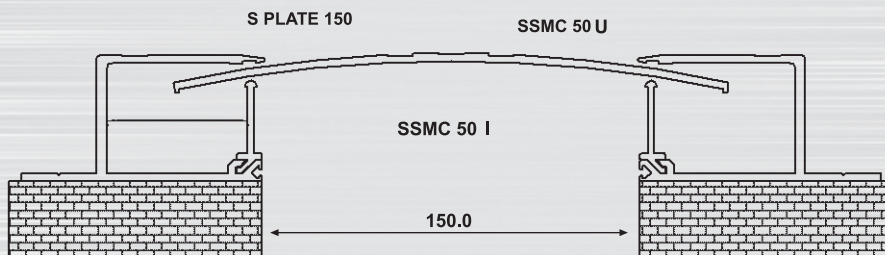
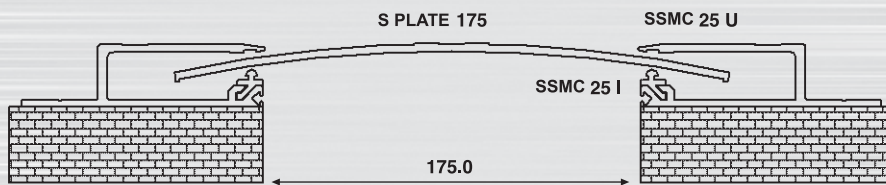
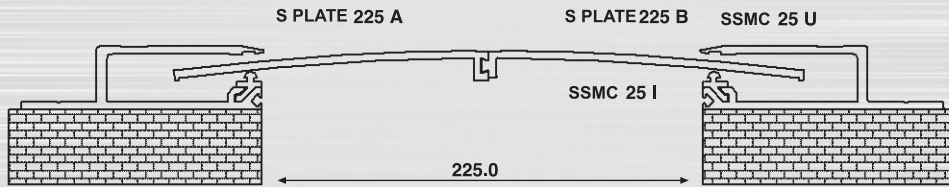

Seismic Expansion Joints

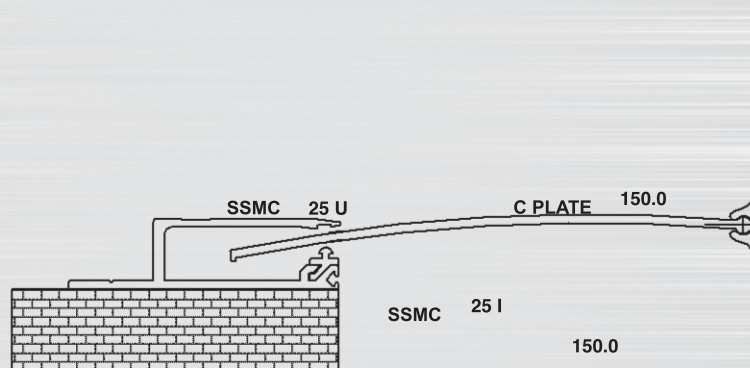
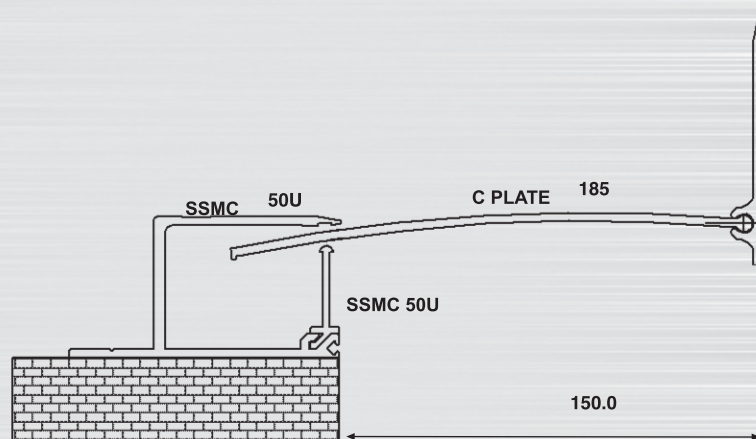
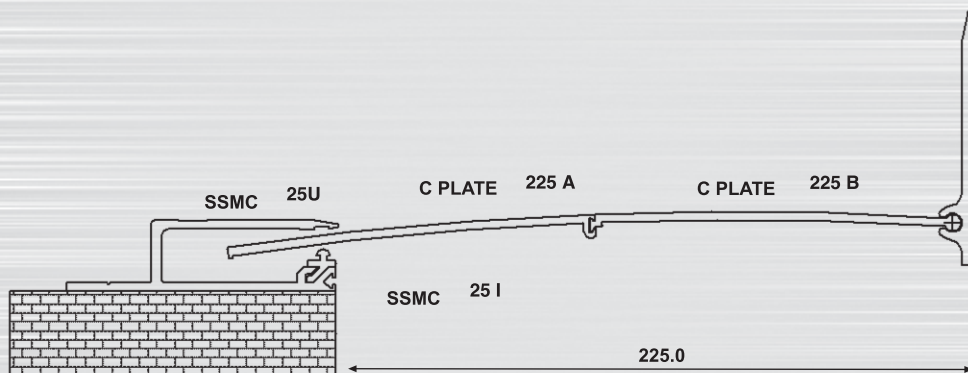
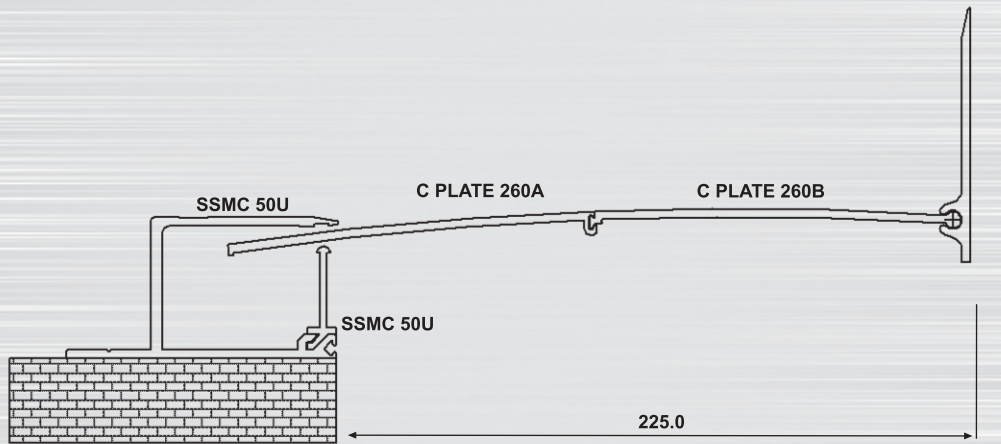

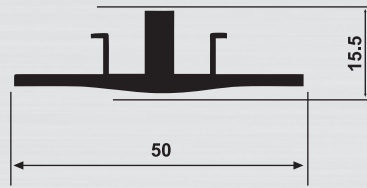

Central Bridge Plate Angle

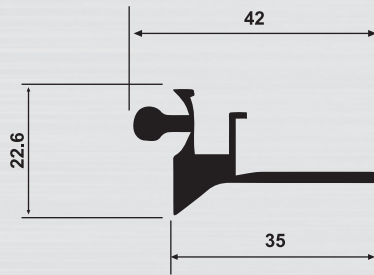

Side Bridge Plate Angle

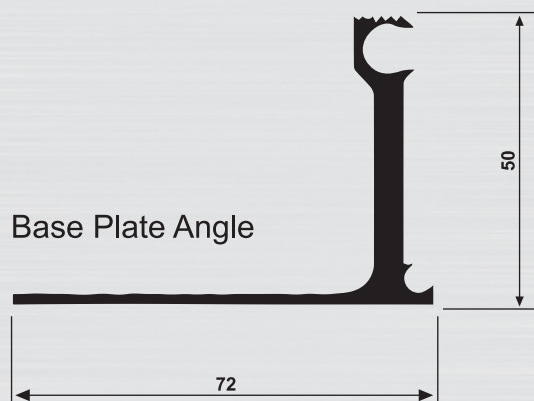

Base Plate Angle



Pakistan Cables Limited, Arif Habib Center, 1st Floor, 23 M. T. Khan Road, Karachi.
UAN: (021)111-CABLES (222-537) Ext: 818, Direct: (+92-21)32462110, Fax: (+92-21) 32462111
www.pakistancables.com